

HOLT CALIFORNIA 
**Physical
Science**

**Interactive Reader
and Study Guide**



HOLT, RINEHART AND WINSTON

A Harcourt Education Company

Orlando • Austin • New York • San Diego • London

Copyright © by Holt, Rinehart and Winston

All rights reserved. No part of this publication may be reproduced or transmitted in any form or by any means, electronic or mechanical, including photocopy, recording, or any information storage and retrieval system, without permission in writing from the publisher.

Requests for permission to make copies of any part of the work should be mailed to the following address: Permissions Department, Holt, Rinehart and Winston, 10801 N. MoPac Expressway, Building 3, Austin, Texas 78759.

HOLT and the “**Owl Design**” are trademarks licensed to Holt, Rinehart and Winston, registered in the United States of America and/or other jurisdictions.

Printed in the United States of America

If you have received these materials as examination copies free of charge, Holt, Rinehart and Winston retains title to the materials and they may not be resold. Resale of examination copies is strictly prohibited and is illegal.

Possession of this publication in print format does not entitle users to convert this publication, or any portion of it, into electronic format.

ISBN 0-03-092479-0

1 2 3 4 5 6 7 082 10 09 08 07 06

Contents

CHAPTER 1 The Nature of Physical Science

SECTION 1 Science and Scientists	1
SECTION 2 Scientific Methods	7
SECTION 3 Safety in Science	15

CHAPTER 2 Data in Science

SECTION 1 Tools and Models in Science	20
SECTION 2 Organizing Your Data	28
SECTION 3 Analyzing Your Data	34

CHAPTER 3 Properties of Matter

SECTION 1 What Is Matter?	40
SECTION 2 Physical Properties	46
SECTION 3 Chemical Properties	52

CHAPTER 4 States of Matter

SECTION 1 Four States of Matter	57
SECTION 2 Changes of State	61

CHAPTER 5 Elements, Compounds, and Mixtures

SECTION 1 Elements	67
SECTION 2 Compounds	71
SECTION 3 Mixtures	75

CHAPTER 6 Introduction to Atoms

- SECTION 1** Development of the Atomic Theory. **81**
SECTION 2 The Atom. **89**

CHAPTER 7 The Periodic Table

- SECTION 1** Arranging the Elements. **97**
SECTION 2 Grouping the Elements. **105**

CHAPTER 8 Chemical Bonding

- SECTION 1** Electrons and Chemical Bonding. **113**
SECTION 2 Ionic Bonds **117**
SECTION 3 Covalent and Metallic Bonds **123**

CHAPTER 9 Chemical Reactions

- SECTION 1** Forming New Substances. **129**
SECTION 2 Chemical Formulas and Equations. **134**

CHAPTER 10 Chemical Compounds

- SECTION 1** Ionic and Covalent Compounds. **139**
SECTION 2 Acids and Bases **144**
SECTION 3 Solutions of Acids and Bases **149**

CHAPTER 11 The Chemistry of Living Things

- SECTION 1** Elements in Living Things **153**
SECTION 2 Compounds of Living Things **157**

CHAPTER 12 Matter in Motion

SECTION 1 Measuring Motion	163
SECTION 2 What Is a Force?	169
SECTION 3 Friction: A Force That Opposes Motion	174

CHAPTER 13 Forces and Motion

SECTION 1 Gravity: A Force of Attraction	178
SECTION 2 Gravity and Motion	183
SECTION 3 Newton’s Laws of Motion.	191

CHAPTER 14 Forces in Fluids

SECTION 1 Fluids and Pressure.	199
SECTION 2 Buoyancy and Density	205

CHAPTER 15 Stars, Galaxies, and the Universe

SECTION 1 Stars	213
SECTION 2 The Life Cycle of Stars	219
SECTION 3 Galaxies	224
SECTION 4 Formation of the Universe	228

CHAPTER 16 Our Solar System

SECTION 1 A Solar System is Born	232
SECTION 2 The Inner Planets	240
SECTION 3 The Outer Planets	246
SECTION 4 Moons	252
SECTION 5 Small Bodies in the Solar System	260

CHAPTER 1 The Nature of Physical Science

SECTION

1

Science and Scientists

BEFORE YOU READ

After you read this section, you should be able to answer these questions:

- What are three methods used by scientists to conduct investigations?
- How does science help people?
- What are five jobs available to people who want to be scientists?



California Science Standards

8.9.a

What Is Science?

Science is knowledge of the natural world. You gain this knowledge by observing and investigating the world around you. Science helps you discover facts and predict how things in the world will behave.

QUESTIONS

Asking a question is the first step in the process of gaining knowledge. The student pictured below is curious. She has thought up three questions about the world. ✓



Part of science is asking questions about the world around you.

You may have questions about different environments, such as deserts or the sea. You may wonder about the moon, the sun, and the whole universe. You may wonder how the food you eat keeps you healthy. These are all science questions.

STUDY TIP

Summarize As you read, keep a list of the different traits of good scientists. When you finish reading, write a paragraph telling why each trait is a good one for a scientist to have.

READING CHECK

1. Identify What is the first step in the process of gaining knowledge?

Critical Thinking

2. Describe What are two things the girl in the figure can do to answer her questions?

SECTION 1 Science and Scientists *continued*

CALIFORNIA STANDARDS CHECK

8.9.a Plan and conduct a scientific investigation to test a hypothesis.

Word Help: conduct to carry out

3. Explain What are three methods scientists use to answer questions?

How Do Scientists Search for Answers?

Scientists conduct careful investigations to find answers to questions about the natural world. As a scientist, you can use several methods to begin an investigation.

RESEARCH

You can look up information in books, in scientific journals, and on the Internet. You can also ask experts. It is important to think about the value of the information you get from the Web page you check or the person you ask. Are they information sources you can trust?

OBSERVATION

You can find answers to some questions on your own, by observing what is going on around you. *Observing* means using your senses to study what is happening. For example, you may notice that before a storm, there are big, dark clouds in the sky. You also may notice that the wind is blowing from the west. These observations could lead you to research whether these two things are related.

EXPERIMENTATION

You can answer some of your questions by doing experiments. An *experiment* is a test of an idea. Before experimenting, you must come up with a prediction or a likely answer to your question. For example, you could suggest that the wind blows big, dark clouds from the west. Your prediction could be that storms come from the west. Then, you could make a plan to test your prediction.

Critical Thinking

4. Explain How could you test your explanation that storms come from the west?

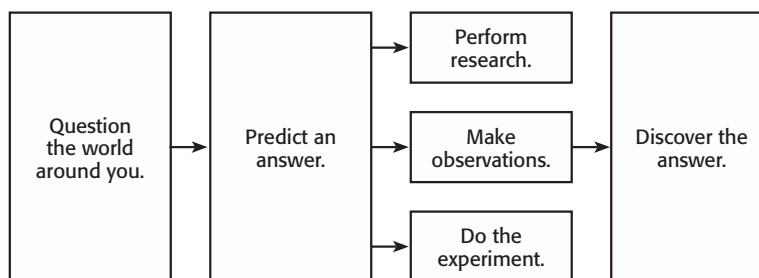

Research, observation, and experimentation are scientists' tools for searching for answers. Research and observation help scientists plan experiments. You can use these tools, too. A well-planned experiment may tell you the answer. It may even cause you to ask more questions.

SECTION 1 Science and Scientists *continued***How Do the Answers Affect Us?**

Although scientists cannot answer every question, they do find many interesting and helpful facts. Some of the answers help save people's lives, save Earth's resources, and protect our environment.

SAVING LIVES

Because scientists study moving objects, they have been able to answer the question, "How can passengers be protected during automobile accidents?" Scientists performed tests. As a result, airbags are now installed in cars. Drivers and passengers are required to wear seat belts. Motorcyclists are encouraged to wear helmets. ✓

CONSERVING RESOURCES

Science has also helped answer the question, "How can Earth's resources be made to last longer?" Recycling is one answer. Examples of used things that can be recycled are paper, aluminum, steel, glass, batteries, and tires.

Recycling rates have increased over the past 40 years. The table below shows how recycling of waste material has risen in the United States.

Year	Percentage of waste recycled
1960	6.4
1970	6.6
1980	9.6
1990	16.2
2000	30.0

PROTECTING THE ENVIRONMENT

Through the study of Earth's atmosphere, scientists found a serious problem. They discovered that the ozone layer, which protects the Earth from harmful rays from the sun, was getting thinner. They asked, "How can we protect the ozone layer?" Scientists researched, observed, and experimented. They found that chemicals used widely in spray cans destroyed the ozone when they rose up into the atmosphere. Today, different chemicals are used in spray cans. In addition, many things that used to be sold in spray cans are packaged differently.

 **READING CHECK**

5. List What are two results of scientists' study of moving objects?

Math Focus

6. Analyze Data Between which two years did recycling increase the most? About how much did it increase?

SECTION 1 Science and Scientists *continued*

Where Are Scientists Found?

Scientists work in many different places. Some like to study weather. Some are interested in studying rocks. All scientists are curious about the world around them. They ask questions and investigate to find answers.

METEOROLOGISTS

A meteorologist is a person who studies the changes in the atmosphere. (You might think they study meteors, but they don't.) Changes in the atmosphere cause our weather. Weather forecasters are often meteorologists. Some meteorologists study tornadoes. Some study hurricanes. They collect information about these violent storms. Meteorologists try to tell what areas storms will affect and how powerful they will be. ✓

READING CHECK

7. Describe How can meteorologists make people safer?

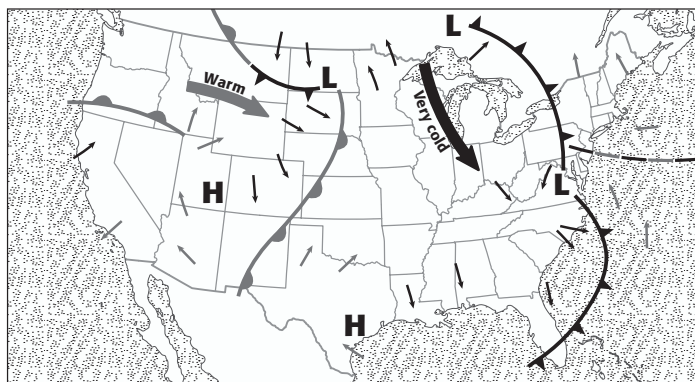

Meteorologists use weather maps to predict the weather.

GEOCHEMISTS

A geochemist is a scientist who studies rocks, minerals, and soil. Many geochemists work for mining companies. They look for gold, silver, diamonds, and iron ore. ✓

Oil is also found buried in deep places under land and sea. Many geochemists work for oil companies to help them find, remove, and refine the oil.

READING CHECK

8. Identify What do geochemists study?



This geochemist takes rock samples from the field. Then, she studies them in her laboratory.

SECTION 1 Science and Scientists *continued*

ECOLOGISTS

An ecologist studies living things and their nonliving surroundings. Ecologists are interested in plants and animals, including humans, and how they affect one another. They work in wildlife management, farming, forestry, and resource protection. ✓

VOLCANOLOGISTS

Volcanologists study volcanoes and the chemistry of Earth and all its layers. They find where volcanoes are located. They gather information to learn how and why volcanoes erupt. Volcanoes can be so powerful that they affect people all over the world. When scientists predict an eruption, they can save lives.



Volcanologists study volcanoes. Many volcanologists study volcanic patterns in order to predict when volcanoes will erupt.

SCIENCE ILLUSTRATORS

Science illustrators draw scientific diagrams. They use skills in art and science. They are needed in all areas of science, and especially in biology and medicine. ✓

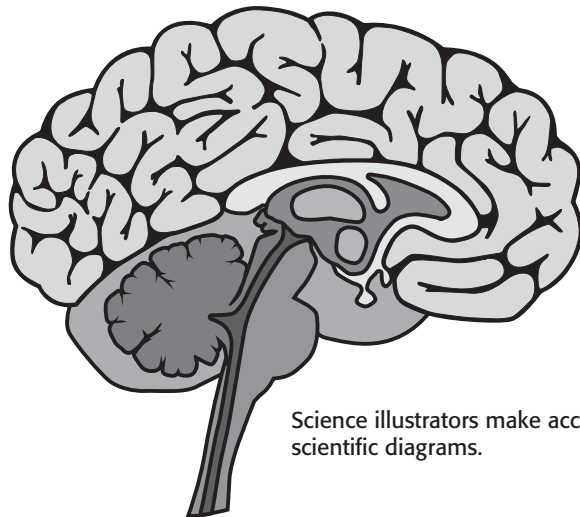

Science illustrators make accurate and clear scientific diagrams.

✓ **READING CHECK**

9. Identify What fields do ecologists work in?

 **Say It**

Research and Report

Choose a profession related to science, and research what people in that profession do on a daily basis. Report the results of your research to your class.

✓ **READING CHECK**

10. Identify What skills are needed by a science illustrator?

Section 1 Review

8.9.a



SECTION VOCABULARY

science the knowledge obtained by observing natural events and conditions in order to discover facts and formulate laws or principles that can be verified or tested

1. Identify What are three methods that scientists use for investigation?

2. Describe What are three sources of information scientists use when they do research?

3. Match Draw an arrow from the definition of the job to the type of scientist.

Studies volcanic eruptions

Measures wind speed of hurricanes

Draws diagrams of body parts

Knows how plants and animals affect one another

Knows how to remove oil from the ground

Science illustrator

Volcanologist

Geochemist

Meteorologist

Ecologist

4. Explain Tell two ways that scientists can help people.

5. Apply Concepts Your friend wants to know how much salt is added to the fries at her favorite burger restaurant. What would you suggest that she do to find out?

6. Use Data A scientist knows that a slow flow of lava travels at a rate of 3 m per day. Show how the scientist would determine how far the lava could travel in 30 days.

SECTION 2 **Scientific Methods**

BEFORE YOU READ

After you read this section, you should be able to answer these questions:

- What are the steps in the scientific method?
- How do scientists form a hypothesis?
- What do scientists do before telling others about their experimental results?



California Science Standards

8.9.a, 8.9.b, 8.9.c

What Are Scientific Methods?

Two scientists wanted to find a better way to move ships through the water. They thought that studying the way penguins swim might give them some ideas about how to improve ships. In this section, you will learn how these scientists used scientific methods to answer their questions.

Scientific methods are the ways in which scientists answer questions and solve problems. As scientists look for answers, they often use the same steps. However, there is more than one way to use the steps. Look at the figure below. ✓

This figure shows six steps that are part of most scientific methods. Scientists may use all of the steps or just a few steps during an investigation. They may repeat some of the steps or do the steps in a different order.

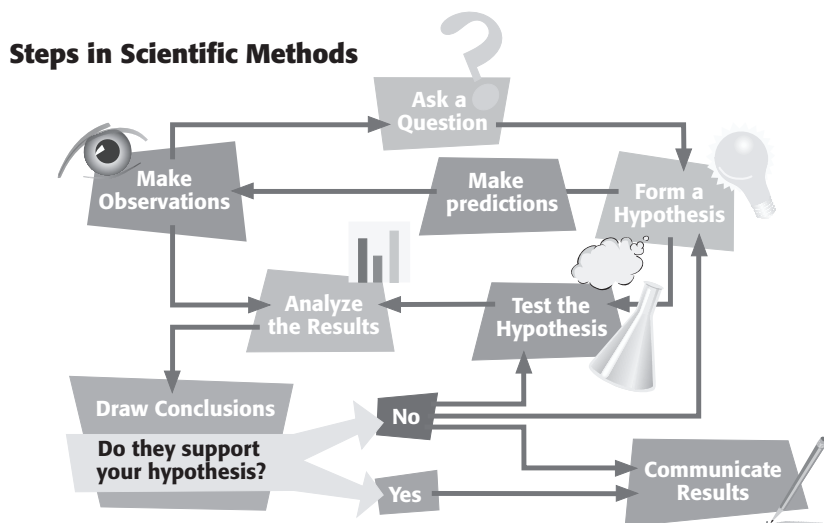

There are many steps in scientific methods. Notice that there are many ways to move through the different steps.

STUDY TIP

Outline As you read this section, make a chart showing how two scientists used the steps in scientific methods to improve ships.

READING CHECK

1. Describe What are scientific methods?

TAKE A LOOK

2. Identify What is the usual next step after analyzing the results?

SECTION 2 Scientific Methods *continued*

Why Do Scientists Ask Questions?

Asking questions helps scientists focus on the reason for an investigation. Questions arise after **observation**, which is collecting information by using the senses. A good example is the story of the two scientists who wanted to improve the way ships move through the water. This type of scientist is called an engineer. *Engineers* are scientists who build things based on scientific knowledge. ✓

READING CHECK

3. Describe Who are engineers?

Say It

Investigate Find out how the propeller of a ship works. Present your findings to your class or a small group.

REAL-WORLD EXAMPLE

Two engineers were studying how the propellers on ships work. They found that ships used a lot of fuel to push themselves through the water. Their job was to find a way to make ships move faster while using less fuel.

The engineers looked to nature to find a method to improve the efficiency of ships. A ship that is *efficient* does not use as much fuel as other ships to travel a certain distance. They observed sea animals in order to investigate what made them swim fast. The engineers noticed that penguins are master swimmers. Penguins have stiff bodies just like ships. However, they are able to push themselves through the water with ease.

Now the scientists were ready to ask their question. They wanted to know, “How can a ship’s propellers be built to push the ship through the water with ease?”



Penguins use their wings as flippers to “fly” underwater. As their wings are pulled inward, they push against the water. This movement pushes the penguins forward.

TAKE A LOOK

4. Identify How do penguins use their wings?

SECTION 2 Scientific Methods *continued*

How Do Scientists Form a Hypothesis?

Once a scientist has made observations and asked a question, he or she is ready to predict an answer. This is called forming a hypothesis. A **hypothesis** is a possible explanation or guess at an answer to a question. ✓

You must be able to test a hypothesis. A scientist tests a hypothesis by gathering more information or doing an experiment.

 **READING CHECK**

5. Describe What is a hypothesis?

POSSIBLE ANSWER FROM NATURE

The ship engineers had observed the slow movements of ships and the fast swimming of penguins. Their observations led them to make a hypothesis about how to propel a ship through water. They guessed, “A propulsion system that imitates the way a penguin swims works better than one that uses propellers.”

ANOTHER WAY TO WORD PREDICTIONS

Before scientists test a hypothesis, they may say what they think will happen in an *if-then statement*. An if-then statement makes the results easier to measure. The engineers’ prediction might have been: “If two flippers are attached to a boat, then the boat will be more efficient than a boat powered by propellers.”

The following table gives some examples of if-then statements.

If car A uses less gasoline than car B while taking the same trip,	then Car A is more efficient than Car B.
If it takes more force to stop an object with a large mass,	then it will take _____ force to stop a compact car than a large truck.
If a grape and an orange fall at the same rate,	then they will hit the ground at the _____ time when they are dropped from the same height.

Critical Thinking

6. Infer In the table, complete the “then” statements that have a missing word. Write each missing word on the line provided.

Why Does a Scientist Test a Hypothesis?

After you form a hypothesis, you must test it. You must find out if it answers your question correctly. Testing helps you find out if your hypothesis is pointing you in the right direction. You test a hypothesis by doing experiments.

SECTION 2 Scientific Methods *continued*

CALIFORNIA STANDARDS CHECK

8.9.c Distinguish between variable and controlled parameters in a test.

7. Identify Which of the parameters are both groups in an experiment exposed to?

CONTROLLED EXPERIMENTS

When scientists working for drug companies invent a medicine, they have to find out if the medicine will work. They usually test the drug on a large group of animals. Often, they work with special laboratory mice. All of the mice in the experiment have the same disease.

They divide the large group of mice into two smaller groups. One is called the *control group*. The other is the *experimental group*. The results from the experimental group are compared with those of the control group. In this way, scientists see if the drug had the expected effect.

Both groups should be about the same size and age. Size and age are called *factors* or *parameters*. These factors are characteristics of the mice. All of the factors for each group must be the same. These factors are called the *controlled parameters* of the experiment.

There is one factor that is different for each group. The control group will be given something called a *placebo*. It will not contain the drug being tested. The experimental group will be given the real drug. This difference is called the *variable parameter* of the experiment. ✓

The scientists watch carefully to see if the animals get better. It is important that the animals be treated exactly the same. The only difference is that the experimental group is given medicine.

READING CHECK

8. Describe When a new drug is being tested, what does the control group take instead of the real drug?

BUILDING A TEST BOAT

The engineers who were trying to design an efficient boat thought they should test their hypothesis by building one. They built *Proteus*, the penguin boat. It had flippers like a penguin so that the scientists could test their hypothesis about propulsion through the water.

Proteus, 3.4 m long and 50 cm wide, was a specially built boat used to test the “flippers” hypothesis.

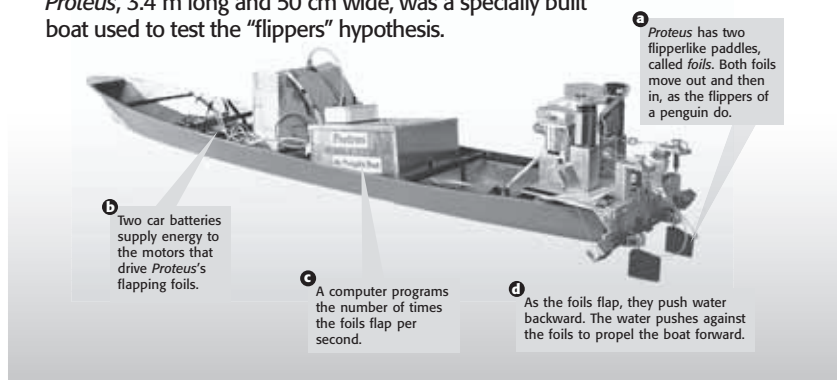

TAKE A LOOK

9. Identify Instead of a propeller, what is used by *Proteus* to move the boat through the water?

SECTION 2 Scientific Methods *continued***How Did the Scientists Test *Proteus*?**

Another way to have a controlled experiment is to repeat the test several times, changing one condition each time. That's what the engineers did with *Proteus*.

The engineers took *Proteus* to the Charles River in Boston. After putting the boat in the water, they were ready to collect data. **Data** are pieces of information collected from experiments. For each test, they paddled the boat across the river for the same distance with the same weather. ✓



Proteus, the “penguin boat,” was tested in the Charles River in Boston.

The engineers collected data on the speed of the boat and the amount of energy used to move the foils. The data recorded for the first trip were compared with the data from all of the other trips. The factor that was changed for each trip was the flapping rate of the foils. ✓

The experimental part of the test began with the second trip. The engineers increased the flapping rate, which was the variable parameter. Then they recorded the energy used and the speed. The engineers made several more experimental voyages. Each time, they set a different flapping rate and collected data on the energy used and the speed.

To find if the new design was efficient, they compared the amounts of energy used by the motors with the speeds of the boat on each trip. This step is called *analyzing* results.

 **READING CHECK**

10. Identify What two conditions stayed the same when *Proteus* sailed across the river?

 **READING CHECK**

11. Identify What factor was changed for each trip?

SECTION 2 Scientific Methods *continued*

How Do Scientists Analyze Results?

After you collect your data, you must analyze it. To *analyze* data means to interpret what the data mean. One way to analyze data is to organize them into tables and graphs. Tables and graphs make the relationships of the numbers easier to see. ✓

READING CHECK

12. Describe What does it mean to analyze data?

It's always a good idea to perform your experiment several times. Repeated tests tell you whether your data are accurate. If you get similar results every time and they support your hypothesis, then you know you are close to proving that your hypothesis is correct. Similar results on a number of tests show that your experimental data are *reproducible*. Reproducible data show other scientists that you designed a good experiment.

ANALYZING PROTEUS

The engineers calculated the data for energy used and the speed. They used the data to calculate *Proteus*' efficiency. Then they made the line graph below.

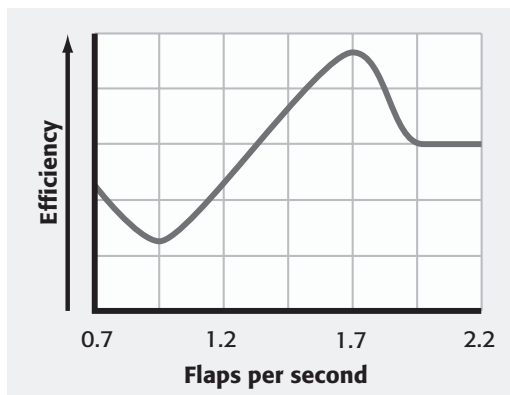

This graph shows the efficiency of *Proteus* when the flippers are moving at different rates.

Math Focus

13. Analyze When did *Proteus* show the highest efficiency?

They also used the data to compare *Proteus*' efficiency with the average efficiency of a propeller-driven boat. You can see the analysis of the results in the bar graph below.

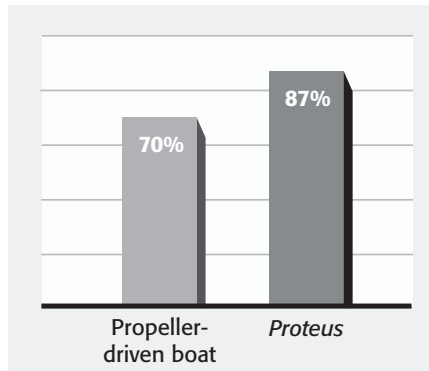

This graph shows the efficiency of *Proteus* compared with the efficiency of propeller-driven boats.

Math Focus

14. Compare Which boat was the more efficient?

How much more efficient was it?

SECTION 2 Scientific Methods *continued*

Was Your Hypothesis Correct?

At the end of the investigation, you must draw a conclusion. You do this by looking at your analysis. The results tell you if your hypothesis was correct. This is the same as saying that your results support your hypothesis.

It's also possible that you will come to a different conclusion. You may decide that your results do not support your hypothesis. If so, you can change the procedure, gather more information, or ask new questions. Whether your hypothesis is supported or not, the results are always important.

PROTEUS CONCLUSION

The engineers found that penguin propulsion was more efficient than propeller propulsion. They concluded that the results supported their hypothesis. ✓

The scientists were able to reach this conclusion because they did many tests. They were careful to have controlled parameters with only one variable parameter. They measured everything accurately. This proved that their results were not accidental. Their data showed the same relationship many times. Therefore, their results were reproducible.

Drawing a conclusion to support your hypothesis usually leads to more questions. More questions lead to more investigations. This is how scientific progress continues.

How Do You Tell Others About Your Results?

Other scientists will want to conduct their own tests based on your results. There are three ways to communicate the results of your investigation to them. You can use any or all of them. ✓

Ways to communicate the results of an investigation	Audience
Write a paper for a scientific journal.	scientists and others who read the journal
Give a talk.	scientists and others who are interested in the work
Create a Web site.	anyone interested in the work

Sharing your results allows other scientists to continue your work. Sharing also makes it possible for others to do your experiments and prove you were right.

 **READING CHECK**

15. Explain Why did the engineers feel that their hypothesis was correct?

 **READING CHECK**

16. Identify What are three ways scientists communicate the results of their investigations?

Section 2 Review

8.9.a, 8.9.b, 8.9.c



SECTION VOCABULARY

data any pieces of information acquired through observation or experimentation

hypothesis a testable idea or explanation that leads to scientific investigation

Wordwise The prefix *hypo-* means "under." The root *thesis* means "proposition." Other examples are *hypodermic* and *hypoallergenic*.

observation the process of obtaining information by using the senses

scientific methods a series of steps used to solve problems

1. Complete What are the steps that most scientific methods use?

Steps in Scientific Methods

2. Describe Why do scientists use scientific methods?

3. Explain A synonym is a word that has the same meaning as another word. What are two synonyms for *hypothesis*?

4. Explain Why must an experiment have a control group?

5. Explain What is a variable parameter?

6. List What was the variable parameter in the laboratory mice experiment? In the *Proteus* experiment?

CHAPTER 1 The Nature of Physical Science

SECTION

3

Safety in Science

BEFORE YOU READ

After you read this section, you should be able to answer these questions:

- What can you do to make the lab safe?
- What special precautions are necessary for working in a science lab?
- What is the safest way to respond to accidents?



California Science Standards

8.9.a

How Do You Keep Yourself Safe in the Lab?

You must be careful when you work in a science lab. It contains fragile glassware, liquids that can spill, and dangerous equipment. Accidents can happen to anyone, but you can take simple safety steps to avoid mishaps.

AVOIDING ACCIDENTS

Be aware of what is going on around you. Pay attention, follow directions, and watch what you are doing. When you put materials on the lab bench, be sure that they will not tip over. Learn to use all lab materials safely and correctly. Lab materials could include chemicals, heat sources, animals, and plants. ✓

Walk carefully around the lab area. Take care not to bump into anyone. Look out for others who are carrying liquids or breakable glassware.

Wear the right safety equipment. This equipment may include lab coats or aprons, goggles, and gloves. Some of the items pictured below are used for personal safety.



When you work in a science lab, your lab materials can include chemicals, heat sources, animals, and plants. All must be handled safely.

REPORTING ACCIDENTS

If you have an accident, no matter how small, tell the teacher right away.



List As you read this section, write down a list of mistakes that may be made in a lab. Also write down ways to correct or prevent them.



1. Identify Name four lab materials that need to be used carefully.

TAKE A LOOK

2. Identify In the figure, circle the piece of safety equipment that will protect your eyes.

SECTION 3 Safety in Science *continued*

What Special Precautions Do You Take in a Science Lab?

You will find special materials and equipment in the lab. Before you do experiments, you need to learn the correct ways to use the equipment.

UNDERSTANDING SAFETY SYMBOLS

Scientists use symbols to alert themselves. The symbols remind them to use certain precautions. The chart below lists the safety symbols.

Safety Symbols



Eye protection



Clothing protection



Hand safety



Heating safety



Electrical safety



Chemical safety



Animal safety



Sharp object



Plant safety



Say It

Identify On a blank piece of paper, draw several safety symbols. Have members of the class identify what the symbols represent.

FOLLOWING SAFETY SYMBOLS

Each symbol requires that you use specific precautions. For example, the symbol for heating safety has three safety measures. You need to clear your work area of materials that can catch fire. If you are wearing long sleeves, you need to roll them up. If you have long hair, you need to tie it back.

Your teacher will explain the meaning of each safety symbol. He or she will also tell you what preparations you must make.

FOLLOWING DIRECTIONS

Be sure to follow lab procedures exactly. Failure to follow directions is the most common cause of accidents. Your teacher has carefully planned directions to produce the best and safest results. Follow these rules:

- Read all procedures before beginning a lab activity.
- Ask for help on anything you don't understand.
- Ask your teacher if there is something you think should be done differently.
- Measure chemicals precisely (don't take more than you need).

 **READING CHECK**

3. Identify What is the most common cause of accidents?

SECTION 3 Safety in Science *continued*

NEATNESS

Working in a cluttered area is unsafe and unorganized. Clear your work area. Remove unnecessary books, backpacks, hats, and coats.

Clean up any chemical spill right away. Keep flammable objects away from Bunsen burners and other heat sources.

PROPER SAFETY EQUIPMENT

Safety equipment prevents accidents in the lab.

Eye Protection You need to wear safety goggles whenever you are handling liquids. The goggles should fit snugly. You can adjust them to fit your size. Eyeglasses are not enough. You need to have eye protection on the sides also.

Hand and Clothing Protection You need to wear gloves if you are handling plants, small animals, or certain chemicals. When handling warm objects, or using a hot plate or open flame, wear heat-resistant gloves.

Aprons Lab coats and aprons protect your clothing. Spills from certain chemicals can stain your clothes. Other chemicals can eat holes in your clothes.



Proper safety equipment should be used in a science laboratory.

CLEANING UP

When you have finished, you should do the following:

- Return all materials and chemicals to the proper place.
- Give damaged glassware to your teacher.
- Turn off all burners and hot plates.
- Wipe your work area with a damp paper towel.
- Wash your hands.

READING CHECK

4. Define What should you keep flammable objects away from in the lab ?

Critical Thinking

5. Explain Why is it dangerous to wear contact lenses when you are working with chemicals that are gases?

TAKE A LOOK

6. Identify Circle two sources of danger that goggles, heat-resistant gloves, and aprons protected you from.

SECTION 3 Safety in Science *continued*

How Do You Respond to Accidents?

Always tell your teacher if an accident happens. You should know where the safety equipment can be found.

EMERGENCY EQUIPMENT

Science labs have special emergency equipment. Your lab should have a fire extinguisher, a fire blanket, an eye bath, and a first aid kit.

Your teacher will know how to use them.



Make sure that you can locate and use the first-aid supplies and special safety equipment in your science lab. Your teacher can tell you the location of these supplies and the equipment and show you how to use them.

TAKE A LOOK

7. Identify Circle the first-aid kit, fire extinguisher, fire blanket, and eye bath in the figure.

PROPER ACCIDENT PROCEDURES

Make sure that you are safe. If there has been a spill, be careful that you don't slip on the floor. If some glassware has been broken, don't touch the glass.

Tell your teacher about any accident. He or she will take care of any injured students. Your teacher may have to perform first aid. **First aid** is an emergency care for someone who is hurt or sick. Sometimes, the student may need more serious medical help. A nurse or doctor is trained to help with serious injuries. ✓

READING CHECK

8. Describe What is first aid?

Critical Thinking

9. Identify What three pieces of safety equipment can probably prevent all the injuries described in the text?

PROCEDURES FOR ACCIDENTAL INJURIES

Care for an injury depends on the type of injury. Always tell the teacher. If you burn your hand, place it in cold water for 15 minutes. If you get a burn from a chemical, rinse the chemical off your skin. Then, place the burned area under cold, running water for 15 minutes.

If a chemical gets in your eyes, wash your eyes in the eye bath for 15 minutes. Then cover your eyes with a clean cloth.

If you cut yourself, rinse the cut gently. Then apply slight pressure with a clean cloth.

Section 3 Review

SECTION VOCABULARY

<p>first aid emergency medical care for someone who has been hurt or who is sick</p>	
---	--

1. Explain What is the first important rule when following directions?



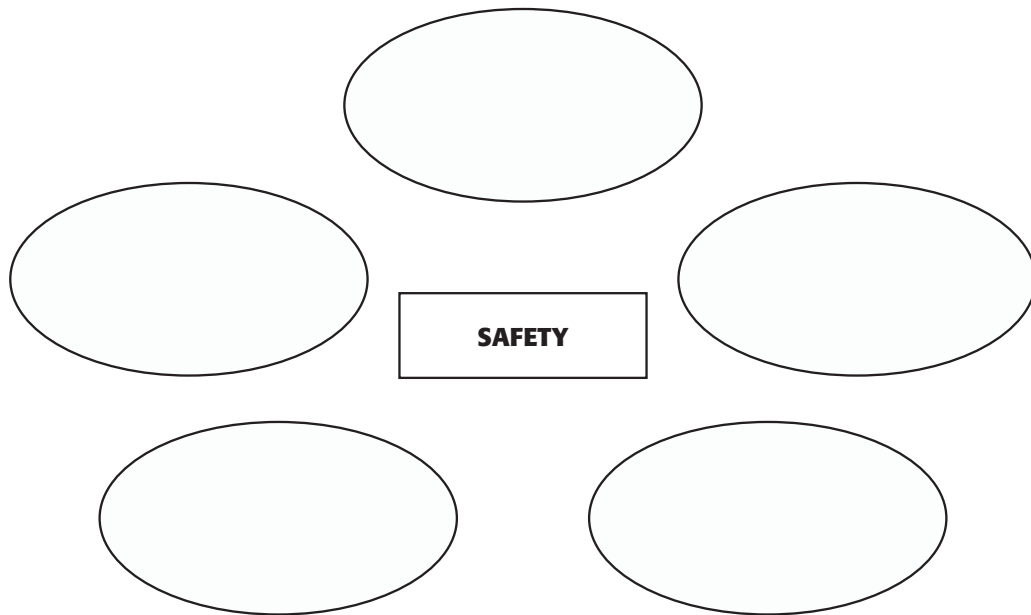





2. Complete Fill in the ovals in the Process Chart with the procedures that help keep you safe in the lab. Draw arrows from the procedures to the safety box.



3. List What types of safety equipment are found in your lab?

4. Explain After you tell your teacher, what should you do if you burn your hand?

5. Complete Under each safety symbol, write what it means.

				
_____	_____	_____	_____	_____
				
_____	_____	_____	_____	

SECTION 1 **Tools and Models in Science**



8.9.b, 8.9.f

BEFORE YOU READ

After you read this section, you should be able to answer these questions:

- How do scientists take measurements?
- What is the International System of Units?
- How do scientists use models to explain theories and scientific laws?



Map In your notebook, create a Concept Map about the SI units of measurement.

What Is a Tool?

Think about a tool that you have used. Whether it was a hammer, a drill, or a pair of scissors, the tool was something that helped you do a task. Scientists use tools when they do experiments, too. Most scientific data are collected by taking measurements. You can use a ruler or meter stick to measure length. The tool for measuring temperature is a thermometer. The figure below shows some of the tools that can be used in an experiment.

After you collect data, you need other tools to evaluate and analyze your results. Can you think of any tools for that? Calculators and computers are modern tools for analyzing data. You can also use the tools that came before calculators, such as graph paper.



1. Identify In the text, circle three tools for handling data.



Stopwatch

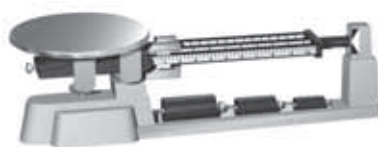

Balance



Ruler



Graduated cylinder



Thermometer

TAKE A LOOK

2. Identify Fill in each blank with the type of measurement each tool makes.

These are some of the tools that you can use to make measurements.

SECTION 1 Tools and Models in Science *continued***INTERNATIONAL SYSTEM OF UNITS**

Scientists use a metric system of measurement, in which all units are multiples of 10. It is called the International System of Units (SI). The abbreviation SI comes from its French name *Système Internationale*.

Each type of measurement has a base unit. For example, the meter is the base unit of length. SI uses prefixes for units that are larger or smaller than the base unit. When a prefix is put in front of a base unit, it changes how big the unit is. The table below shows some common prefixes and an example of how it changes the size of the base unit. ✓

Common International System of Units (SI) Prefixes

SI prefix	Symbol	Size	Example
mega	M	one million	1 Mg = 1,000,000 g
kilo	k	one thousand	1 km = 1,000 m
deci	d	one-tenth	1 dg = 0.1 g
centi	c	one-hundredth	1 cm = 0.01 m
milli	m	one-thousandth	1 mg = 0.001 g
micro	μ	one-millionth	1 μm = 0.000001 m
nano	n	one-billionth	1 ng = 0.000000001 g

LENGTH

The meter (m) is the SI base unit for length. Most people are between 1 m and 2 m tall. To measure shorter distances, you can use centimeters or millimeters. Scientists who work with atoms and molecules measure nanometers, which are billionths of a meter. A molecule that is 1 nm long is too small to see with the best light microscope. In the lab, you will usually use a meter stick or ruler to measure length.

MASS

Mass is the amount of matter in an object. The SI base unit for mass is the kilogram (kg). A medium-sized textbook has a mass of about 1 kg. You may measure the masses of small objects in grams, which are thousandths of a kilogram. The mass of a very large object, such as a ship or airplane, is often stated in units of metric tons. A metric ton is 1,000 kilograms. In the lab, you will use a balance to measure mass.

 **READING CHECK**

3. Describe When a prefix is put in front of a base unit, what does it do to the base unit?

TAKE A LOOK

4. Identify What does the prefix “d” mean? How many grams are in 1 dg?

Critical Thinking

5. Identify Relationships
How many times bigger is a metric ton than a kilogram?

SECTION 1 Tools and Models in Science *continued*

Math Focus

6. Make Comparisons How many mm long is a line that measures 15 cm?

 **READING CHECK**

7. Define What is the SI unit for temperature and its symbol?

TAKE A LOOK

8. Compare Determine the difference in temperature between the freezing point and boiling point of water on the Celsius scale and then on the Kelvin scale. How do they compare?

Common International System of Units (SI) Units		
Length	meter (m)	
	kilometer (km)	1 km = 1,000 m
	decimeter (dm)	1 dm = 0.1 m
	centimeter (cm)	1 cm = 0.01 m
	millimeter (mm)	1 mm = 0.001 m
	micrometer (μm)	1 μm = 0.000001 m
	nanometer (nm)	1 nm = 0.000000001 m
Volume	cubic meter (m ³)	
	cubic centimeter (cm ³)	1 cm ³ = 0.000001 m ³
	liter (L)	1 L = 1 dm ³ = 0.001 m ³
	milliliter (mL)	1 mL = 0.001 L = 1 cm ³
Mass	kilogram (kg)	
	gram (g)	1 g = 0.001 kg
	milligram (mg)	1 mg = 0.000001 kg
Temperature	kelvin (K)	0°C = 273 K
		100°C = 373 K

TEMPERATURE

The **temperature** of a substance is a measure of how hot or cold it is. The units of temperature normally used in the lab are degrees Celsius (°C). Outside the lab, you will often see temperature expressed in degrees Fahrenheit (°F). The SI unit of temperature is the kelvin (K). A temperature change of 1 K is the same as 1°C, but the systems start at different zero values. The degree sign is not used in the Kelvin scale. ✓

Many signs in front of businesses show the temperature in both the Fahrenheit and Celsius scales. On a warm day, a sign might alternate between 82°F and 28°C. The table below compares the Fahrenheit, Celsius, and Kelvin scales.

Fahrenheit, Celsius, and Kelvin Temperature Scales			
	Fahrenheit	Celsius	Kelvin
Freezing point of water	32°F	0°C	273 K
Normal body temperature	98.6°F	37°C	310 K
Boiling point of water	212°F	100°C	373 K

TIME

The unit of time in the SI system is the second, the same unit that your watch uses. Many scientific experiments are measured in seconds. Scientists often use nanoseconds or even smaller measures of time to measure the behavior of atoms, molecules, and light.

SECTION 1 Tools and Models in Science *continued***VOLUME**

Length is the measure of an object in one direction. To know how much space the object occupies, you need more information. **Volume** is the amount of space that something occupies. For example, the volume of a rectangular solid is its length multiplied by its width multiplied by its height.

The liter (L) is the unit often used to measure volume of liquids and gases. Liters are based on the meter. The SI unit of volume is the cubic meter (m³). One cubic meter (1 m³) is the same volume as 1,000 L. This means a box that is 1 meter on each side will hold exactly 1,000 L. ✓

Volumes of Selected Substances	
Substance	Volume
12 oz can of soda	355 mL
bar of gold	640 cm ³
tank of helium gas	50 L

How Can Measurements Be Combined?

Some quantities used in science are not measured directly. Instead, they are calculated by combining two or more measurements mathematically. Some important combined measurements are density and speed.

DENSITY

You have already learned that mass and the volume of an object can be measured. The values of mass and volume can then be combined to determine another property of matter, its density. **Density** is the amount of matter in a given volume. It's a measure of how compact matter is. For example, liquid water is denser than steam because it is more compact than steam. ✓

You cannot measure density directly. It is calculated by using the mass and volume of a substance in this formula:

$$D = \frac{m}{V}$$

In this formula, D represents the density of a material, m represents its mass, and V represents its volume. Density units used in science include grams per milliliter, kilograms per liter, and grams per cubic centimeter, but any combination of mass and volume can be used. The density of pure liquid water is 1.0 g/mL or 1.0 kg/L.

 **READING CHECK**

9. Define What is the SI unit for volume, and what is its symbol?

 **READING CHECK**

10. Define What is density?

SECTION 1 Tools and Models in Science *continued*

SPEED

Speed is a measure of the motion of an object. Speed is calculated by dividing the distance that an object moves by the time it takes to move that distance.

$$s = d/t$$

In this formula, *s* represents speed, *d* represents the distance, and *t* represents time. You are used to hearing speeds expressed in units of miles per hour or kilometers per hour. The most common unit of speed in the science lab is meters per second (m/s), but any combination of distance and time can be used. ✓

✓ **READING CHECK**

11. Identify What units would you use to measure the speed of a car on the highway?

What Is the Difference Between Accuracy and Precision?

Most people use the words *accuracy* and *precision* to mean the same thing. However, they do not mean the same thing. An accurate measurement means a measurement that is correct. A precise measurement means a measurement that is the same every time it is taken. This means that precise measurements can be reproduced.

For example, consider a line that is 15.3 mm long. Suppose that when you measure it five times, your measurement is 15.1 mm each time. Your measurement is not accurate, because it should have been 15.3 mm. However, it is precise because you got the same measurement each time.

Measurements that have good accuracy and good precision are called good data by scientists. These data are used to explain nature and make predictions about things that happen in nature.

What Are Models?

Look at the illustration below. It appears to be a space shuttle. However, the wire that holds it in place and the lack of exhaust gases shows it is a model.



Model of a Space Shuttle

 <p>CALIFORNIA STANDARDS CHECK</p>
<p>8.9.b Evaluate the accuracy and reproducibility of data.</p> <p>12. Evaluate While doing a lab, a student collects the following data on the speed of a car: 2.5 m/s, 2.0 m/s, 2.3 m/s, and 2.9 m/s. The correct speed is 2.5 m/s. Were any of the data accurate? Explain your answer.</p> <p>_____</p> <p>_____</p> <p>_____</p> <p>_____</p> <p>Do the data show reproducibility? Explain your answer.</p> <p>_____</p> <p>_____</p> <p>_____</p>

SECTION 1 Tools and Models in Science *continued***What Kinds of Models Do Scientists Use?**

A **model** is a way to represent an object or a system. A model uses something familiar to help you understand something that is not familiar. For example, a model of a human skeleton can help you understand how the body works. Models are also used to explain the past or to predict the future.

Scientists use three different types of models: physical, conceptual, and mathematical models. These three kinds of models are used to show different things about objects or concepts. Models cannot show everything, because a model is never exactly like the thing it represents.

PHYSICAL MODELS

Model airplanes, dolls, and drawings are all examples of physical models. A physical model can show the details of something that is too large or too small to observe directly. For example, maps and drawings of bacteria are physical models. Scientists and engineers can build a simple model of an object to investigate how it works.

CONCEPTUAL MODELS

The second kind of model is a conceptual model, which puts many ideas together to explain something. For example, the big bang theory is a conceptual model that explains why the universe seems to be expanding. Astronomers built the model to explain the data that they had collected.

The big bang theory says that 12 billion to 15 billion years ago, an event called the big bang sent matter in all directions. This matter eventually formed the galaxies and planets.

**MATHEMATICAL MODELS**

Mathematical models use equations and data to explain or predict things. Weather maps are based on mathematical models of thousands of observations. Other mathematical models are the equations used to calculate force and acceleration. Many mathematical models are so complex that you need computers in order to use them. ✓

**Say It**

Explore Applications A model is never exactly like the thing it represents. Sometimes the model is larger, sometimes smaller. Some models are the same size as the object but simpler. Discuss in a group what types of models you have used and how they help you understand the object and how it works.

 **READING CHECK**

13. Explain Why are computers needed for the mathematical models that represent weather?

SECTION 1 Tools and Models in Science *continued*

How Are Models Used?

Scientists use models to help represent ideas and objects. Models are also used to help you learn new information. Scientists often use models to explain concepts that are hard to understand. For example, an atom is much too small to see. However, a model of an atom can help you picture the parts of an atom and how atoms can combine with each other.

SCIENTIFIC THEORIES

In science, a **theory** is an explanation that combines many hypotheses and observations. A theory not only explains the observations, but it also makes predictions about what may happen in the future. Scientists use models to help organize information as they develop and test theories. ✓

Models can be changed or replaced as new information is added. The model of the structure of an atom has changed many times in the last 150 years. These changes have resulted in the model of an atom we use today.

READING CHECK

14. Describe What do models help scientists do as they develop theories?

TAKE A LOOK

15. Identify Which part of the spring models how molecules of air are close together?



The compressed coils in the spring toy can be used to model the way air particles are crowded together in a sound wave.

SCIENTIFIC LAWS

What happens when a model correctly predicts the results of many different experiments? Then a scientific law may be constructed. In science, a **law** is a summary of results and observations of many experiments. A law tells you how things work.

A scientific law is not a theory, because it does not explain why. For example, Newton's laws of motion explain how objects move. They let us accurately predict where an asteroid will be at a certain time 20 years from now. However, the laws of motion do not explain why the asteroid will be there. For that, you need to use the theory of gravity. Gravity explains the forces that cause bodies in space to attract each other over a distance.

Critical Thinking

16. Apply Concepts Picture the motion of a marble shot by a slingshot. Also picture the motion of a car on a race track. Which motion could you explain using a theory? Which could you explain using a law?

Section 1 Review

SECTION VOCABULARY

<p>density the ratio of the mass of a substance to the volume of the substance</p> <p>law a summary of many experimental results and observations; a law tell how things work</p> <p>mass a measure of the amount of matter in an object</p> <p>model a pattern, plan, representation, or description designed to show the structure or workings of an object, system, or concept</p>	<p>temperature a measure of how hot (or cold) something is; specifically, a measure of the average kinetic energy of the particle in an object</p> <p>theory an explanation that ties together many hypotheses and observations</p> <p>volume a measure of the size of a body or region in three-dimensional space</p>
---	---

1. **Identify** What formula relates mass, volume, and density?

2. **Classify** Fill in the blanks to complete the table of combined measurments.

What is calculated?	Formula	Unit
	$D = m/V$	kg/m ³
	$V = l \times w \times h$	m ³
Speed		

3. **Analyze Processes** To determine the density of a liquid, you measure its mass and its volume several times. What must the data show if they are good data? What must be the density of the liquid if the data are good?

4. **Analyze Ideas** Why did scientists agree to use the SI units worldwide instead of the units common at their locations?

5. **Make Calculations** If a bike rider travels 4 km in an hour, what is his speed measured in miles per hour?

SECTION 2 **Organizing Your Data**



8.9.c, 8.9.e, 8.9.g

BEFORE YOU READ

After you read this section, you should be able to answer these questions:

- Why do scientists use data tables and graphs?
- What are dependent variables and independent variables in an experiment?
- What are linear and nonlinear graphs?

STUDY TIP

Ask Questions Read this section silently. In your notebook, write down questions that you have about the section. Discuss your questions in a small group.

How Do You Make a Data Table?

Have you ever started to do your homework and found that you have too much information? It can be hard to keep track of everything at one time. Scientists performing experiments also have to deal with a lot of information. For their data to be useful, they must be organized. This section will discuss some of the ways scientists organize data to make them easier to understand.

The first step is to know what kind of information you can gather from the experiment. Then, you can build a data table before you start. That helps keep all of the information organized so that nothing important is missed. A data table records the variables from an experiment. ✓

READING CHECK

1. Identify What is recorded on a data table?



Too much information can be overwhelming if it is not organized.

SECTION 2 Organizing Your Data *continued*

INDEPENDENT AND DEPENDENT VARIABLES

Look at the data table below. It has two columns that list two kinds of information that are related to each other. The first column shows the values for the independent variable. The **independent variable** is the factor that the experimenter decides to change or control. This experimenter is studying the number of hours a class exercises each week. The independent variable is the week during which data are recorded.

The second column in the data table shows the values for the dependent variable. The **dependent variable** is the factor that changes because the independent variable has changed. In the data table, the dependent variable is the number of hours exercised. This number varies depending on which week is studied. ✓

READING CHECK

2. Compare How does the independent variable differ from the dependent variable?

Creating a Data Table

Week	Time exercised
1	40 h
2	47 h
3	44 h
4	50 h
5	53 h

The first column contains the independent variable.

Labeling the columns is important.

The second column contains the dependent variable. Correct units should be included.

TAKE A LOOK

3. Explain Why is it important to label the columns in a data table?

VARIABLE AND CONTROLLED PARAMETERS

When you design an experiment, you must consider a number of things. *Controlled parameters* are things or conditions that do not change. For example, in the exercise experiment, the data must include the same student each week. Also, the same activities are recorded as exercise each week. These are controlled parameters. *Variable parameters* change during the experiment. The total number of hours of exercise is a variable parameter in this experiment.

Critical Thinking

4. Evaluate Methods Why do all of the parameters, except the independent variable, have to be controlled?

SECTION 2 Organizing Your Data *continued*

How Can You Use Graphs?

Data tables help organize data. Graphs help you understand and use the data. Graphs are used to see trends and to make predictions. By graphing the data in the experiment on the previous page, you can see any changes in the amount of exercise over time.

AXES

The illustration in the figure below shows how to make a graph. First, use a data table to determine the axes (singular, *axis*) of the graph. An **axis** is a reference line that forms one side of a graph. The horizontal axis is called the *x*-axis, and the vertical axis is the *y*-axis. On a graph, the *x*-axis is the independent variable, and the *y*-axis is the dependent variable ✓

READING CHECK

5. Identify Which axis is generally used for the independent variable?

Labels on the axes show which variables they represent. In the graph below, the *x*-axis shows which week the data were collected. The *y*-axis shows the number of hours of exercise.

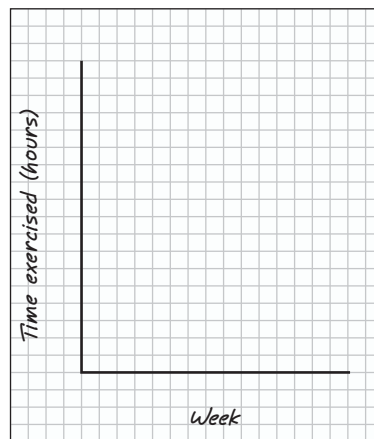
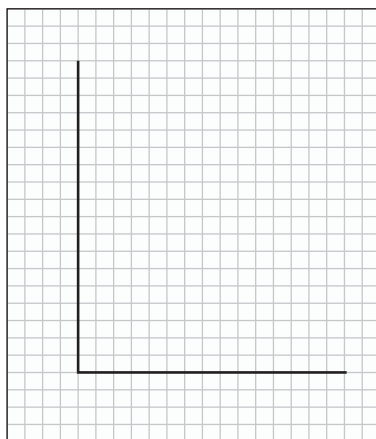

TAKE A LOOK

6. Describe What two things does each label on a graph tell you?

Drawing the Axes Your horizontal and vertical axes should be long enough to fit all of your data.

Labeling Your Axes Each axis should have a label and, when needed, the correct unit.

RANGE

Each axis has a range, or the spread of values to be recorded. To find the range, subtract the smallest value of the variable from the largest value. For this graph, the range of the *x*-axis (independent variable) is 5 weeks. That means the *x*-axis must cover a time of at least 5 weeks. The range of the *y*-axis (dependent variable) is 53 hours minus 40 hours, or 13 hours. So, the *y*-axis of the graph has to have enough room for at least 13 hours. ✓

READING CHECK

7. Identify What is the term used to describe the spread of values of a variable?

SECTION 2 Organizing Your Data *continued*

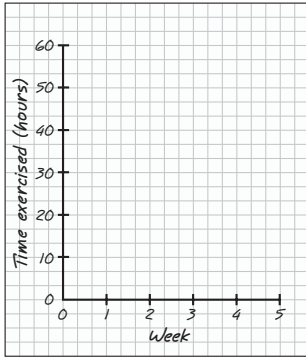

Determining Range and Scale
Each axis on a graph has its own scale so that the data can be easily seen.

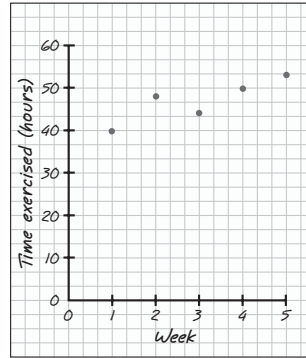

Plotting the Data Points
The easiest part of creating a graph is taking pairs of data and putting them where they belong.

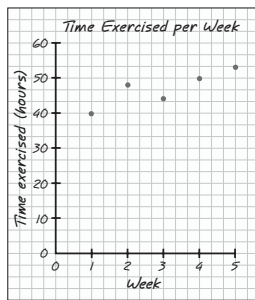

Labeling the Graph Every graph needs a good title that tells the reader what the graph is all about.

SCALE AND DATA POINTS

The next step is choosing a scale for the graph, as shown in the figure above. Each axis has a scale—the size used for each box or grid mark. For the exercise data, a scale of 1 week is used. The weeks are spaced so that the range fits across the graph. Each week is marked with a grid mark, or short line. For the *y*-axis, grid marks are placed at a scale of 10 hours.

The scale should be chosen so that the graph spreads out to fill most of the available space. Each axis is labeled to tell what information it shows. If the measurement includes units, such as meters or seconds, these units are also shown on the axis.

Once the scale is marked, you add the data points by putting dots on the graph. Each dot represents one set of information. In this case, each dot represents the amount of time exercised in a particular week. Data points are shown in the figure above.

TITLE

Every graph needs a title that helps the reader figure out what it shows. The title should be fairly short. It usually includes information about the variables.

Math Focus

8. Read a Graph Use one of the graphs to find how many hours the class exercised during week 4.

CALIFORNIA STANDARDS CHECK

8.9.e Construct appropriate graphs from data and develop quantitative statements about the relationships between variables.

Word Help: appropriate correct for use; proper

9. Analyze Relationships
Based on the data on the graph in the figure, did the amount of exercise increase, decrease, or stay the same during the period in which data were recorded?

SECTION 2 Organizing Your Data *continued*

What Patterns Do Graphs Show?

The graph below shows the data points that were plotted on the previous page. Notice that a line has been added. Normally, on a graph, points are not connected dot to dot. Instead, a “line of best fit” is drawn to show the pattern in the data.

The pattern shown by a straight line sloping up to the right is called a *direct relationship*. This means that as the independent variable increases, the dependent variable increases. A straight line sloping to the left is called an *inverse relationship*. This means that as the independent variable increases, the dependent variable decreases.

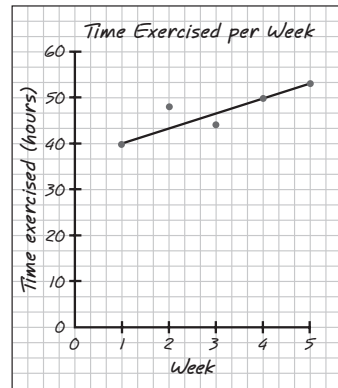

A graph shows the general relationship between two variables. The line that shows the relationship may not go through each point. Instead, it is the **line of best fit** for the data. A straight line shows a linear relationship.

TAKE A LOOK

10. Explain How can you tell that the relationship shown by the graph is a direct relationship?

LINEAR AND NONLINEAR GRAPHS

Graphs make it easy to see if something is increasing, decreasing, or staying the same. If the relationship between the independent and dependent variables can be shown with a straight line, as in the figure above, the graph is called a *linear graph*.

Sometimes the relationship between variables is not a straight line, but a smooth curve. If the data cannot be shown with a straight line, the graph is *nonlinear*. The figure below shows two examples of nonlinear graphs.

Trends in Nonlinear Graphs

TAKE A LOOK

11. Identify On a graph, what indicates whether a relationship is nonlinear direct or nonlinear inverse?

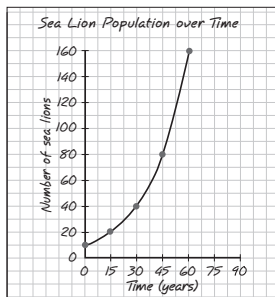

Inverse Nonlinear Relationship
The dependent variable decreases as the independent variable increases.

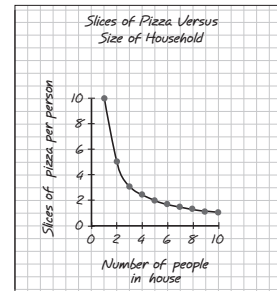

Direct Nonlinear Relationship
The dependent variable increases as the independent variable increases.

Section 2 Review

8.9.c, 8.9.e, 8.9.g



SECTION VOCABULARY

axis one of two or more reference lines that mark the borders of a graph

dependent variable in an experiment, the factor that changes as a result of manipulation of one or more other factors (the independent variables)

independent variable in an experiment, the factor that is deliberately manipulated

Wordwise The prefix *in-* means “not.” Other examples are *ineffective* and *insane*.

1. Explain Why are the dependent and independent variables plotted on different axes of a graph?

2. Compare On the first grid, draw a line showing an inverse linear relationship. On the second grid, draw a line showing a direct nonlinear relationship.

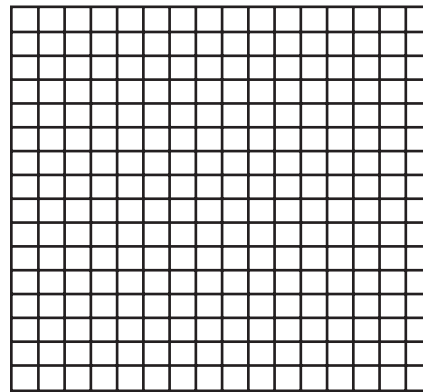
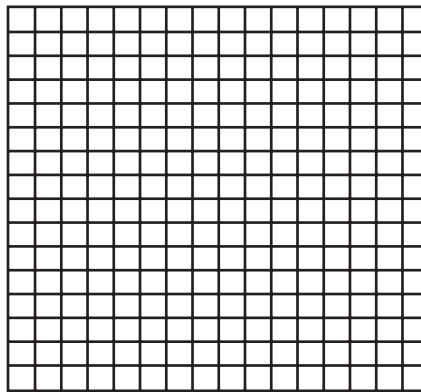

3. Analyze Processes Why is it necessary to have an independent variable that is changed by the experimenter during an experiment?

4. Draw Conclusions What conclusion can you draw if the line of best fit on a linear graph does not slope either up or down but is horizontal?

5. Apply Ideas Your class performed an experiment to determine the effect of the amount of light on plant growth. Some plants received 4 hours of light every day, while others received 6, 8, or 10 hours. After two weeks, you measured the height of the plants. What are the dependent and independent variables in the experiment?

SECTION 3 Analyzing Your Data



8.9.b, 8.9.d

BEFORE YOU READ

After you read this section, you should be able to answer these questions:

- Why is mathematics an important tool for scientists?
- How do accuracy and reproducibility of data affect the conclusions of scientific studies?
- How can linear equations and graphs help analyze data?

STUDY TIP

Clarify Concepts Take turns reading this section out loud with a partner. Stop to discuss ideas that seem confusing.

Why Is Mathematics Important?

Mathematical models are used in making complicated aircraft such as the space vehicle shown below. Engineers use mathematics to predict how the vehicles will work before the first one is built.

Mathematics is used by scientists to answer questions. It helps them to find out the properties of materials, and it allows scientists to organize information. This information is used to make predictions. For example, meteorologists gather large amounts of data about hurricanes and use mathematics to predict a hurricane’s path.

Mathematics also allows scientists to communicate information. Even if they speak different languages, two scientists from different countries use mathematics in the same way. Because it allows people to share their findings in a common way, mathematics is often called the language of science. ✓

READING CHECK

1. **Explain** Why is mathematics referred to as the “language of science”?

Say It

Discuss Why is it important to use mathematical models before building a large flying machine? Discuss in a small group what other kinds of projects would use mathematical models.



On October 4, 2004, SpaceShipOne rocketed into history. It became the first non-government spacecraft to exceed an altitude of 328,000 ft twice within the span of a 14-day period. For being the first privately owned spacecraft to do this, it won \$10,000,000.

SECTION 3 Analyzing Your Data *continued*

The most accurate reading of the liquid's volume is made by looking at the bottom of the meniscus at eye level.

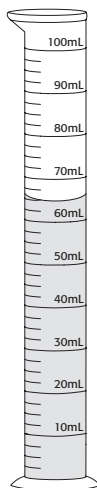

TAKE A LOOK

2. Identify What is the volume of the liquid in the graduated cylinder?

How Can You Be Sure Data Is Accurate?

When scientists collect data, they want to be certain that it is accurate. That is, they want the results to be correct. For example, suppose a scientist places an object with a mass of 450 g on a balance. If the balance gives a reading of 525 g, the reading is inaccurate. Causes of inaccurate data include broken equipment, using the wrong tool, and using a tool incorrectly.

The first step in getting an accurate measurement is using the right tool. The graduated cylinder in the figure above will let you get much more accurate readings than a kitchen measuring cup will. The ruler that shows millimeter markings allows more accuracy than a ruler whose smallest intervals are centimeters.

Accurate data require more than just the right tool; you also have to use the tool correctly. With a graduated cylinder, you will get an inaccurate result if you don't read the volume with the bottom of the meniscus at eye level. To get an accurate reading on a ruler, you need to look straight down at the object being measured. If your head is to the side, your reading will be a bit different.

Critical Thinking

3. Analyze Methods If you wanted to measure the width of the gym, how would the accuracy of a meter stick compare with that of a 50 m tape? Explain your answer.

What Is Reproducibility?

When scientists do an experiment, they expect it to be repeated, or reproduced, by other scientists. If someone else uses the same process and equipment, they should get the same result. If the data cannot be reproduced, then other scientists will not accept the results. If you want other people to agree with your conclusions, your data must be reproducible.

SECTION 3 Analyzing Your Data *continued*

How Can You Describe a Data Set?

When scientists analyze data, they often find it helpful to use a single number to describe the entire set of data. Three measures that are used to do this are the *mean*, the *median*, and the *mode*. The figure below shows how these measures are determined.

The **mean** is also called an “average.” It is found by adding the data points together, then dividing the total by the number of data points. The **median** is the value of the data point in the middle when the data are placed in order from smallest to largest. The median is useful for describing data when one point is much larger or smaller than the rest of the data. The **mode** is the number that appears most often in a data set. ✓

READING CHECK

4. Identify Which measure refers to the value of the point in the middle of the data set?

Analyzing the Entire Set of Data

Week	Time exercised
6	40 h
7	46 h
8	43 h
9	96 h
10	40 h

Finding the Mean

Add your data together.
Divide the sum by the number of observations in your data set.

40
46
43
96
40
Sum = 265

Mean =
 $265 \div 5$
Mean =
53 hours exercised

Math Focus

5. Evaluate Data Find the mean and the mode of the following data set: 8, 12, 10, 8, 7.

Finding the Mode

Place your data in order from smallest to largest. The number that appears most frequently is the mode.

40, 40, 43, 46, 96

Mode =
40 hours exercised

Finding the Median

Place your data in order from smallest to largest. The number in the middle is the median.

40, 40, 43, 46, 96

Median =
43 hours exercised

6. Apply Concepts What is the median of the following data set: 52, 48, 66, 66, 8?

SECTION 3 Analyzing Your Data *continued*

How Can You Find and Use the Slope of a Line?

When you talk about skiing downhill, the trail you follow has a slope. In math, **slope** is defined as the degree of slant of a line. To calculate the slope of a line, you use two values called the *rise* and the *run* of the line. The rise is the vertical change. On your graph, the rise is the change in *y*, or the number of units moved up or down. The run is the change in *x*, or the number of units moved to the right or left. ✓

The slope of a line is determined by dividing the vertical change by the horizontal change. In other words, the slope of a straight line is found by dividing the rise by the run. This is often called “rise over run.”

The slope of the line of graphed data can help you analyze the data. Graphs below show two sets of data. For each line, the value of the slope between any two points will be a constant number.

In this example, the slope represents the speed (in meters per second) of an object moving at a constant rate. Notice that the units of the slope are the units of the *y*-axis divided by the units of the *x*-axis. The slope can be positive or negative, as shown. If a line is horizontal, its slope is zero. In this case, a slope equal to zero shows that the object isn't moving. It is stationary.

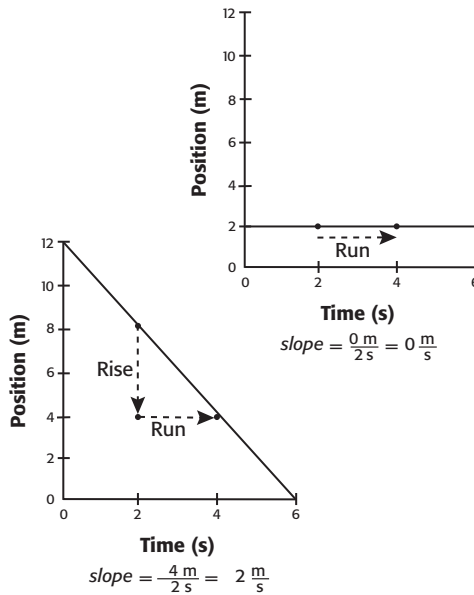
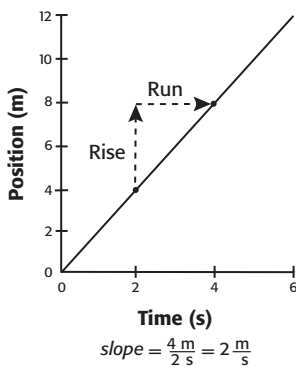

The results of three sets of data can be graphed to analyze data. Here, the slope of a line on a position versus time graph gives the speed of the object.

READING CHECK

7. Identify What kind of change is represented by the rise of a line? By the run?

TAKE A LOOK

8. Define What happens to the value of *y* as *x* increases if the slope is negative?

SECTION 3 Analyzing Your Data *continued*

SLOPE AS A CONSTANT

Some experiments result in a graph that is a straight line beginning at $x = 0$ and $y = 0$, the origin of the graph. In this case, the equation $y = kx$ can be used to represent the data. The letter k represents a constant term, which is equal to the slope of the line. The slope of a straight line has only one value.

This kind of graph is shown below. In this graph, the y -axis represents the measurement of the mass of a piece of lead. The volume measurement is represented by x . The graph is linear, in the form $y = kx$. The value of k is the density of lead. Substituting the letters used for mass, volume, and density in the equation gives the equation $m = DV$.

CALIFORNIA STANDARDS CHECK

8.9.d Recognize the slope of a linear graph as the constant in the relationship $y = kx$ and apply this principle in interpreting graphs constructed from data.

Word Help: constant
a quantity whose value does not change

9. Analyze Relationships
From the graph at right, how do you know that density is a constant?

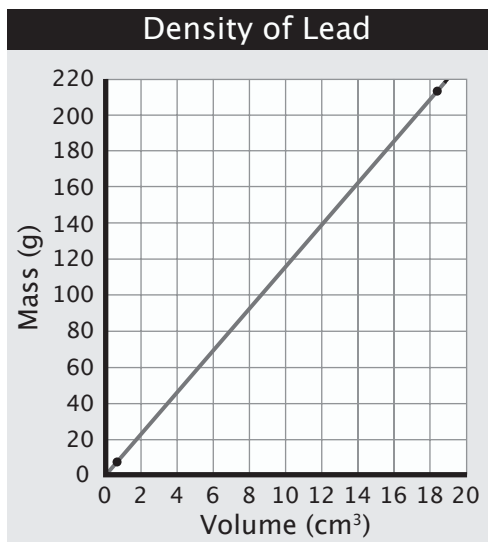

The line in the graph above represents the constant density of lead. When the mass and volume measurements for the two lead fishing weights are plotted, the data points fall on the line in the graph.

How Do Linear and Nonlinear Graphs Compare?

The lines on a graph can help you draw conclusions about the data. The slope of a straight line has only one value. This means that the change in y is always the same amount for a particular change in x .

Many of the relationships that scientists study are not linear. In a nonlinear graph, a change in x does not cause the same change in y . The graph of this kind of relationship forms a curved line instead of a straight line. In a nonlinear relationship, there is no one slope that applies to all the data.

Section 3 Review

8.9.b, 8.9.d



SECTION VOCABULARY

mean the number obtained by adding up the data for a given characteristic and dividing this sum by the number of individuals

median the value of the middle item when data are arranged in order by size

mode the most frequently occurring value in a data set

slope a measure of the slant of a line; the ratio of rise over run

- 1. Calculate** Determine the mean, median, and mode for this data set: 12, 10, 6, 9, 6, 7, 6. Show how you calculated the mean.

- 2. Classify** Fill in the blanks to complete the table.

Measure	What it is
	rise over run on a linear graph
Median	
Mode	
	the average value of a data set

- 3. Draw Conclusions** You perform an experiment concerning the number of different types of seed and the number of birds at your bird feeder. After collecting data for a week, you plot it on a graph and find that the line of best fit is a horizontal line. What conclusion can you make?

- 4. Apply Concepts** A graph is made that plots the distance a car moves, in meters, on the y -axis. The time it takes to move that distance, in seconds, is shown on the x -axis. What would calculating the slope tell you about the car's motion? What are the units of the slope?

- 5. Evaluate Data** A student collects the following data for aluminum: mass equals 24 g, and volume equals 6.0 cm³. The known density of aluminum is 2.7 cm³. Are the student's data accurate? Show your work.

$$D = \frac{m}{V} = \frac{24 \text{ g}}{6.0 \text{ cm}^3} = 4 \text{ g/cm}^3$$

What Is Matter?



California Science Standards

8.8.b

BEFORE YOU READ

After you read this section, you should be able to answer these questions:

- What are the properties of matter?
- What is volume?
- What is mass?
- How is weight different from mass?

STUDY TIP

Organize Information In your notebook, make a table with three columns. Title them Property of Matter, Definition, and Unit of Measure. As you read this section, fill in the columns.

READING CHECK

1. Identify Give a unit of measure for each of the following:

volume _____

mass _____

weight _____

READING CHECK

2. Define What is volume?

What Is Matter and Some of Its Properties?

You are made of matter. **Matter** is anything that has mass and takes up space. A toaster, a glass of water, and the air around you are all made of matter.

Matter can be described by its properties. Several properties of matter are volume, mass, and weight. The liter (L) is a scientific unit of volume. The kilogram (kg) is the SI unit for mass, and the newton (N) is the SI unit of weight. ✓

What Is Volume?

All matter takes up space. The amount of space that an object takes up, or occupies, is known as the object's **volume**.

Imagine a car driven into a swimming pool filled to the top. Some water would splash out. This would happen because the car and the water have volume. Two objects can't occupy the same volume at the same time. ✓

UNITS OF VOLUME

The SI unit of volume is the cubic meter (m³). The figure below shows how big a cubic meter is.



This girl is sitting in a 1 m³ box and holding a meter stick.

Math Focus

3. Convert The volume of a half-gallon carton of milk is 1.9 L. How many milliliters is this?

The liter is used more often than the cubic meter as the scientific unit for measuring volume. Small volumes of liquid are often given in milliliters (mL). Remember that 1 L equals 1,000 mL. Any volume of liquid can be described in liters or milliliters. For example, the volume of a small can of soda is measured as 0.355 L or 355 mL.

SECTION 1 What Is Matter? *continued*

MEASURING LIQUID VOLUME

At home, you may use a measuring cup to determine a liquid’s volume. In class, graduated cylinders are used to measure liquid volume accurately.

When you measure an amount of liquid, you must be careful. If you look closely, you will see that the surface of water is curved in a glass container. The curve of the surface of a liquid is called a **meniscus**. ✓

The meniscus may curve only a small amount and may look flat in a large glass container. The amount of a liquid in a container is measured from the lowest point of the meniscus. When you look at the figure below, you can see a meniscus.

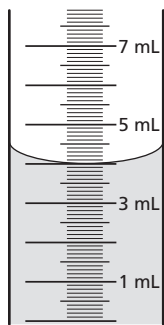

To measure volume correctly, read the scale at the lowest point of the meniscus. The volume is read as 4.0 mL.

VOLUME OF A REGULARLY SHAPED SOLID OBJECT

The volume of any regularly shaped solid object is measured in cubic units. The word *cubic* means that the object is not flat. The volume of an object is calculated by multiplying three measurements: length, width, and height.

Cubic measurements are different from square measurements, which are used for area. The area of an object is flat. It is calculated by multiplying only two measurements: length and width. The figure below shows the difference between volume and area. ✓

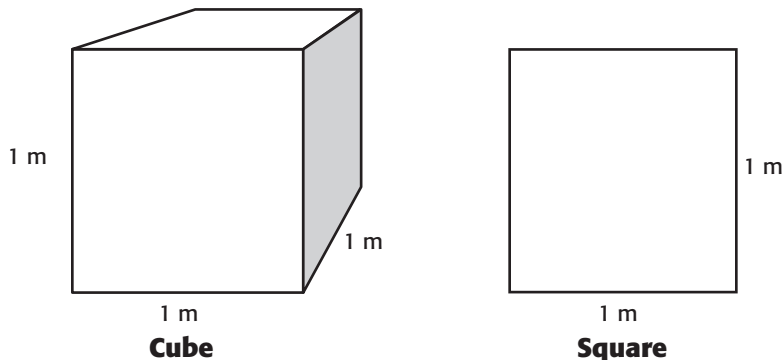

The cube has volume. Each face of the cube has area. The square has only area.

READING CHECK

4. Describe What is a meniscus?

TAKE A LOOK

5. Draw On the figure draw a meniscus that would show a volume of 6.0 mL.

READING CHECK

6. Identify What do cubic measurements measure?

7. Identify What do square measurements measure?

Critical Thinking

8. Find What is the area of each face of the cube shown in the figure? Remember that area is length times width.

SECTION 1 What Is Matter? *continued*

FINDING THE VOLUME OF A REGULARLY SHAPED OBJECT

There is a formula for calculating the volume of a regularly shaped object, such as a cube.

$$V = 1\text{ m} \times 1\text{ m} \times 1\text{ m} = 1\text{ m}^3$$

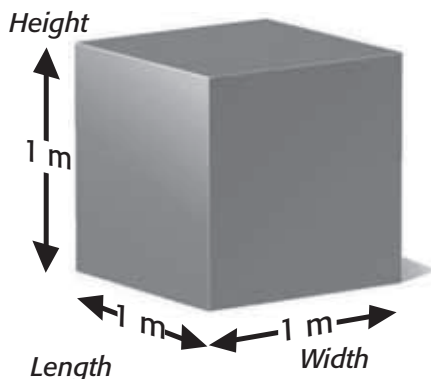

A cube whose length, width, and height are each 1 m has a volume of one cubic meter (1 m³).

To find the volume (*V*) of a regularly shaped object, multiply the area (*A*) and height (*h*), as shown in the following formula:

$$V = A \times h$$

For example, find the volume of a box that has an area of 400 cm² and a height of 10 cm.

$$V = A \times h$$

$$V = 400\text{ cm}^2 \times 10\text{ cm} = 4,000\text{ cm}^3$$

VOLUME OF AN IRREGULARLY SHAPED OBJECT

One important way to measure the volume of an irregularly shaped object is to put it into a known volume of water. The increase in total volume is equal to the volume of the object.

Remember that objects cannot occupy the same space at the same time. The figure below shows how much water is displaced, or moved, after an object is dropped into it.

READING CHECK

9. Describe You are given a toy metal car and asked to find its volume. Describe how you would do this.

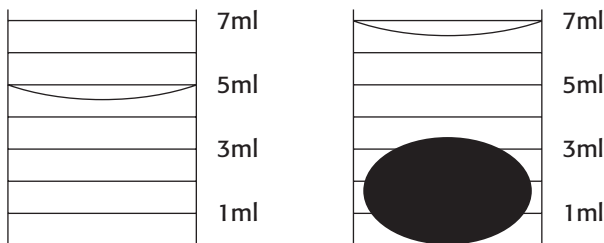

The irregularly shaped solid makes the total volume 2 mL larger. So, its volume is 2 mL.

SECTION 1 What Is Matter? *continued***What Is Mass?**

Another property of matter is mass. **Mass** is a measure of the amount of matter that makes up an object. For example, both you and a penny are made of matter. You are made up of more matter than the penny, so you have a greater mass. ✓

The mass of an object does not change when the location of the object changes. The mass of any object changes only when the amount of matter that makes up the object changes.

DIFFERENCE BETWEEN MASS AND WEIGHT

You may think that mass and weight are the same thing, but they are very different. **Weight** is the measure of the force of gravity on an object. Earth has a force of gravity that keeps all objects from floating into space. When you step on a scale, you are seeing the force with which Earth pulls on you. This is known as your weight. ✓

An object's weight can change, depending on where the object is located. On the other hand, the mass of the object stays the same. For example, a penny weighs less on the moon than here on Earth. This is because the moon exerts a smaller force of gravity than Earth does. However, the mass of the penny, or the amount of matter it has, stays the same. Only the force changes.

The table below shows how mass and weight differ.

	Mass	Weight
How it is measured	with a balance	with a scale
What is measured	amount of matter	force of gravity
SI measurement units	kilograms	newtons
Effect of moving it (for example, to the moon)		

 **READING CHECK**

10. Describe What does the mass of an object measure?

 **READING CHECK**

11. Identify When you step on a scale, what is being measured?

 **Say It**

Discuss Form a small group. Discuss what it would be like to have a soccer game on the moon. Think about the weight of the ball and how large the field might be.

TAKE A LOOK

12. Complete Write either "none" or "change" in each of the two empty boxes in the table.

SECTION 1 What Is Matter? *continued*

MEASURING MASS AND WEIGHT

The brick and the sponge in the figure below have the same volume. However, because the brick has more mass, Earth pulls on the brick more than it does on the sponge. So, the brick weighs more than the sponge.

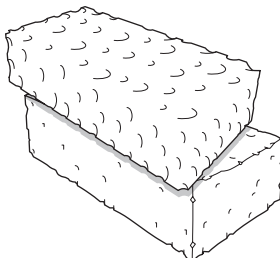

The brick and the sponge take up the same amount of space. The brick contains more matter, so its mass—and thus its weight—is greater.

The SI unit for mass is the kilogram (kg). Smaller masses are often measured in grams (g) or milligrams (mg). These units can be used to give the mass of any object. ✓

READING CHECK

13. Identify Name three mass units.

Weight is a measure of gravitational force. The SI unit of weight is the newton (N). One newton is equal to the weight on Earth of an object with a mass of about 100 g. ✓

How Much Would You Weigh on Another Planet?

Have you ever wondered what it would be like visiting another planet or the moon? Would the ground feel the same? Would you feel heavier or lighter?

The table below shows what your weight would be on some other objects in our solar system.

Object in our solar system	Weight (lbs)	Weight (N)
Moon (Earth's)	20	89
Mars	45	200
Venus	110	480
Earth	120	530
Saturn	140	620
Jupiter	320	1,400

READING CHECK

14. Identify What is the SI unit for force and its symbol?

Section 1 Review

SECTION VOCABULARY

<p>mass a measure of the amount of matter in an object</p> <p>matter anything that has mass and takes up space</p> <p>meniscus a curve at a liquid's surface by which one measures the volume of a liquid</p>	<p>volume a measure of the size of a body or region in three-dimensional space</p> <p>weight a measure of the gravitational force exerted on an object; its value can change with the location of the object in the universe</p>
--	--

1. Describe Why is an apple an example of matter?

2. Explain What is the difference between mass and weight?

3. Identify In the figure below, what is the volume of water in the graduated cylinder?

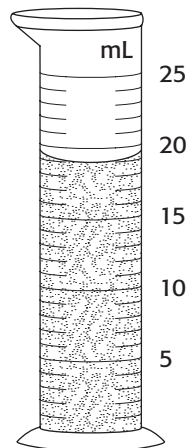

4. Determine A rock is placed into a graduated cylinder containing 80 mL of water. What is the volume of the rock if the water level rises to the 120 mL mark?

5. Calculate One airline limits the size of carry-on luggage to a volume of 40,000 cm³. A passenger has a carry-on that has an area of 1,960 cm² and is 23 cm high. Is the passenger's luggage OK to carry onto the airplane? Show your work.

SECTION 2 **Physical Properties**



California Science Standards

8.7.c, 8.8.a, 8.8.b, 8.8.d

BEFORE YOU READ

After you read this section, you should be able to answer these questions:

- What are the physical properties of matter?
- What is density?
- What is a physical change of matter?
- What makes objects float or sink?

STUDY TIP

Increase Vocabulary Read this section silently. Underline all the words that are new to you.

READING CHECK

1. Describe What are physical properties?

What Are the Physical Properties of Matter?

We use one or more of our senses to identify an object. The properties we are sensing are the physical properties of the object. A **physical property** of matter can be detected and measured without making a new substance. If a new substance is made, a chemical property has been measured. Here we will consider only physical properties. ✓

There are many physical properties that can help you identify an object. Examples of physical properties include color, odor, texture, and shape. How would you identify a fruit as an apple? You would probably first look at its color and shape. Its odor, and certainly its taste, would help confirm that the fruit was an apple.

The physical properties of an object may also include its strength, flexibility, ability to conduct electricity, and magnetism. Some other important physical properties of matter are listed in the table below.

Physical property	Description
Thermal conductivity	how heat moves through a substance
Ductility	the ability of a substance to be pulled into a wire shape
State	the physical form of matter (solid, liquid, or gas)
Malleability	the ability of a substance to be rolled into a shape
Solubility	the ability of a substance to dissolve
Density	how compact a substance is
Compressibility	the ability of a substance to be squeezed or pressed together

Critical Thinking

2. Apply Concepts You are given two balls that are made from the same rubber. They are also the same size and color. One is hollow and one is solid. Give three physical properties that can be used to identify the ball that is solid.

SECTION 2 Physical Properties *continued***DENSITY**

Density is a physical property of matter that describes how its mass and volume are related. **Density** is a measure of the amount of matter in a given volume. For example, a golf ball and table-tennis ball have similar volumes, so they occupy about the same amount of space. However, since the golf ball has more mass, it has a greater density than the table-tennis ball does. ✓

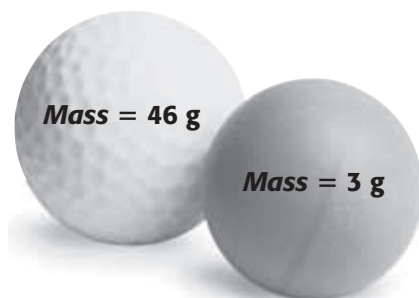

A golf ball is denser than a table-tennis ball because the golf ball contains more matter in a similar volume.

To find an object's density (D), you measure its mass (m) and volume (V) and then use the following formula:

$$D = \frac{m}{V}$$

The units of density are the results of a mass unit (kg or g) being divided by a volume unit (L, mL, or cm^3). For example, one density unit for solids is grams per cubic centimeter (g/cm^3), and one density unit for liquids is grams per milliliter (g/mL).

A substance's density does not depend on how much of the substance there is. Generally, in the same room at the same time, a lot of something or a little of it will have the same density. For example, 1 kg of solid iron will have the same density as 1 g of solid iron.

How Is Density Determined?

You can solve a density problem by taking the following steps:

1. Write the density equation, $D = m \div V$.
2. Replace m and V with the measurements given in the problem, and then solve for D .

For example, what is the density of mercury if 270 g of mercury has a volume of 20 mL?

$$D = m \div V$$

$$D = 270 \text{ g} \div 20 \text{ mL} = 13.5 \text{ g/mL}$$

 **READING CHECK**

3. Describe What is density a measure of?

Math Focus

4. Determine How much more matter is in a golf ball than in a table-tennis ball?

 **CALIFORNIA STANDARDS CHECK**

8.8.b Students know how to calculate the density of substances (regular and irregular solids and liquids) from measurements of mass and volume.

5. Calculate A nugget of gold that has a mass of 28 g (1 oz) has a volume of 1.45 cm^3 . What is its density? Show your work.

SECTION 2 Physical Properties *continued*

READING CHECK

6. Describe Under what conditions is the density of a substance always the same?

TAKE A LOOK

7. Identify You are given an unknown solid with a density of about 7 g/cm³. Which solid is it?

USING DENSITY TO IDENTIFY SUBSTANCES

Density is a useful physical property. At the same temperature and pressure, the density of a substance is always the same. So, density can be used to help identify an unknown substance. ✓

The densities of some common substances are given in the table below.

Densities of Common Substances at 20°C and 1 atm			
Substance	Density (g/cm ³)	Substance	Density (g/cm ³)
Helium (gas)	0.000166	Zinc (solid)	7.13
Oxygen (gas)	0.00133	Silver (solid)	10.5
Water (liquid)	1.00	Lead (solid)	11.4
Pyrite (solid)	5.02	Mercury (liquid)	13.5

DENSITY OF SOLIDS

Would you rather carry around 1 kg of lead or 1 kg of feathers? They have the same mass, but they are very different. Lead is much denser than feathers. A 1 kg mass of lead has about the same volume as a stick of butter. A 1 kg mass of feathers would take up about the same space as a pillow. The difference in volume makes the lead easier to carry.

DENSITY, FLOATING, AND SINKING

If you know the density of a substance, you can tell if it will float or sink. For example, if the density of an object is less than the density of water, the object will float in water. Cork, many types of wood, and some plastics are less dense than water. That is why they float in it.

If the density of an object is greater than the density of water, it will sink in water. Rock and many types of metal are denser than water, so they sink. ✓

The figure below shows a can of diet soda and a can of regular soda in a tank of water. You can see that their densities are different.

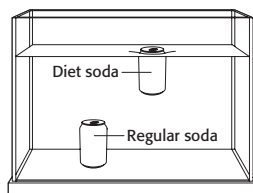

In a tank of water, a can of diet soda floats, and a can of regular soda sinks.

READING CHECK

8. Describe When will an object sink in water?

Critical Thinking

9. Apply Concepts Which can of soda in the drawing is less dense than water? How do you know?

SECTION 2 Physical Properties *continued*

Take a look at the following figure. It shows different kinds of liquids in a graduated cylinder. What do you think causes them to look that way? Each of the liquids (maple syrup, water, and corn oil) has a different density. When these three liquids are carefully poured into the cylinder, they form three different layers.

This happens because their densities are different. The liquid that is most dense is in the bottom layer, and the liquid that is least dense is on the top. ✓

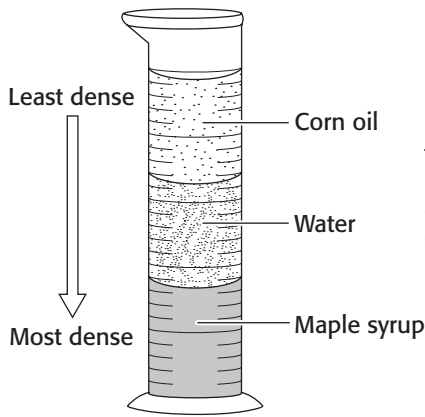

This graduated cylinder contains three liquids that form three layers because of their densities. The layers are in order of increasing density from top to bottom.

READING CHECK

10. Identify Several liquids are poured into a container. They do not mix or dissolve in one another. What must be true of the liquid in the top layer?

What Is a Physical Change?

Any change that affects the physical properties of a substance is a **physical change**. Imagine that a piece of silver is pounded into a heart-shaped charm. This is a physical change because only the shape of the silver has changed. The piece of silver is still silver. Take a look at the figure below to see some other examples of physical changes. ✓

A change from a solid to a liquid is a physical change. All changes of state are physical changes.



This aluminum can has gone through the physical change of being crushed. The identity of the can has not changed.



READING CHECK

11. Describe What is a physical change?

TAKE A LOOK

12. Identify Name the physical change that happened to the popsicle.

SECTION 2 Physical Properties *continued***EXAMPLES OF PHYSICAL CHANGES**

When a substance changes from a solid to a liquid, it is said to have changed state. Solid, liquid, and gas are the three states of matter. Any change in state is a physical change. ✓

READING CHECK

13. Identify When a liquid changes into a gas, what kind of physical change occurs?

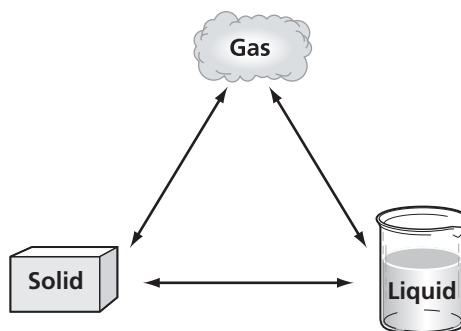

When you freeze water to make ice, you cause a physical change. Heating water in a teapot makes steam. This is also a physical change. Sugar seems to disappear or dissolve in water. However, if the water evaporates, the sugar reappears, so dissolving is a physical change.

REVERSIBILITY OF PHYSICAL CHANGES

In the figure above, the arrows each have two heads. This means that each change can be reversed. A solid can change into a liquid and then back into a solid. ✓

READING CHECK

14. Identify What change or changes of state can happen to a gas? Looking at the figure may help you with the answer.

READING CHECK

15. Identify What happens to the identity of a substance when it makes a physical change?

MATTER AND PHYSICAL CHANGES

Physical changes do not change the identity of matter. Melting, changing from liquid to gas, changing from liquid to solid, and changing shape are all examples of physical change. Physical changes can often be reversed easily, and the identity of the substance itself never changes. ✓

Section 2 Review

8.7.c, 8.8.a, 8.8.b, 8.8.d



SECTION VOCABULARY

density the ratio of the mass of a substance to the volume of the substance

physical change a change of matter from one form to another without a change in chemical properties

physical property a characteristic of a substance that does not involve a chemical change, such as density, color, or hardness

1. Describe In words, explain how to calculate the density of a substance.

Use this table to answer questions 2 and 3.

Substance	Density (g/cm ³)
Wood (oak)	0.85
Water	1.00
Ice cube	0.93
Aluminum	2.7
Lead	11.3
Gold	19.3
Ethanol	0.94
Methanol	0.79

2. Identify Will any of the other substances in the table float in methanol? Why?

3. Identify Which substance would have a mass of 135 g when it has a volume of 50 cm³? Show your work.

$$D = \frac{m}{V}$$

4. Identify Two balls have the same mass, but one has a larger volume than the other. Which ball has the larger density?

5. Explain Most substances become more dense when they freeze. However, when water freezes, it becomes less dense. What must happen for this to be true? Hint: The mass stays the same.

CHAPTER 3 Properties of Matter

SECTION

3

Chemical Properties



California Science Standards

8.5.a, 8.5.c, 8.5.d

BEFORE YOU READ

After you read this section, you should be able to answer these questions:

- What are chemical properties of matter?
- What is a chemical change?
- What is the effect of a chemical change?

STUDY TIP

Compare Make a table with two columns: Chemical property and Physical property. List the chemical and physical properties that are discussed in this section.

**READING CHECK**

1. Fill In Chemical properties of matter describe matter based on its ability to

**CALIFORNIA STANDARDS CHECK**

8.5.a Students know reactant atoms and molecules interact to form products with different chemical properties.

Word Help: interact to act upon one another

2. Compare In a chemical reaction, how do the chemical properties of the products compare with the chemical properties of the reactants?

What Are the Chemical Properties of Matter?

Physical properties are not the only properties that describe matter. **Chemical properties** describe the ability of matter to change into new matter. One chemical property of matter is reactivity. *Reactivity* is the ability of a substance to change into a new substance.

One kind of reactivity is flammability. *Flammability* is the ability of a substance to burn. For example, wood has the chemical property of flammability. You may have seen the result of wood burning in a fireplace or in a campfire. ✓

When wood burns, it becomes several different substances. Ash and smoke are just two of these new substances. The properties of the new substances are different from the original properties of the wood. Ash and smoke cannot burn. Unlike wood, they have the chemical property of nonflammability.

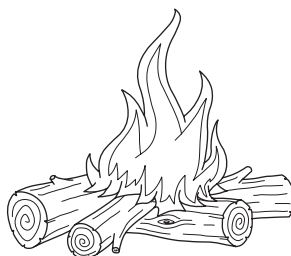

Wood burning in a fire



Ashes after the wood has burned

Rusting is another chemical property. Only iron can rust. Iron rusts when it combines with oxygen to form a new substance called iron oxide.

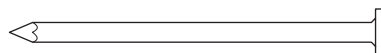

Iron nail with no rust



Iron nail with rust

SECTION 3 Chemical Properties *continued***COMPARING PHYSICAL AND CHEMICAL PROPERTIES**

How can you tell the difference between a physical property and a chemical property? A physical property can be seen or identified because it does not change the identity of a substance. A physical change occurs when silver is pounded or gold is melted to make jewelry. After the change, the silver is still silver and the gold is still gold.

The chemical properties of a substance can't be seen unless you change the identity of the substance. For example, you may not know whether a liquid is flammable until you try to light it. If it burns, it has the chemical property of flammability. However, burning has changed the liquid into new substances.

A substance always has chemical properties. A piece of wood is flammable even when it is not burning. Iron can form rust even though it has not rusted.

CHARACTERISTIC PROPERTIES

The properties that are most useful in identifying a substance are called *characteristic properties*. These properties are constant. This means that they do not change. The characteristic properties of a substance can be physical, chemical, or both.

A piece of iron has characteristic properties that help identify it as iron. A good example of this is density. Iron always has the same density when measured at the same temperature and pressure. Iron also rusts.

Scientists can identify a substance by studying its physical and chemical properties. The table below shows some characteristic properties of several liquids.

Property	Rubbing alcohol	Kerosene	Gasoline
Density (g/cm ³)	0.8	0.8	0.8
Ability to dissolve, or mix with water	yes	no	no
Flash point (°C) (The higher the flash point, the more flammable the liquid.)	12	40	-40

Critical Thinking

3. Compare Describe what happens to a substance when a physical property and a chemical property of the substance are observed.

Critical Thinking

4. Apply Concepts A scientist measures three properties of a liquid. Its density is 0.8 g/cm³, it does not mix with water, and its flash point is -40°C. Using the table to the right, find the identity of the substance. Explain your answer.

SECTION 3 Chemical Properties *continued*

What Happens During a Chemical Change?

When a substance changes into one or more new substances that have new and different properties, a **chemical change** has happened. Chemical changes are not the same as chemical properties. The chemical properties of a substance describe which chemical change can happen to the substance. For example, flammability is a chemical property. Burning is the chemical change that shows this property. ✓

A chemical change is the process that causes a substance to change into a new substance. You can learn about a substance’s chemical properties by observing what chemical changes happen to that substance.

Chemical changes occur more often than you think. For example, a chemical change happens every time you use a battery. Chemical changes also take place within your body when the food you eat is digested. The figure below describes other chemical changes.

READING CHECK

5. Describe What is a chemical change?

TAKE A LOOK

6. Identify What property of milk told the girl that the milk had soured?



Soured milk smells bad because bacteria have formed smelly new substances in it.



The **Statue of Liberty** is made of copper, which is orange-brown. But this copper is green because of its interactions with moist air. These interactions are chemical changes that form copper compounds. Over time, the compounds turn the statue green.

A fun way to see what happens during a chemical change is to bake a cake. A cake recipe combines different substances. Eggs, cake mix, oil, and water are mixed to form a batter. When the batter is baked, you end up with a substance that is very different from the original batter.

The heat of the oven and the mixture of ingredients cause a chemical change. The result is a cake. The cake has properties that are different from the properties of the raw ingredients alone.

Critical Thinking

7. Apply Concepts How do you know that baking a cake causes a chemical change?

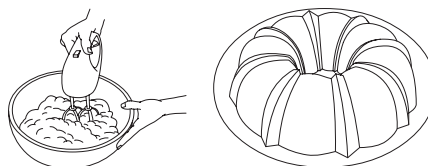

Cake mix batter becomes a cake.

SECTION 3 Chemical Properties *continued***SIGNS OF CHEMICAL CHANGES**

A change in color, odor, or texture may show that a chemical change has happened. Many chemical changes produce or absorb heat.

An increase in temperature happens when a chemical change releases, or gives off, heat. Wood burning is a good example of a chemical change that gives off heat.

Some chemical changes cause a substance to absorb, or gain, heat. Sugar is broken down into carbon and water when it is heated. ✓

MATTER AND CHEMICAL CHANGES

When matter has a chemical change, the identity of the matter changes. Chemical changes can be reversed only by other chemical changes. For example, water can be made by heating a mixture of hydrogen and oxygen. Hydrogen and oxygen are produced when an electric current is passed through water. The electric current supplies the energy needed to pull the hydrogen away from the oxygen.

PHYSICAL VERSUS CHEMICAL CHANGES

Sometimes it is hard to decide whether a physical change or a chemical change has happened to an object. Ask yourself whether something new formed as a result of the change?

Physical changes do not change the matter that makes up an object. Ice melts into water and water freezes into ice. The water does not change in the process. The only changes that happened were to its physical properties.

Chemical changes change the matter that makes up a substance. A chemical change would change water into another substance. ✓

REVERSING CHANGES

Many physical changes, like freezing, melting, and boiling, can be reversed easily. Remember that the substance does not become another substance.

This is very different from a chemical change. During a chemical change, the substance does become another substance. Many chemical changes cannot be reversed easily. For example, ashes and smoke cannot be unburned to make wood.

 **READING CHECK**

8. Identify What are four changes that indicate that a chemical change has occurred?

 **READING CHECK**

9. Describe How can you tell that a physical rather than a chemical change has occurred?

Section 3 Review

8.5.a, 8.5.c, 8.5.d



SECTION VOCABULARY

chemical change a change that occurs when one or more substances change into entirely new substances with new chemical properties

chemical property a property of matter that describes a substance's ability to participate in chemical reactions

1. Describe How is a chemical property different from a chemical change?

2. Explain Why is reactivity not a physical property?

3. Identify What can be absorbed or produced as the result of a chemical reaction?

4. Complete Fill in the type of change for each description in the table below.

Type of change	Description of change
	rusting
	boiling
	freezing
	burning

5. Identify What are four things that indicate that a chemical change probably happened?

6. Identify and Explain Originally, the Statue of Liberty was copper colored. After many years, it turned green. What kind of change happened? Explain your answer.

7. Identify A burning candle is observed. Heat is felt above the flame, black smoke is seen rising from the wick, and wax melts. What caused each change?

Four States of Matter

BEFORE YOU READ

After you read this section, you should be able to answer these questions:

- What is matter made of?
- What are the three most common states of matter?
- How do particles behave in each state of matter?



California Science Standards

8.3.d, 8.3.e

What Are the Four States of Matter?

Have you ever had a steaming bowl of soup and an ice cold drink for lunch? The three most common states of matter are found in this lunch. The soup and the ice cold drink both contain water. However, the water exists in three different forms. The soup and drink are *liquids*. The ice is a *solid*. The soup's smell is carried to your nose along with water vapor, a *gas*.

The **states of matter** are the physical forms that substances take. Solids, liquids, and gases are the most common states, or forms, of matter. There is also a fourth state of matter, known as *plasma*. ✓

Matter is made up of very tiny particles. These particles are called *atoms* and *molecules*. Atoms and molecules behave differently in each state of matter. Atoms and molecules are always in motion, but their motion depends on the state. The particles can only vibrate in the solid state. In the liquid state, the particles can slide past each other. The particles of a gas are free to move anywhere.

The figure below describes three states of matter and how particles behave in each.

Models of a Solid, a Liquid, and a Gas



Particles of a solid have a strong attraction between them. The particles are closely locked in position and only vibrate.



Particles of a liquid are more loosely connected than those of a solid and can move past one another.



Particles of a gas move fast enough that they overcome the attractions between them. The particles move independently and collide frequently.

STUDY TIP

Clarify Concepts Take turns reading this section out loud with a partner. Stop to discuss ideas that seem confusing.

READING CHECK

1. Identify What are the four states of matter?

TAKE A LOOK

2. Identify In which state do the particles move about the most? In which state do they move about the least?

SECTION 1 Four States of Matter *continued*

What Are the Properties of Solids?

Any solid material, such as a penny, a rock, or a marble, has a definite shape and volume. For example, if you place any of these solid objects into a bottle, its shape and volume will stay the same. All of these objects keep their original shape and volume no matter where they are placed. A **solid** is the state of matter that has a definite shape and volume.

The particles of a solid are very close together. They have a strong attraction to one another. So, the particles of a solid are locked in place. However, they do vibrate (or shake). Remember, the particles of any substance are always in motion. ✓

READING CHECK

3. Explain Why can't the particles of a solid move away from one another?

READING CHECK

4. Describe What can the particles of a liquid do that the particles of a solid can't do?

TAKE A LOOK

5. Identify When fruit juice is poured into different containers, what changes? What stays the same?

What Are the Properties of Liquids?

Although an ice cube and liquid water are both made up of the same material, they are physically very different. In solids, particles are closely locked together and vibrate in place. In liquids, particles are able to move more freely.

A **liquid** is a substance that has a definite volume but no definite shape. For example, a liter of milk takes on the shape of its container. The same liter of milk will take on the shape of a bowl it is poured into. Only the shape of the milk changes. The volume of the milk stays the same.

The particles move fast enough in a liquid to overcome their attraction to one another. They can move or slide past one another, but they always stay close together. We know that the particles in liquids can move past one another because liquids can change shape. ✓

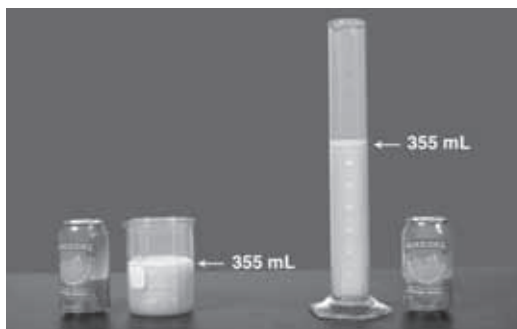

Although their shapes are different, the beaker and the graduated cylinder each contain 355 mL of juice.

SECTION 1 Four States of Matter *continued*

What Are the Properties of Gases?

The properties of a gas are different from the properties of other states of matter. A **gas** is a state of matter that has no definite shape or volume. Any gas will fill, or take on the shape of, any container it is in. This is because gas particles have little attraction to one another.

A gas that may be familiar to you is helium. Helium is the gas that is used to fill birthday balloons. A small tank of helium can fill many balloons. As helium particles are put into a balloon, they move to fill the volume of the balloon. The changes in the shape and volume of a gas happen because gas particles move about freely. The amount of empty space between them can change.

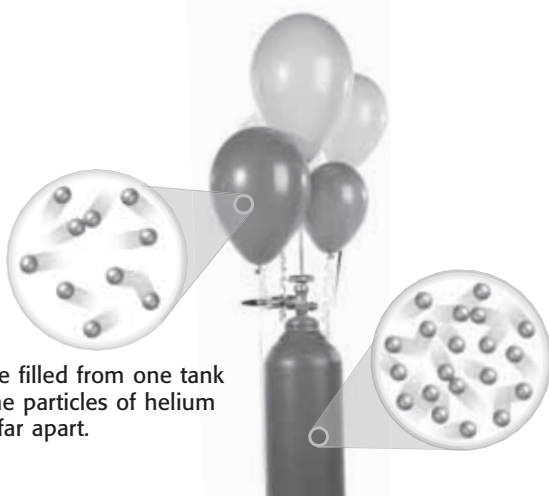

Many balloons can be filled from one tank of helium because the particles of helium gas in a balloon are far apart.

	CALIFORNIA STANDARDS CHECK
<p>8.3.d Students know the states of matter (solid, liquid, gas) depend on molecular motion.</p>	
<p>6. Compare How does the motion of the particles change when water changes from a solid to a liquid to a gas?</p>	
<p>_____</p> <p>_____</p> <p>_____</p>	

TAKE A LOOK

7. Identify Where are the particles of helium farthest apart, in the tank or in the balloon?

What Is Plasma?

Most people can name only the three most common states of matter. The fourth state of matter is plasma. It is the most common state of matter in the universe. The sun and other stars are made of plasma. Plasma is similar to gas because it has no definite shape or volume. However, **plasmas** consist of ions and free-moving electrons. Other states of matter consist of neutral atoms and molecules.

An example of plasma is in a glowing neon sign. Neon is a gas that is often found in the light tube of a sign. When the switch is turned on, electrons are ripped from the neon atoms. This makes ions and free electrons. So, turning on the sign changes neon gas into a plasma.

On Earth, natural plasmas can be found in lightning and in fires. Artificial plasmas are found in glowing fluorescent lights and neon signs.

Critical Thinking

8. Infer A fluorescent light works like a neon sign. What happens to the gas inside a fluorescent light when it is switched on?

Section 1 Review

8.3.d, 8.3.e



SECTION VOCABULARY

gas a form of matter that does not have a definite volume or shape

liquid the state of matter that has a definite volume but not a definite shape

plasma in physical science, a state of matter that starts as a gas and then becomes ionized; it consists of free-moving ions and electrons, it takes on an electric charge, and its properties differ from the properties of a solid, liquid, or gas

solid the state of matter in which the volume and shape of a substance are fixed

states of matter the physical forms of matter, which include solid, liquid, and gas

1. Identify What are you and all the matter around you made of?

2. Identify Name the four states of matter, and give an example of each.

3. Compare What can the particles of a liquid do that the particles of a solid can't do?

4. Compare What can the particles of a gas do that the particles of a liquid can't do?

5. Describe Complete the following table to show how states of matter differ from one another.

State of matter	Definite shape	Definite volume	Type of particles present
Solid			atoms, molecules
Liquid	no		
Gas		no	
Plasma			

CHAPTER 4 States of Matter

SECTION

2

Changes of State

BEFORE YOU READ

After you read this section, you should be able to answer these questions:

- What is a change of state?
- What are the changes that matter can undergo?
- How are changes of state related to energy and temperature?



California Science Standards

8.3.d, 8.3.e, 8.5.d, 8.7.c

How Are Changes of State and Energy Related?

It can be tricky to eat a frozen juice bar outside on a hot day. In just minutes, the juice bar begins to melt. As it melts, the juice bar changes state from a solid to a liquid. A **change of state** happens when matter changes from one physical form to another. A change of state is always a physical change. Remember that in a physical change, the identity of the substance does not change.

Energy must be added or removed in order for a substance to change its physical state. Particles of different substances move differently. This movement of particles depends on the state of the substance (solid, liquid, or gas). ✓

For example, the particles in frozen water, or ice (a solid), only vibrate. The particles in liquid water move faster and have more energy than particles in ice. To change ice into liquid water, energy must be added. To change liquid water into ice, energy must be removed.

The figure below shows the possible changes of state for water.

Changes of state involving water are shown here. What two steps would the solid need to go through to change into a gas?

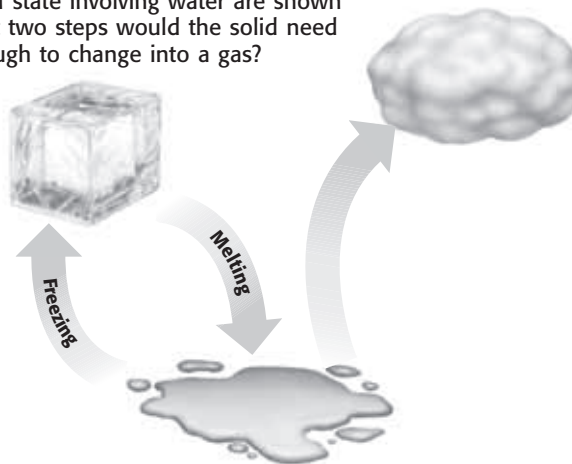

STUDY TIP

Organize As you read the chapter, complete a table with the following headings:

- name of change
- change that occurs
- energy (added or removed)

READING CHECK

1. Identify What must be added or removed for a substance to undergo a change of state?

TAKE A LOOK

2. Describe What happens to water in a puddle before it forms droplets of liquid water in a cloud?

SECTION 2 Changes of State *continued***CALIFORNIA STANDARDS CHECK**

8.5.d Students know physical processes include freezing and boiling, in which a material changes form with no chemical reaction.

3. Identify What kind of change occurs when a substance melts?

What Is Melting?

When energy is added to a solid, it can melt. **Melting** is the change of state from a solid to a liquid. For example, an ice cube in a glass of lemonade melts as it absorbs heat from the lemonade.

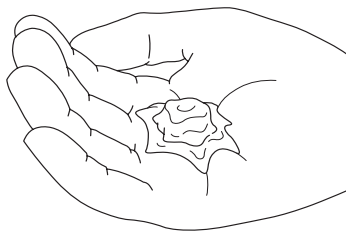

Gallium is a metal that can melt in your hand. Even though gallium is a metal, it would not be very useful as jewelry!

MELTING POINT AND ENERGY

The *melting point* of the substance is the temperature at which it changes from a solid to a liquid. As the temperature of the solid becomes greater, its particles move faster. When a certain temperature is reached, the solid will melt. The melting point of a substance is a physical property of the substance.

Melting point depends on the composition, or makeup, of the substance. It can be used to help identify a substance. For example, copper has a melting point of 420.7°C . You can tell that a substance that looks like copper is not really copper if it does not melt at 420.7°C .

For a solid to melt, particles must absorb energy. The particles move faster and have less attraction to one another. This allows the particles to flow, or move past one another. The solid melts and becomes a liquid. ✓

What Are Freezing and Freezing Point?

The *freezing point* is the temperature at which a substance changes from a liquid to a solid state. When a liquid freezes, its particles have less energy and become closely locked in position. Energy is removed from the substance during freezing.

Freezing is the exact opposite of melting. The freezing point of a substance is exactly the same as the melting point of the substance. They both happen at the same temperature. For example, liquid water freezes and becomes solid ice at temperatures below 0°C . Solid ice melts and becomes liquid water at temperatures above 0°C . ✓

READING CHECK

4. Describe What do the particles of a liquid do that particles of a solid don't do?

READING CHECK

5. Identify If the freezing point of a substance is 68°C , what is its melting point?

SECTION 2 Changes of State *continued*

What Is the Process of Evaporation?

When you get out of a swimming pool on a windy day, your body sometimes feels cold. Why? The water on your skin is evaporating. **Evaporation** is the change of state from the liquid state to the gas state. The reason you feel cold is because evaporation requires energy. The energy in this case goes from your body into the liquid water. The liquid water changes state to a gas called *water vapor*.

This change of state also happens when you sweat. Sweat is mostly water. When sweat appears on your skin, the water absorbs heat (energy) from your skin. This causes the water to evaporate, and you feel cooler. ✓

EVAPORATION AND BOILING

Evaporation can occur at low temperatures. In fact, water can evaporate at temperatures near its freezing point. However, at low temperatures, the water does not evaporate quickly. For water to evaporate quickly in an open container, it must be heated. If the water is heated to a high enough temperature, it will boil.

Boiling occurs when a liquid evaporates quickly. The particles leave the liquid state and change to particles of vapor, or gas. This change creates a vapor pressure. When a liquid is boiling, the vapor pressure equals the air pressure in the room. The temperature at which boiling occurs is known as the *boiling point* of the substance.

Like the melting point, the boiling point can help identify a substance. For example, the normal boiling point of water is about 100°C. Many liquids that look like water boil at different temperatures.

The figure below shows water evaporating at room temperature and water boiling.

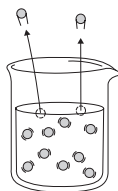

Evaporation can happen in a liquid below its boiling point. Some particles at the surface of the liquid move fast enough to break away from the particles around them. When they break away, they become a gas (or vapor).

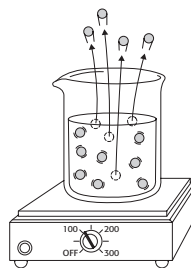

Boiling happens in a liquid at its boiling point. As energy is added to the liquid, particles throughout the liquid move faster. When they move fast enough to break away from other particles, they evaporate. The bubbles you see when water boils contain water vapor.



Say It

Investigate People usually feel warmer on a warm, humid day than on a warm, dry day. Try to find out why, and report to the class.

READING CHECK

6. Describe Why does sweating help cool your body?

Math Focus

7. Calculate What is the difference between the freezing point and boiling point of water? What is the difference between the freezing point and melting point of water?

TAKE A LOOK

8. Identify Are there more water vapor molecules above a beaker of water at room temperature or a beaker of water at its boiling point?

SECTION 2 Changes of State *continued*

Critical Thinking

9. Describe How does water from a lake become part of a cloud in the sky?

 **READING CHECK**

10. Identify Which process requires energy, condensation or evaporation?

What Is the Process of Condensation?

On a hot day in the summer, a glass of ice water looks as if it is sweating. The water drops that are seen on the outside of the glass form because of condensation.

Condensation is the change of state from a gas to a liquid. The water vapor in the air (sometimes called humidity) hits the cold glass. The particles of water vapor lose energy and change into the liquid state.

Condensation happens when a gas is cooled. As the gas cools, the particles lose energy, move more slowly, and have a greater attraction for one another. The particles begin to clump together. They change to the liquid state. Condensation and evaporation are the opposite of each other. For evaporation to occur, the particles of a liquid must gain energy, move faster, and change to the gas state.

The *condensation point* of a substance is the temperature at which a gas becomes a liquid. Under most conditions, the condensation point of a substance is the same temperature as the boiling point of the substance. Condensation can occur when the temperature of a surface is below the condensation point of the gas.

For example, water droplets form a haze on a bathroom mirror when you take a shower. The water droplets condense from the water vapor in the air. The mirror is at a temperature well below water vapor's condensation point, 100°C.

Take a close look at the spider web in the figure below. Notice the beads of water that have formed on it. This happened because water vapor condensed on the web from gas to liquid water.

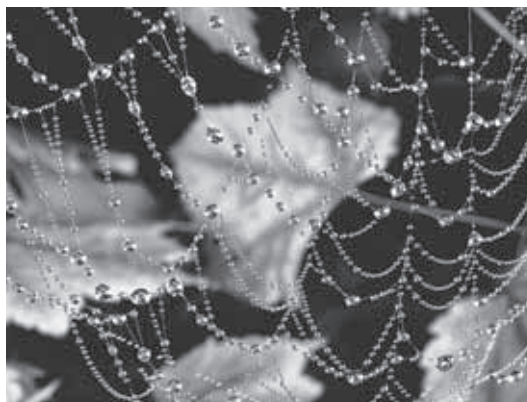

Beads of water form when water vapor in the air contacts a cool surface, such as this spider web.

Critical Thinking

11. Explain As the day gets warmer, the water droplets on a spider web are no longer seen. Why?

SECTION 2 Changes of State *continued*

What Is the Process of Sublimation?

The electric company in your community may sometimes hand out dry ice when a storm knocks out power. Dry ice keeps groceries cold, but it does not melt, as ice does. Dry ice can change directly from a solid state to a gas state. This process is known as **sublimation**. ✓

Dry ice is frozen carbon dioxide. Its temperature is -78.5°C or lower. When it sublimates, it pulls energy from substances around it. This makes substances around it become cold. The energy it pulls weakens the attraction of the particles in the solid dry ice. When the attraction weakens enough, the solid changes into a gas. It does not melt into a liquid.

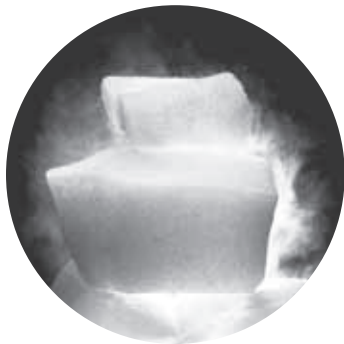

Dry ice is a substance that will change directly from a solid to a gas at atmospheric pressure.

✓ **READING CHECK**

12. Describe What occurs when a substance sublimates?

 **Say It**

Investigate Put an ice cube in the freezer compartment of a refrigerator. Allow it to sit, undisturbed, for about two weeks. Report to the class on how its size changes.

How Are Changes of State and Temperature Related?

Two things can happen to a substance when it gains or loses energy. Either the temperature of the substance changes, or the state of the substance changes. When temperature changes, the speed of the particles that make up the substance also changes. During a change of state, the temperature of a substance does not change. It will change only after the change of state is complete.

Take a close look at the figure below. The figure shows the effects and state changes that happen when energy is added to ice.

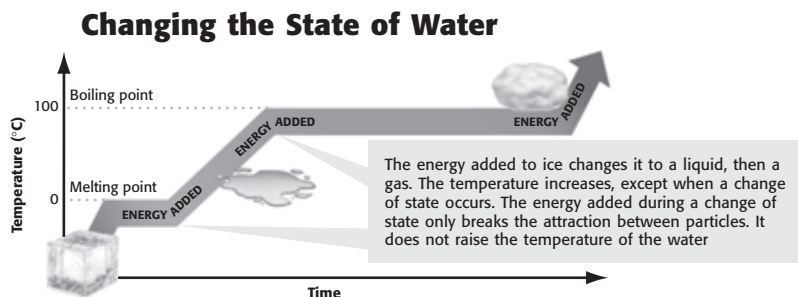

TAKE A LOOK

13. Describe What is the shape of the graph at the melting and freezing points of water? What does this shape tell you about the temperature?

Section 2 Review

8.3.d, 8.3.e, 8.5.d, 8.7.c



SECTION VOCABULARY

boiling the conversion of a liquid to a vapor when the vapor pressure of the liquid equals the atmospheric pressure

change of state the change of a substance from one physical state to another

condensation the change of state from a gas to a liquid

evaporation the change of state from a liquid to a gas

Wordwise The prefix e- means “out” or “from.”

The root *vapor* means “gaseous form of any substance that is usually a liquid or solid.”

melting the change of state by which a solid becomes a liquid by adding heat

sublimation the process in which a solid changes directly into a gas

1. Compare How do the states of matter differ in terms of motions of their particles?

2. Describe In terms of energy, what happens during a change of state? Why is it a physical change?

3. Compare What is the difference between freezing and melting? How are they similar?

4. Explain How are evaporation and boiling the same? How do they differ?

5. Describe What is needed for a solid to sublime, and what change of state occurs?

6. Complete Fill in the missing boxes in the table below.

Property	Solid	Liquid	Gas
Attraction between particles		weaker than in a solid	
How close the particles are	close	close	
Movement of particles		movement past one another	

CHAPTER 5 Elements, Compounds, and Mixtures

SECTION

1

Elements

BEFORE YOU READ

After you read this section, you should be able to answer these questions:

- What is an element?
- How do elements differ from other materials?
- How are elements classified?



California Science
Standards

8.7.c

What Are Elements?

Many materials can be broken down into different components. For example, some rocks contain copper. When they are heated in a large furnace, the copper separates from the rest of the rock. Another example is the breakdown of water when electricity is passed through it. The electric current causes hydrogen and oxygen gases to form.

Some materials cannot be separated or broken down into other materials. An **element** is a pure substance that cannot be separated into simpler substances by chemical or physical methods. This is how elements are different from all other materials.

A **pure substance** is a material in which all of the basic particles are identical. All of the particles of a pure substance are alike, no matter where the substance is found. Pure substances that are not elements can be broken down into simpler substances. ✓

The basic particles of an element are called *atoms*. Copper is an example of an element. All of the atoms in a piece of pure copper are alike. As shown in the figure below, iron is also an element.

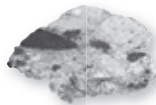

The atoms of iron in the meteorite from space are identical to the atoms of iron in a steel spoon. There are also atoms of iron in the cereal, in the boy's braces, and even in his blood.



Organize In your notebook, make a concept map, using the terms *element*, *substance*, *metal*, *nonmetal*, and *metalloid*.



1. Compare How do elements differ from other pure substances?

TAKE A LOOK

2. Identify Look at the illustration, and identify one source of iron that comes to Earth from somewhere else.

SECTION 1 Elements *continued*

How Can Elements Be Classified?

Elements can be classified based on their properties. There are two types of properties, chemical and physical. Characteristic physical properties include hardness, melting point, and density. Chemical properties include reactivity and flammability. ✓

Two elements may have a particular property in common, but you can use other properties to tell them apart. For example, the elements helium and krypton are both colorless, odorless, unreactive gases. However, these elements have different densities (mass per unit volume). Helium is less dense than air, so a helium balloon floats upward. A krypton-filled balloon, on the other hand, would sink to the floor. Krypton is denser than air.

READING CHECK

3. List What are three physical properties that are characteristics of an element?

Critical Thinking

4. Make Inferences

Compare the properties of iron with those of cobalt and nickel. How do you think cobalt and nickel are used in manufactured products?

Unique Properties of Elements

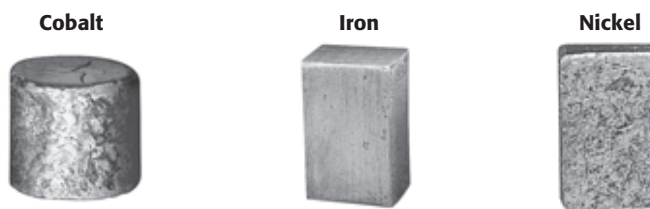

- | | | |
|---|---|---|
| <ul style="list-style-type: none"> • Melting point: 1,495°C • Density: 8.9 g/cm³ • Conducts electricity and heat. • Reactivity: Does not react with oxygen in the air. | <ul style="list-style-type: none"> • Melting point: 1,535°C • Density: 7.9 g/cm³ • Conducts electricity and heat. • Reactivity: Reacts by combining with oxygen in the air to form rust. | <ul style="list-style-type: none"> • Melting point: 1,455°C • Density: 8.9 g/cm³ • Conducts electricity and heat. • Reactivity: does not react with oxygen in the air. |
|---|---|---|

The figure above shows some of the properties of three different elements. The physical properties shown are melting point, electrical and thermal conductivities, and density. Each element has other physical properties, as well, including color, hardness, and texture. The figure also includes a chemical property—the reactivity of the element with oxygen in the air.

If you had a piece of metal, could you determine which of the elements it was, based on these properties? Iron can be distinguished from both other elements by physical and chemical properties. The density of iron is much less than that of either cobalt or nickel, and it reacts with oxygen in the air.

You can't use those properties to tell nickel and cobalt apart. However, their melting points differ by 40°C. So, you can use melting points to tell them apart. ✓

READING CHECK

5. Explain Why can't you use the density or reactivity with air to determine whether a sample is cobalt or nickel?

SECTION 1 Elements *continued***How Can Elements Be Sorted?**

Think about all the different types of dogs that you have seen. Dogs can be classified based on different properties. These include size, ear shape, and length of coat. You can often determine a dog's breed just with a quick glance. The figure below shows three kinds of terriers. They are not exactly alike, but they share some properties.



Even though these dogs are different breeds, they have enough in common to be classified as terriers.

The elements can be sorted based on properties, just as the dogs in the illustration can. There are three major categories of elements: metals, nonmetals, and metalloids. The elements iron, cobalt, and nickel are all metals. They are not exactly alike, but they have similar properties. ✓

Metals tend to be shiny solids (except mercury, which is a shiny liquid). Metals conduct heat and electric current well. **Nonmetals** do not conduct heat or electric current very well. Many nonmetals are gases. The solid nonmetals have a dull appearance. **Metalloids** have some of the properties of metals and some of the properties of nonmetals. Metalloids are important in electronics because their electrical conductivity can vary with conditions.

Three Major Categories of Elements			
Property	Metals	Nonmetals	Metalloids
Appearance	shiny	dull	some shiny
Conductivity of heat and electricity	good	poor	some good
Malleability—ability to be hammered into sheets	malleable	not malleable	some somewhat malleable
Ductility—ability to be made into wires	ductile	not ductile	some somewhat ductile
Brittleness	not brittle	brittle	some brittle

TAKE A LOOK

6. Describe What are some of the physical properties that describe terriers?

READING CHECK

7. Identify What are the three main categories of elements?

 **Say It**

Explore Applications The properties of metals make them very useful in everyday things. In groups of three or four, make a list of things that you use for cooking that are made of metal. Make another list of things used for cooking that are never made of metal. Discuss why the properties of metals determine which things are in which group.

Section 1 Review

 8.7.c 

SECTION VOCABULARY

element a substance that cannot be separated or broken down into simpler substances by chemical means

metal an element that is shiny and conducts heat and electricity well

metalloid an element that has properties of both metals and nonmetals

nonmetal an element that conducts heat and electricity poorly

pure substance a sample of matter, either a single element or a single compound, that has definite chemical and physical properties

1. Compare How does the ability to conduct heat differ between metals and nonmetals?

2. Classify Fill in the blanks to complete the table.

Element	Property	Classification
Copper	shiny solid	
Oxygen	gas	
Silicon	Electrical conductivity varies, depending on conditions.	

3. Evaluate Assumptions Your friend tells you that all of the electric wires in your home are metals. From what you know about elements, tell whether or not this statement is true. Explain your answer.

4. Apply Concepts Several elements are used between the panes of glass in double windows designed to block heat flow. From what category are these elements chosen. How do you know?

5. Make Calculations Two elements, hydrogen and helium, make up most of the atoms in the universe: 92.7% of atoms are hydrogen, and 6.9% of atoms are helium. What percentage of atoms in the universe is neither hydrogen nor helium? Show your work.

BEFORE YOU READ

After you read this section, you should be able to answer these questions:

- What are compounds made of?
- What happens during a chemical reaction?
- Are the properties of compounds like the properties of the elements used to make them?

**What Are Compounds?**

Most elements take part in chemical changes fairly easily, so they are rarely found in pure form in nature. Instead, they are found combined with other elements in compounds. A **compound** is a pure substance composed of two or more elements that are chemically combined. The figure below shows some compounds that you might find in your kitchen and what elements make up those compounds. ✓

Familiar Compounds

Compound	Elements combined
Table salt	sodium and chlorine
Water	hydrogen and oxygen
Sugar	hydrogen, carbon, and oxygen
Carbon dioxide	carbon and oxygen
Baking soda	sodium, hydrogen, carbon, and oxygen

A chemical change, or reaction, happens when one or more substances are changed into one or more other substances. During a chemical reaction, new substances form because atoms are rearranged. The properties of a compound can be very different from those of its elements. For example, water is made of hydrogen and oxygen. Both are gases at room temperature. Water is a liquid at room temperature. ✓

In some chemical reactions, two or more elements combine to form a compound. In other chemical reactions, a compound can be separated into elements or simpler compounds. Still other reactions involve changing compounds into other compounds. In all cases, though, different materials exist after the reaction occurs.

**STUDY TIP**

Ask Questions Read this section silently. In your notebook, write down questions that you have about the section. Discuss them in a small group.

**READING CHECK**

1. Describe What is a compound?

**READING CHECK**

2. Compare How do the properties of a compound compare with those of its elements?

SECTION 2 Compounds *continued*

What Properties Do Compounds Have?

Just as each element has physical and chemical properties, each compound has characteristic properties. Physical properties of compounds include melting point, boiling point, density, and color. The table below shows some of the physical properties of three colorless liquids. These properties can be used to tell them apart, even though the three compounds look alike in a container.

Physical Properties

	Melting point (°C)	Boiling point (°C)	Odor	Density (g/mL)
Chloroform	-64	61	strong	1.48
Ethanol	-114	75	mild	0.79
Water	0	100	none	1.00

Chemical properties can be used to identify compounds, too. Chemical properties include changes that occur when compounds are exposed to other chemicals or to heat or light. The figure below shows how the chemical properties of three common white solids differ.

Chemical Properties

	Reacts with acid	Flammable
Sodium chloride (salt)	no	no
Sucrose (sugar)	no	yes
Sodium bicarbonate (baking soda)	yes	no

The properties of a compound differ, not only from those of other compounds, but also from those of its elements. Sodium chloride is made of two very reactive and toxic elements—sodium and chlorine. Sodium is a metal that reacts violently with water and can cause damage if it touches skin. Chlorine is a poisonous gas. The combination of the two elements results in sodium chloride. Sodium chloride, or table salt, is safe to eat.

Critical Thinking

3. Analyze Data How can you tell from the table that all of the compounds listed are liquids at room temperature?

TAKE A LOOK

4. Identify What element is part of both of the non-flammable compounds in the table?



CALIFORNIA STANDARDS CHECK

8.5.a Students know reactant atoms and molecules interact to form products with different chemical properties.

Word Help: **interact** to act upon one another

5. Identify Give one property of sodium chloride that is not a property of sodium or chlorine.

SECTION 2 Compounds *continued***How Can I Tell Two Compounds Apart?**

You can tell one compound from another because every compound has a unique set of properties. This means that a compound can be identified by measuring or observing some of its properties. These properties are different for different compounds. ✓

Suppose you are given two white powders and told that one is powdered sugar and the other is baking soda. You must identify which is sugar without tasting it. How can you do this? Knowing that baking soda will fizz in an acid like vinegar, but sugar will not, gives you a way to identify the sugar.

You can put each powder into a beaker. Then, add some vinegar to each beaker. The powder that fizzes is the baking soda. ✓

Do Elements Always Combine in the Same Way to Make Compounds?

You may have heard that carbon monoxide is a poisonous gas and that plants use carbon dioxide to make oxygen. How are these compounds different? Carbon monoxide has one carbon atom combined with one oxygen atom. Carbon dioxide has one carbon atom combined with two oxygen atoms.

The properties of a compound depend on which elements combine and how much of each element is in the compound. It is similar to making words from letters. The same letters can be combined to make the words “hose” and “shoe,” but the words are different.

Can Compounds Be Broken Down?

Some compounds can be broken down into their elements by applying heat or using electricity. In the figure below, mercury oxide forms mercury and oxygen.



When mercury oxide is heated, it undergoes a chemical change in which it separates into the elements mercury and oxygen.

 **READING CHECK**

6. Identify How can a compound be identified?

 **READING CHECK**

7. Describe What chemical property of baking soda can be used to identify it from sugar?

 **Say It**

Discuss The paragraph to the left compares elements to letters of the alphabet. In small groups, discuss other comparisons that can help you better understand how compounds differ from one another.

TAKE A LOOK

8. Identify What is used to break down the mercury oxide into mercury and oxygen?

Section 2 Review

8.3.b, 8.5.a, 8.7.c 

SECTION VOCABULARY

compound a substance made up of atoms of two or more different elements joined by chemical bonds.

1. Explain How do the basic particles of a compound differ from the basic particles of an element?

2. Organize Fill in the Knowledge Web below with words from this section.

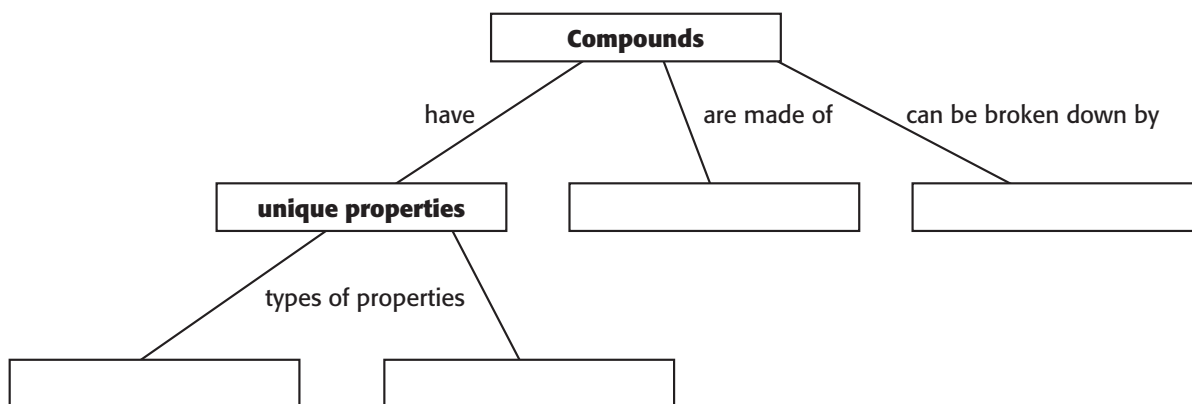

3. Draw Conclusions A plant label made of copper is bright and shiny when it is placed in the garden. After a few months, the label has a dull, greenish color. When you rub your finger over the surface, some soft material rubs off. What has happened to the copper?

4. Analyze Ideas If a piece of pure iron is placed in pure nitrogen, nothing happens. If the iron is exposed to air, it begins to rust. What conclusion can you make about air, based on this observation?

CHAPTER 5 Elements, Compounds, and Mixtures

SECTION

3

Mixtures

BEFORE YOU READ

After you read this section, you should be able to answer these questions:

- How do mixtures differ from elements and compounds?
- How can mixtures be separated?
- What are solutions, and how are they characterized?



California Science
Standards

8.7.c

What Are the Properties of Mixtures?

The illustration in the figure below shows a familiar mixture—a pizza. When you look at a piece of pizza, you can easily see different parts that have different properties. A **mixture** is a combination of two or more substances that are not chemically combined.

You can see each topping on this mixture, which is better known as a pizza.

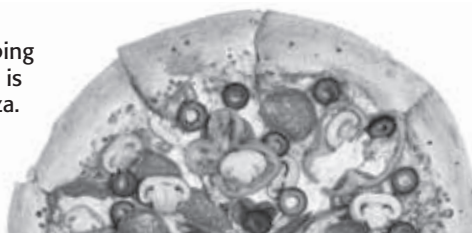

Chemicals can form mixtures. No chemical change happens when a mixture is made. That means that each chemical keeps its same identity. The pepperoni and olives on the pizza don't change when they are mixed. Making a mixture is therefore a physical change. ✓

Sometimes, you can see the components of the mixture. For example, if you mix sugar and sand together, you can see the different crystals in the mixture. In other mixtures, such as salt water, you cannot see the individual parts. Even so, there is no chemical reaction. You don't change the salt or the water by making the mixture.

Because the components of a mixture are not changed into new chemicals, they can often be separated easily. The olives and pepperoni can be picked off the pizza by hand. A magnet can pull iron particles out of a mixture of iron and sand. ✓

Other mixtures are not separated so easily. Salt can't simply be picked out of seawater. Salt can be separated from the water in salt water, though, by letting the water evaporate. Heating the seawater speeds up the process.

STUDY TIP

Brainstorm The main focus of this section is mixtures of substances. Brainstorm words and phrases related to mixtures. Record your work in your notebook.

READING CHECK

1. Identify What kind of change occurs when a mixture forms?

READING CHECK

2. Explain Why can mixtures often be separated easily?

SECTION 3 Mixtures *continued*

TAKE A LOOK

3. Identify Distillation always requires the addition of energy to convert a substance to a gas. How is energy added in the illustration?

How Can Mixtures Be Separated?

The figure below shows three methods of separating the parts of a mixture.

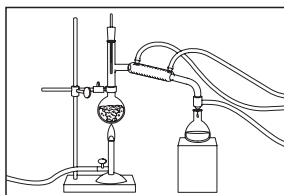

Distillation is the process that separates a mixture based on boiling points. Water in this mixture evaporates and then condenses as pure water.

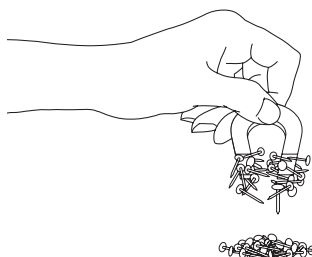

A **magnet** can be used to separate a mixture of the elements iron and aluminum. Iron is attracted to the magnet, but the aluminum is not.

Critical Thinking

4. Infer How does the separation of blood into several layers in a centrifuge show that blood is a mixture instead of a pure substance?

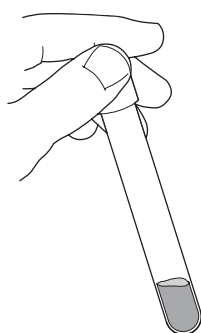

Blood is separated into its parts by a machine called a **centrifuge**. In the test tube of blood at the left, a layer of plasma rests on top of a layer of red blood cells. A centrifuge separates mixtures by the densities of the components.

Another method of separating the parts of a mixture is to dissolve one of the substances in water, filter the mixture, and then evaporate the water. This is shown below as a diagram called a *flow chart*. The flow chart for the separation of table salt and sulfur is illustrated.

TAKE A LOOK

5. Identify What is not collected in the process shown by the flow chart?



SECTION 3 Mixtures *continued***Do Mixtures Have Fixed Ratios?**

A compound is made of elements that are always present in a fixed ratio. For example, water is always two parts hydrogen and one part oxygen.

A mixture, however, does not have a fixed ratio of components. If you make a mixture of salt and water, you can put in a little salt or a lot of salt. Either way, you make a mixture. The figure below compares mixtures and compounds. ✓

Mixtures	Compounds
are made of elements, compounds, or both	are made of elements
keep the original properties of the components	do not have the original properties of the components
do not require heat or electricity for separation of components	require heat or electricity for separation of components
may have any ratio of components	must have a set ratio of components

What Is a Solution?

Salt water is an example of a solution. A **solution** is a *homogeneous* mixture. This means that a solution appears to be a single substance. The particles of the substances in a solution are evenly spread out. The appearance and properties are the same throughout the solution.

The process in which particles of substances separate and spread evenly throughout a mixture is known as *dissolving*. In a solution, the component that is present in the largest amount is called the **solvent**. Substances present in smaller amounts are called **solutes**. ✓

WATER AS A SOLVENT

Water is a very common solvent. In a salt water solution, water is the solvent, and salt is the solute. Water is the solvent of many of the solutions that you come across in daily life. In fact, your body contains many water solutions—blood plasma, saliva, and tears are all water solutions. Reactions inside cells take place in water solutions. So many different substances dissolve in water that it is often called the “universal solvent.” ✓

 **READING CHECK**

6. Compare How does the ratio of components in a mixture compare with the ratio of elements in a compound?

 **Say It**

Discuss Read “What Is a Solution?” Then, in small groups, discuss the solvent and solutes in soft drinks.

 **READING CHECK**

7. Identify In a solution, what component is present in the largest amount?

 **READING CHECK**

8. Identify What is called the universal solvent?

SECTION 3 Mixtures *continued*

Critical Thinking

9. Apply Ideas If you look at the side of a quarter, you can see layers of different metals. Is the coin a solid solution? Explain.

TAKE A LOOK

10. Identify In each of the example solutions, circle the name of the solute.

READING CHECK

11. Define What two things do you need to know in order to calculate concentration?

TYPES OF SOLUTIONS

Water is not the only solvent, though. Many other liquids dissolve substances, some of which do not dissolve in water. *Hydrocarbon solvents*, such as turpentine, are used to dissolve grease and other substances that don't dissolve in water.

In fact, solvents do not have to be liquids. Gases or even solids are able to act as solvents by dissolving other substances. The air around you is a solution of oxygen and other gases in nitrogen. Many familiar metals are *alloys*. Alloys, such as bronze, are solid solutions in which a metal is the solvent. Other metal or nonmetal elements are the solutes.

The table below shows some examples of solutions. The key point in forming a solution is that the particles of the components are evenly spread throughout the solution.

Examples of Solutions in Various States of Matter

State of matter	Example
Gas in a gas	dry air (oxygen in nitrogen)
Gas in a liquid	soft drinks (carbon dioxide in water)
Liquid in a liquid	antifreeze (an alcohol in water)
Solid in a liquid	salt water (salt in water)
Solid in a solid	brass (zinc in copper)

How Much Solute Can Be Added to a Solvent?

A measure of the amount of solute in a given amount of solvent is **concentration**. The concentration of a solution tells the mass of solute in a volume of solution. The units of concentration are grams of solute per milliliter of solvent (g/mL). As more solute is added, the concentration of the solution becomes greater.

Solutions are often described as being concentrated or dilute. A *dilute solution* is one that has a small amount of solute dissolved in the solvent. A *concentrated solution* has more solute in solution. These terms do not tell you the actual concentration of the solution. Rather, they describe a relative concentration.

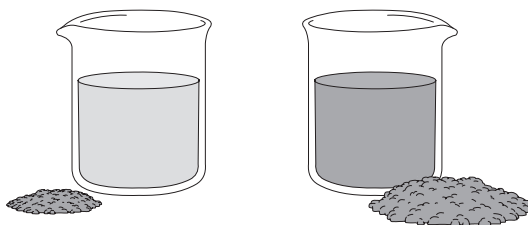

The dilute solution (left) contains less solute than the concentrated solution (right).

SECTION 3 Mixtures *continued*

SOLUBILITY

Is there a limit to the amount of solute that can be added to a solution? The answer is yes. Think about how you add sugar to lemonade. As you add some sugar to the lemonade and stir it, the sugar dissolves. If you add more sugar, you make a solution that is more concentrated. Eventually, no matter how much you stir, some sugar remains as a solid at the bottom of the glass.

To find the maximum amount of sugar that you could add to the lemonade, you need to know the solubility of sugar in water. **Solubility** refers to the ability of a solute to dissolve in a solvent at a certain temperature.

For most solids, the solubility in water increases as temperature increases. This is shown on the graph below as a line that slopes upward to the right. However, there are some exceptions. Does the graph show an exception to this rule? Yes, the line for cerium sulfate slopes downward to the right. This means that as the temperature increases, cerium sulfate gets less soluble.

Experiments have determined the solubility of many substances in various solvents. The graph below shows the solubility of several compounds in water.

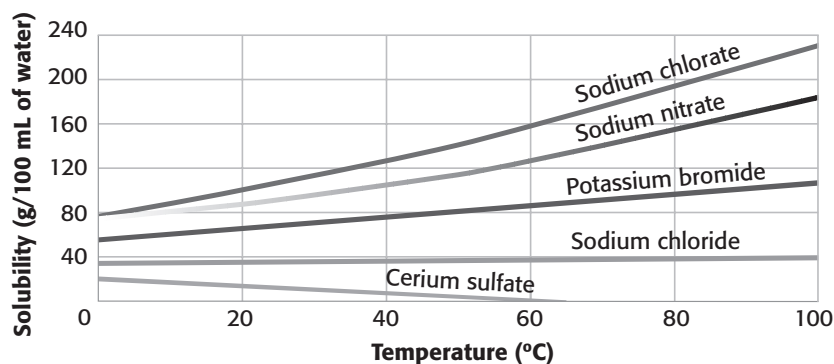

For most solids, solubility increases as temperature increases. Therefore, the amount of solute that can dissolve increases as the temperature increases. However, some solids, such as cerium sulfate, become less soluble as temperature increases.

Critical Thinking

12. Infer If you keep adding sugar to lemonade, why does the sugar eventually stop dissolving?

Math Focus

13. Read a Graph What is the solubility of sodium chlorate at 60°C?

Section 3 Review

 8.7.c 

SECTION VOCABULARY

concentration the amount of a particular substance in a given quantity of a mixture, solution, or ore

mixture a combination of two or more substances that are not chemically combined

solubility the ability of one substance to dissolve in another at a given temperature and pressure

Wordwise The root *solute-* means "to free" or "to loosen."

solute in a solution, the substance that dissolves the solute

solution a homogeneous mixture throughout which two or more substances are dispersed

solvent in a solution, the substance in which the solute dissolves

1. Identify What are the solvent and solute in a solution containing 100 g of ethanol and 3 g of sucrose?

2. Organize Complete the Concept Map for a mixture shown below.

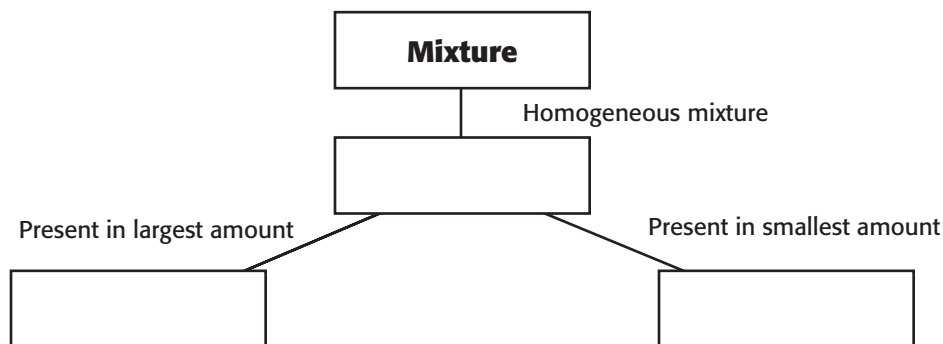

3. Analyze Processes In a steel factory, iron is melted. Then, other elements, such as carbon and nickel, are added to the melted iron to make steel. What is the reason for melting the iron?

4. Apply Concepts Suppose you added a cup of sugar to hot water, and all of the sugar dissolved. Then the water cooled, and some of the sugar was seen as a solid on the bottom of the beaker. Explain why this happened.

Development of the Atomic Theory

BEFORE YOU READ

After you read this section, you should be able to answer these questions:

- What is the atomic theory?
- How has the atomic theory changed?
- How do scientists observe atoms?



California Science Standards

8.3.a

What Is an Atom?

Imagine cutting something in half, then cutting again and again. Could you keep cutting forever? Around 440 BCE, a Greek philosopher named Democritus thought you would not be able to cut forever because you would eventually reach a smallest piece of matter. He called this particle an atom.

It was a long time before there was scientific evidence that Democritus was on the right track. We now know that all matter is made of tiny particles called atoms. An **atom** is the smallest particle into which an element can be divided and still keep its properties. ✓



Connect Concepts In your notebook, create a Concept Map about the scientists who studied atoms and what they learned.



1. Identify What is an atom?

What Was the First Scientific Theory of Atoms?

The first scientific theory about atoms was published by John Dalton in 1803. Unlike Democritus, Dalton based his ideas on experiments. His theory helped explain observations that he and other scientists had made about elements and compounds. Dalton's theory stated the following ideas:

- Atoms are small particles that cannot be created, destroyed, or divided.
- All substances are made of atoms.
- All atoms of one element are exactly alike.
- Atoms of different elements are different.
- Atoms can join with other atoms to make different substances.

Dalton Model of Hydrogen Atoms and Oxygen Atoms

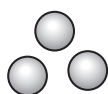

Hydrogen Atoms

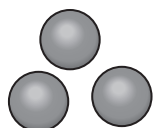

Oxygen Atoms

According to Dalton's theory, atoms cannot be divided or destroyed. Dalton's atoms can be modeled with hard metal balls.

TAKE A LOOK

2. Explain In the drawing, why do the oxygen atoms look different from the hydrogen atoms?

SECTION 1 Development of the Atomic Theory *continued*

Is Dalton's Theory Still Used?

Dalton's theory explained many observations about matter. However, by the end of the 1800s, scientists had made observations that did not fit exactly with Dalton's theory. Scientists changed the atomic theory to include this new knowledge. While the modern atomic theory is based on Dalton's theory, it is also very different. ✓

READING CHECK

3. Discuss When would scientists need to change a theory?

How Were Electrons Discovered?

In 1897, J. J. Thomson, a British scientist, discovered that atoms are not the smallest particles. There are even smaller particles inside the atom.

Thomson made this discovery when he was experimenting with mysterious invisible beams called cathode rays. Cathode rays were produced by connecting a special glass tube to a source of electricity. At the time, no one knew exactly what a cathode ray was made of.

To find out more about cathode rays, Thomson placed two metal plates inside the tube. He gave one plate a positive electrical charge and the other plate a negative charge. Thomson discovered that when he shot the cathode ray past the plates, it was attracted to the plate with the positive charge.

Thomson's Cathode-Ray Tube Experiment

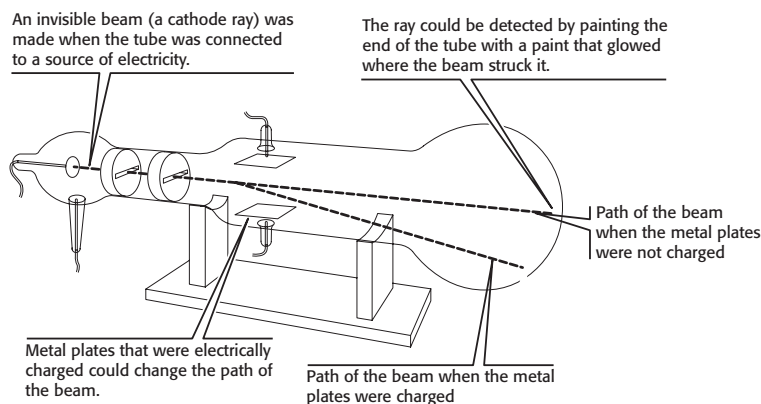

TAKE A LOOK

4. Identify What is the electrical charge on the plate that causes the beam to bend toward that plate?

READING CHECK

5. Identify What type of electrical charge does an electron have?

Thomson concluded that cathode rays must be made of tiny particles that come from atoms. Because the particles are attracted to a positively charged metal plate, the particles must have a negative charge. (Opposite charges attract each other.) The negatively charged particles found inside the atom are now called **electrons**. ✓

SECTION 1 Development of the Atomic Theory *continued***What Were Thomson's Conclusions?**

When Thomson discovered electrons, he was able to make several new conclusions about atoms. These conclusions included:

- There are particles (electrons) inside atoms.
- The particles have a negative charge.
- Because atoms have no electrical charge (they are neutral), they must also contain particles with positive charges that balance the negative charges. ✓

Notice that Thomson's conclusions do not fit exactly with Dalton's atomic theory. The atomic theory was changed to include a new description of atoms. However, other parts of Dalton's theory did not change. For example, scientists still knew that atoms of different elements are different. Scientists do not always need to discard a theory completely when new evidence is discovered.

What Is the "Plum-Pudding" Model?

Thomson's experiment showed that atoms contain electrons. However, it did not show where electrons are located inside the atom. Thomson suggested that electrons might be scattered throughout the atom.

This new model of the atom was called the *plum-pudding model*, named after a dessert that was popular at the time. Today, we would probably call this a "chocolate chip ice-cream" model of the atom. Electrons are scattered throughout the atom as chocolate chips are scattered through ice cream.

Chocolate Chip Ice Cream Model of an Atom

Thomson proposed a model that has electrons mixed throughout the atom. The rest of the atom has a positive charge.

READING CHECK

6. Explain How did Thomson know that atoms must contain particles with positive charges?

TAKE A LOOK

7. Compare What do the chocolate chips represent in a "chocolate chip ice cream model"?

SECTION 1 Development of the Atomic Theory *continued*

How Did Rutherford Study the Atom?

In 1909, one of Thomson’s former students designed a way to test his theory that electrons are scattered throughout the atom. Ernest Rutherford decided to shoot a beam of tiny, positively charged particles at a thin sheet of gold foil.

Rutherford assumed that atoms are soft blobs of matter with electrons and positively charged particles scattered through them. He thought that most of the particles he shot would pass right through the atoms of gold. Particles that hit other particles would stop or bounce off to the side.

When Rutherford performed the experiment, he found that most of the positively charged particles did pass through the gold foil. Some were deflected sideways, just as he expected. What surprised him was that some particles bounced straight back. ✓

READING CHECK

8. Identify What did Rutherford aim at the gold foil in his experiment?

TAKE A LOOK

9. Compare How did the number of particles that followed a straight path compare with the number that were deflected?

Rutherford’s Gold-Foil Experiment

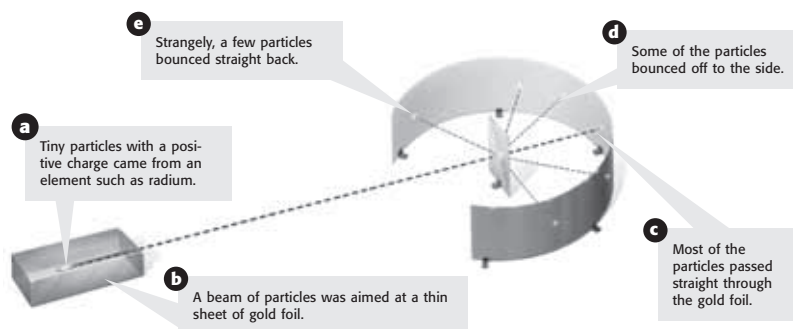

What Was Rutherford’s Atomic Model?

The plum-pudding model did not explain what Rutherford saw. He reasoned that there was only one way that the positively charged particles could bounce straight back. That was if they hit a very dense part of the atom that also had a positive charge. (Like charges repel.) He concluded that most of the matter in the atom must be in a very small part of the atom, not scattered throughout it. Based on the results of his experiment, Rutherford proposed a new model of the atom, the *nuclear model*.

In his model, the center of the atom is a tiny, dense, positively charged area called the **nucleus**. The electrons move outside the nucleus in mostly empty space.

CALIFORNIA STANDARDS CHECK

8.3.a Students know the structure of the atom and know it is composed of protons, neutrons, and electrons

10. Describe Where are the electrons found in an atom?

SECTION 1 Development of the Atomic Theory *continued*

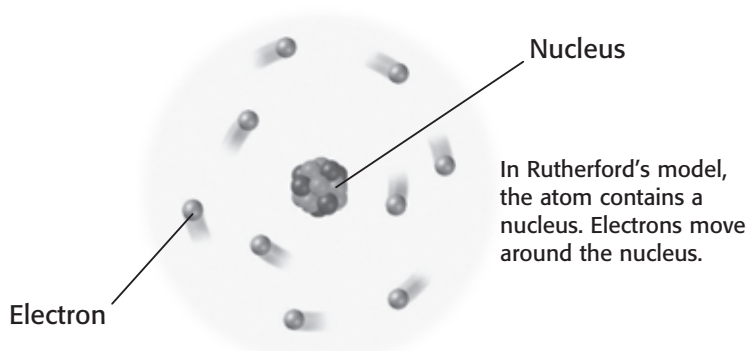

Math Focus

11. Make Comparisons If an atom had a nucleus 1 ft in diameter, what would be the diameter of the atom, in miles? Show your work. Round to the nearest mile. (1 mi = 5,280 ft)

How Big Is the Nucleus?

Rutherford concluded that the nucleus must be very small but very dense in order to deflect the fast-moving particles. He used his observations to calculate that the diameter of an atom is about 100,000 times greater than the diameter of its nucleus. The atom is mostly empty space. Electrons move in this space, around the nucleus.

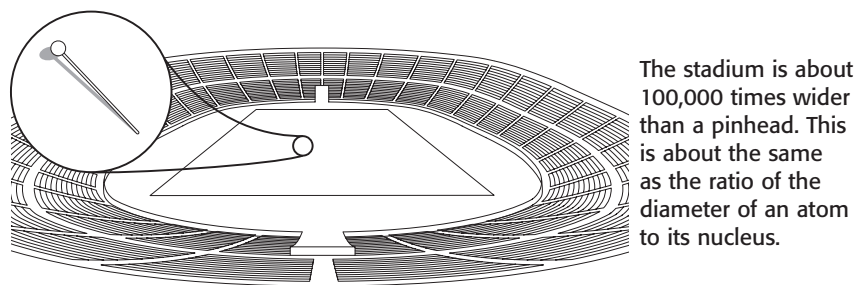

TAKE A LOOK

12. Identify In this comparison, what represents the nucleus of an atom?

Where Are the Electrons?

In 1913, Niels Bohr, a Danish scientist, studied the way that atoms react to light. He made a slight change to Rutherford's model, based on his observations. Bohr proposed that electrons move around the nucleus in definite paths, or orbits. In Bohr's model, electrons could not exist between these orbits. However, the electrons could jump from one orbit to another as they gained or lost energy. Once again, the atomic theory was revised to account for new data. ✓

READING CHECK

13. List What three new ideas about electrons did Bohr propose?

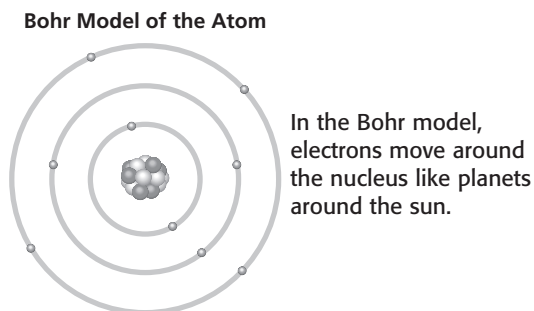

TAKE A LOOK

14. Identify Label the nucleus and the electrons in the figures.

SECTION 1 Development of the Atomic Theory *continued*

What Is the Modern Atomic Theory?

Atomic theory has changed over the past 100 years. Scientists such as Erwin Schrödinger from Austria, and Werner Heisenberg from Germany, have done important work. They have made observations that show that the Bohr model is not quite right.

Scientists still think that electrons are moving constantly around the nucleus. However, they now know that electrons do not orbit the nucleus, like planets orbit the sun. In fact, no one can ever know the exact path of an electron. No one can even predict the path an electron will follow as it moves around the nucleus. However, scientists can predict where electrons are likely to be found.

In the modern atomic model, the locations of electrons are described with **electron clouds**. Electron clouds are regions where electrons are most likely to be found. The figure below represents this model. ✓

READING CHECK

15. Define What are electron clouds?

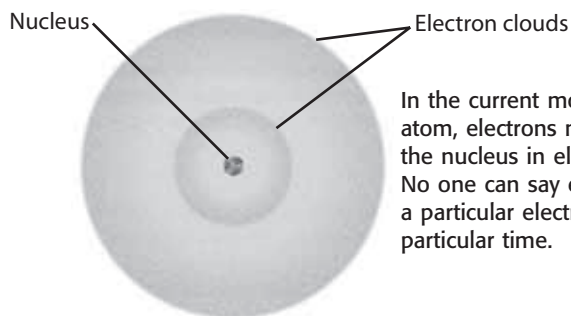

ENERGY LEVELS

Although electrons can't be found in any one particular place in an atom, there are certain *energy levels* that electrons can occupy. Electrons stay in motion because they have energy. As atoms gain and lose energy, electrons move from one energy level to another. The exact size and shape of a particular electron cloud depends on the energy of the electron.

TAKE A LOOK

16. Compare Fill in the table to compare the modern atomic model with the Bohr model.

Bohr model of the atom	Modern model of the atom
Electrons are tiny particles with a negative charge.	
Electrons are located outside the nucleus.	
Electrons orbit the nucleus in specific paths.	

SECTION 1 Development of the Atomic Theory *continued***Why Does a Theory Change?**

As scientists learn more about the structure of atoms, the atomic theory is revised again and again. This does not mean that previous explanations were “wrong.” Instead, it means that they provided a model of what was known about atoms at that time. These models were useful and helped scientists develop new experiments to learn more about atoms. Each of them led to a better understanding of the atoms.

The modern atomic theory has developed as scientists have learned more about the structure of these basic particles of elements. We know more about atoms today than Dalton did in 1803. The essential part of his theory is still the basic part of the modern atomic theory. The atoms of any particular element are different from the atoms of every other element. ✓

How Big Are Atoms?

Most of what we know about atoms was discovered without ever seeing an image of one. How small is an atom? The diameter of an atom is about one hundred-millionth of one centimeter (0.00000001 cm). Imagine a thin piece of aluminum foil. The foil is more than 100,000 atoms thick.

In fact, atoms are too small to be seen through a microscope. However, scientists today have tools that make images of atoms. One such tool is a scanning tunneling microscope (STM). This instrument uses the energy of electrons to make images. These images, like the one below, are not actual photographs. They are drawings made by a computer using information gathered by the STM.

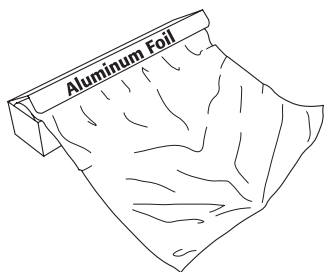

This piece of foil is more than 100,000 atoms thick.

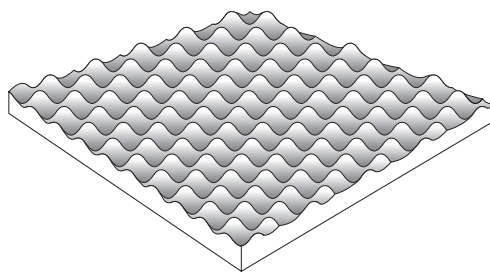

Scientists today can make images of atoms such as these, but most of what we know about atoms was learned by observing them indirectly.

 **READING CHECK**

17. Explain What was the essential part of Dalton’s atomic theory?

 **Say It**

Discuss There are about 100,000 atoms in the thickness of a piece of aluminum foil. In groups of two or three, discuss other things in your life that involve very large numbers. For example, how many people live in your city or town?

Math Focus

18. Calculate An aluminum can is about as thick as two pieces of aluminum foil. About how many atoms thick is an aluminum can?

Section 1 Review

SECTION VOCABULARY

<p>atom the smallest unit of an element that maintains the properties of that element</p> <p>Wordwise The prefix <i>a-</i> means “not.” The root <i>tom</i> means “to cut.”</p> <p>electron a subatomic particle that has a negative charge</p>	<p>electron cloud a region around the nucleus of an atom where electrons are likely to be found</p> <p>nucleus in physical science, an atom’s central region, which is made up of protons and neutrons</p>
--	--

1. Describe How does the size of the nucleus of an atom compare with that of its electron cloud?

2. Recall Finish the table below to summarize some of the advances in the development of atomic theory and those responsible for them.

Scientist	Idea that was added to the atomic theory
	Each element is made of a different type of atom.
Thomson	
Rutherford	
	Electrons are found in specific energy levels.
	You cannot predict exactly where an electron is or what path it will take.

3. Apply Concepts How did the discovery of electrons show that there are also positively charged parts of the atom?

4. Evaluate Theories What would cause scientists to change or replace the modern atomic theory?

5. Identify Label each of the models of the atoms as Dalton, Rutherford, Thomson, or Bohr.

Scientist	Description of atomic model
	electrons scattered throughout the atom
	electrons found in energy levels
	hard sphere that can’t be broken apart
	atom with a nucleus

SECTION 2 **The Atom**

BEFORE YOU READ

After you read this section, you should be able to answer these questions:

- What are the three parts of an atom?
- How are atoms of different elements different?
- How are different atoms of the same element different?
- What forces work inside atoms?



California Science Standards

8.3a, 8.7b

What Are the Parts of an Atom?

Atoms are made of three different types of particles: protons, neutrons, and electrons. As you have learned, electrons have a negative charge and are located in electron clouds outside the nucleus. You have also learned that the nucleus of an atom has a positive charge.

Protons are the particles inside the nucleus of an atom that give the nucleus its positive charge.

There are other particles inside the nucleus as well.

Neutrons are particles in the nucleus of an atom that do not have an electric charge. ✓

Parts of an Atom

_____ are negatively charged particles found in electron clouds outside the nucleus.

_____ are positively charged particles in the nucleus of an atom.

_____ are particles in the nucleus of an atom that have no charge.

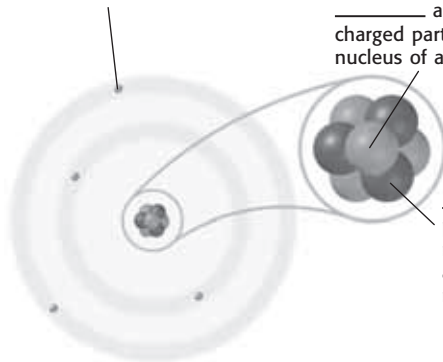

When the model of an atom is shown in a book, it does not show the correct scale of the particles in an atom. If protons were the size of those in an illustration, the electrons would need to be hundreds of feet away from the nucleus.

Because they are much smaller than an entire atom, protons, neutrons, and electrons are called *subatomic particles*. The properties of an element (such as its boiling point and the way it joins with other elements) depend on the number of subatomic particles in the atoms and the way that they interact.

STUDY TIP

Compare In your notebook, make a table to compare various characteristics of subatomic particles. Include mass, charge, and location in an atom.

READING CHECK

1. List What are the three types of subatomic particles in an atom?

TAKE A LOOK

2. Identify Fill in the names of the subatomic particles on the blank lines in the illustration.

SECTION 2 The Atom *continued*



CALIFORNIA STANDARDS CHECK

8.3.a Students know the structure of the atom and know it is composed of protons, neutrons, and electrons.

Word Help: structure the arrangement of the parts of a whole

3. Describe Where are the three types of subatomic particles located in an atom?



READING CHECK

4. Identify What is the SI unit for the mass of subatomic particles?

TAKE A LOOK

5. Identify Fill in the charge and mass of a neutron.

MASSES OF SUBATOMIC PARTICLES

Protons, neutrons, and electrons are all tiny particles. However, protons and neutrons are much more massive than electrons. Therefore, most of the mass of the atom is in the nucleus.

Each individual nucleus has very little mass because the mass of one proton is only about 1.7×10^{-24} g. This can also be written as 0.0000000000000000000000017 grams. Because this number is so small, scientists use a unit called the atomic mass unit, instead of grams, when they describe the masses of subatomic particles.

One **atomic mass unit**, or *amu*, is equal to the mass of one proton. Every proton has a mass of 1 amu. Neutrons have a little more mass than protons, but the difference is very small. Therefore, we say that the mass of a neutron is also 1 amu. ✓

Electrons are much smaller than protons and neutrons. You would need about 1,840 electrons to equal the mass of a proton. Electrons are so small that they are usually not included in calculating the mass of an atom.

ELECTRIC CHARGES OF SUBATOMIC PARTICLES

Although the masses of an electron and a proton are very different, their electric charges are the same size. However, the signs of the charges are opposite. Electrons have a negative charge, and protons have a positive charge. Neutrons, on the other hand, have no charge at all. Because each atom has an equal number of electrons and protons, atoms are neutral (they have no charge).

If an atom gains or loses an electron, it becomes an *ion*. An ion formed by losing an electron has a positive charge because it has more protons than electrons. An ion formed by gaining an electron has a negative charge because it has more electrons than protons.

Particle	Charge	Mass (amu)
Proton	1 ⁺	1
Neutron		
Electron	1 ⁻	1/1,840

SECTION 2 The Atom *continued*

How Are Atoms of Different Elements Different?

There are more than 110 elements known in the universe. Each element has atoms that are different from the atoms of all the other elements. All of the atoms of the same element have the same number of protons. Atoms of different elements have different numbers of protons.

For example, the simplest atom is hydrogen. Every hydrogen atom has one proton in its nucleus. An atom with two protons in its nucleus, however, is an atom of helium. Every helium atom has two protons.

The number of protons in the nucleus is called the **atomic number** of the atom. For example, because every oxygen atom has eight protons, the atomic number of oxygen is 8. The number of electrons is the same as the number of protons, so the atomic number also tells you how many electrons are in each atom. The periodic table lists the atomic number of each element. ✓

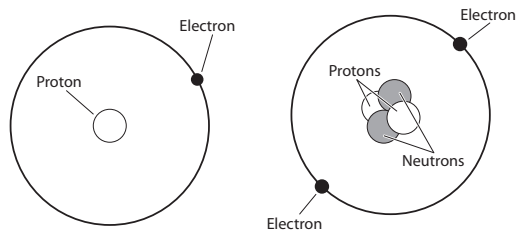

READING CHECK

6. Define What does atomic number tell you about an atom?

Comparison of a Hydrogen Atom and a Helium Atom		
Element	Hydrogen	Helium
Number of protons		
Number of neutrons		
Number of electrons		
Atomic number		

TAKE A LOOK

7. Organize In the table, fill in the blank boxes for each element.

SECTION 2 The Atom *continued*

What Do the Neutrons Do?

Notice that a helium atom does not have just protons and electrons. The helium nucleus also contains neutrons. In fact, the nucleus of every element except hydrogen contains neutrons. Neutrons play an important role in an atomic nucleus.

Remember that like charges repel one another. Inside an atomic nucleus, protons with the same charge are very close together. If there were no forces to hold them together, electrical repulsion would cause the protons to fly away from one another. Neutrons allow protons to exist very close together. ✓

READING CHECK

8. Describe What is the role of neutrons in the nucleus of an atom?

How Many Protons and Neutrons Can a Nucleus Have?

Because the protons repel each other, the atoms of every element, except hydrogen, must have neutrons in their nuclei. For example, most helium atoms have two protons and two neutrons.

The number of protons is not always the same as the number of neutrons. In fact, except in atoms with only a few protons, nuclei have more neutrons than protons. For example, most fluorine atoms have 9 electrons, 9 protons, and 10 neutrons. Most uranium nuclei have 92 protons and 146 neutrons.

TAKE A LOOK

9. Predict What would happen to the helium atom if the neutrons were removed?

A helium nucleus must have neutrons in it to keep the protons from moving apart.

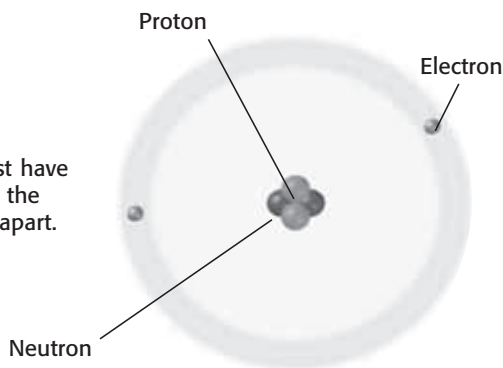

Notice that we said “most” uranium atoms have 146 neutrons. All uranium atoms have 92 protons. However, the number of neutrons can be different in different uranium atoms. There are also some uranium atoms that have 143 neutrons and some that have 142 neutrons. All atoms of the same element have the same number of protons, but they can have different numbers of neutrons.

SECTION 2 The Atom *continued*

What Are Isotopes?

Just as there are three different kinds of uranium atoms, there are also three different kinds of hydrogen atoms. Most hydrogen nuclei consist of a single proton. However, about 1 hydrogen nucleus out of every 10,000 also contains a neutron. It is also possible for a hydrogen nucleus to have two neutrons, but these atoms are very rare. Atoms that have the same number of protons but a different number of neutrons are called **isotopes**.

The two hydrogen atoms in the figure below are isotopes of each other. They are both hydrogen because each has only one proton. Because they have a different number of neutrons, they have different masses.

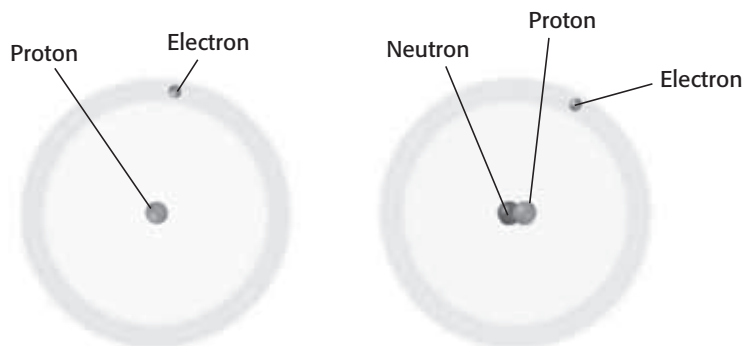

This isotope is a hydrogen atom that has one proton in its nucleus.

This isotope is a hydrogen atom that has one proton and one neutron in its nucleus.

SIMILARITIES BETWEEN ISOTOPES

For each element, there is a certain number of isotopes that exist in nature. Isotopes share most of the same physical and chemical properties.

For example, there are three isotopes of oxygen. The most common isotope of oxygen has 8 neutrons in its nucleus. Other oxygen isotopes have 9 or 10 neutrons. All three kinds of oxygen are colorless, odorless gases at room temperature. Each one can combine with a substance as the substance burns. When you breathe, you take oxygen into your body. The oxygen is needed for the chemical changes that keep you alive. All of the isotopes of oxygen take part in the chemistry of your body in the same way. ✓

CALIFORNIA STANDARDS CHECK

8.7.b Students know each element has a **specific** number of protons in the nucleus (the atomic number) and each isotope of the element has a different but specific number of neutrons in the nucleus.

Word Help: specific
unique; peculiar to or characteristic of; exact

10. Describe How are isotopes of an element different from one another?

READING CHECK

11. Explain Why doesn't it matter which isotope of oxygen you breathe?

SECTION 2 The Atom *continued*

DIFFERENCES BETWEEN ISOTOPES

The chemical and physical properties of isotopes are generally the same. However, some differences between isotopes are important. For example, some isotopes are unstable, which means that their nuclei change over time. Atoms with this type of nucleus are called radioactive. The nuclei of radioactive atoms give off small particles along with energy.

Another important difference between isotopes is mass. Because isotopes contain different numbers of neutrons, they have different masses. In fact, scientists name isotopes by their mass. The **mass number** of an isotope is the sum of the protons and neutrons in an atom. (Electrons are not included in the mass number because they are so small that they have very little effect on the total mass of the atom.)

The figure below shows two isotopes of boron. The isotope on the left has a mass number of 10. The isotope on the right has a mass number of 11 because it has one more neutron. To identify a specific isotope of an element, write the mass number after the element's name. The isotope on the left is called boron-10; the isotope on the right is called boron-11.

Two Isotopes of Boron



Protons: 5
 Neutrons: 5
 Electrons: 5
Mass number =
protons + neutrons = 10
 Boron-10

Protons: 5
 Neutrons: 6
 Electrons: 5
Mass number =
protons + neutrons = 11
 Boron-11

READING CHECK

12. Explain Can the mass number of an atom ever be smaller than its atomic number? Explain your answer.

READING CHECK

13. Identify Carbon has an atomic number of 6. How many protons and neutrons are in a nucleus of carbon-13?

Math Focus

14. Estimate We know that 99.985% of all hydrogen atoms are hydrogen-1. Only 0.015% are hydrogen-2 atoms. What is the approximate atomic mass of hydrogen?

What Is Atomic Mass?

The atomic mass of an element is the mass of one atom of the element. As you know, the mass of an atom equals the number of protons plus the number of neutrons. However, there are two or more isotopes of most elements. This means that the number of neutrons differs from atom to atom. The **atomic mass** of an element is the weighted average of the masses of all the natural isotopes of that element. For example, a sample of copper is about 69% copper-63 atoms and 31% copper-65 atoms. So, the atomic mass of copper is 63.6 amu.

SECTION 2 The Atom *continued*

What Forces Affect the Particles in Atoms?

Because charged particles attract and repel one another, there must be other forces that hold atoms and nuclei together. Scientists have discovered that there are four basic forces in nature. These forces work together to give atoms their structure and properties.

ELECTROMAGNETIC FORCE

The *electromagnetic force* causes objects with like charges to repel, and it causes objects with opposite charges to attract. Protons and electrons are attracted to one another because of the electromagnetic force. The electromagnetic force keeps the electrons and the nucleus together in an atom.

GRAVITATIONAL FORCE

Gravitational force pulls objects toward one another. It depends on the masses of the objects. Because subatomic particles are so small, the gravitational force has almost no effect within atoms.

STRONG FORCE

The *strong force* causes the protons and neutrons in the nucleus to be attracted to each other. It holds the nucleus together. Inside the nucleus, the attraction of the strong force is greater than the repulsion of the electromagnetic force. If there were no strong force, protons in the nucleus would repel one another, and the nucleus would fly apart.

WEAK FORCE

The *weak force* is important in radioactive atoms. In certain unstable atoms, a neutron can change into a proton and an electron. The weak force plays an important role in this change.



Discuss What would happen if each of the basic forces did not exist? Taking the forces one at a time, in a small group, discuss what would happen if that force didn't exist.

Critical Thinking

15. Make an Inference In some radioactive nuclei, a neutron can change into an electron and a proton. The electron leaves the nucleus, but the proton does not. What happens to the identity of the atom when this happens?

Forces in the Atom	
Description	Force
Force that affects changes of particles in the nucleus.	
Attractive interaction between objects with mass.	
Attractive force between particles in the nucleus	
Attractive or repulsive force between objects with opposite charges.	

TAKE A LOOK

16. Identify Fill in the names of the four forces in the table.

Section 2 Review

8.3.a, 8.7.b



SECTION VOCABULARY

atomic mass the mass of an atom expressed in atomic mass units

atomic mass unit a unit of mass that describes the mass of an atom or molecule

atomic number the number of protons in the nucleus of an atom; the atomic number is the same for all atoms of an element

isotope an atom that has the same number of protons (or the same atomic number) as other atoms of the same element do but that has a different number of neutrons (and thus a different atomic mass)

mass number the sum of the numbers of protons and neutrons in the nucleus of an atom

neutron a subatomic particle that has no charge and that is located in the nucleus of an atom

proton a subatomic particle that has a positive charge and that is located in the nucleus of an atom; the number of protons in the nucleus is the atomic number, which determines the identity of an element

subatomic

Wordwise The prefix *sub-* means “under.”

1. Compare Why do two isotopes of an element have the same atomic number but different mass numbers?

2. Organize Fill in the table below with the properties of the subatomic particles.

Particle	Charge	Mass (amu)
Proton		
Neutron		
Electron		

3. Apply Concepts Why does every element except hydrogen need at least one neutron in its nucleus?

4. Make Comparisons Compare the particles in the nuclei of carbon-14 and nitrogen-14.

Atom	Atomic number	Number of protons	Number of neutrons
Carbon-14	6		
Nitrogen-14	7		

CHAPTER 7 The Periodic Table

SECTION

1

Arranging the Elements

BEFORE YOU READ

After you read this section, you should be able to answer these questions:

- How are elements arranged on the periodic table?
- What are metals, nonmetals, and metalloids?
- What patterns are shown by the periodic table?



California Science Standards

8.3.f, 8.7.a, 8.7.b, 8.7.c

What Are Patterns of Elements?

By the 1860s, scientists had discovered more than 60 different elements. As they studied these elements, the scientists discovered that some elements had properties that were similar. For example, sodium and potassium are both metals that react violently with water. On the other hand, gold and silver are stable metals that react very slowly with water.

To understand the elements, chemists needed a way to organize what they knew about them. If they could find a pattern to these properties, it would help them understand how elements interact. A Russian chemist, Dmitri Mendeleev, discovered such a pattern in 1869. ✓

Mendeleev wrote the names of the elements and their properties on cards. When he arranged the cards in order of increasing atomic mass, he found that a pattern developed. He put elements that had similar properties in the same vertical column, as in the table below.

Hydrogen 1						
Lithium 7	Beryllium 9	Boron 11	Carbon 12		Oxygen 16	Fluorine 19
Sodium 23	Magnesium 24	Aluminum 27	Silicon 28		Sulfur 32	Chlorine 35
Potassium 39	Calcium 40					

The elements were placed in order by atomic mass. Sodium is similar to lithium and potassium, so they are in the same column. The same is true for elements in the other columns.



Clarify Concepts Take turns reading this section out loud with a partner. Stop to discuss ideas that seem confusing.



1. Describe What discovery allowed Mendeleev to organize the elements?

TAKE A LOOK

2. Predict Look at the pattern of atomic masses of the elements. Predict where elements X (atomic mass 31) and element Y (atomic mass 14) should be placed. Write them in the empty boxes in the table.

SECTION 1 Arranging the Elements *continued*



Discuss Many things occur in patterns that are periodic. In groups of three or four, discuss things in everyday life that occur at regular intervals. How many different types of patterns can you think of?

How Were the Patterns Used?

Mendeleev found that the pattern repeated several times. He started a new line with each element whose properties were similar to those of lithium. The result was that all the elements in the first column reacted in a similar way. All the elements in the second row also had similar properties. The pattern continued across the table—a periodic pattern. **Periodic** means “happening at regular intervals.”

Mendeleev found that the pattern of elements repeated after every seven elements. His table became known as the periodic table of the elements. The figure below shows part of a chart that Mendeleev made using his periodic table. Notice that there are several question marks beside atomic masses.

Mendeleev used question marks to note elements that he thought would be found later.

			Ni = 60
			Co = 59
H = 1			Cu = 63.4
	Be = 9.4	Mg = 24	Zn = 65.4
	B = 11	Al = 27.4	? = 68
	C = 12	Si = 28	⊙ = 70
	N = 14	P = 31	As = 75
	O = 16	S = 32	Se = 79.4
	F = 19	Cl = 35.5	Br = 80
Li = 7	Na = 23	K = 39	Rb = 85.4
		Ca = 40	Sr = 87.6
		? = 45	Ce = 92
		?Er = 56	La = 94
		?Yt = 60	Di = 95
		?In = 75.5	Th = 118?

TAKE A LOOK

3. Identify Look at Mendeleev’s chart. How many new elements did he predict would be discovered later?

When all the known elements were placed on the chart, there were places that did not line up. Mendeleev left several blank spots in his periodic table. He predicted that elements would be discovered that would fill those blanks.

By 1886, the gaps in the table had been filled by newly discovered elements. These elements had the properties that Mendeleev had predicted. The table below compares one of Mendeleev’s predictions with the actual element, germanium, discovered in 1871.

Math Focus

4. Compare Mendeleev predicted an atomic mass for the element that was later discovered and named germanium. How much does germanium’s actual atomic mass differ from his prediction?

Properties of Germanium		
	Mendeleev’s predictions (1869)	Actual properties
Atomic mass	70 amu	72.6 amu
Density*	5.5 g/cm ³	5.3 g/cm ³
Appearance	dark gray metal	gray metal
Melting point*	high	937°C

* at room temperature and pressure

SECTION 1 Arranging the Elements *continued*

What Does the Modern Periodic Table Look Like?

The first periodic table included only 63 elements. Today, scientists know about more than 100 elements, although some of them are very rare. The modern periodic table contains information that is similar to Mendeleev’s, but there are some differences.

The original periodic table displayed the elements in order of atomic mass. A few of the elements did not seem to be in the right order. Mendeleev placed them where he thought they should be, based on their properties. He thought that better atomic mass measurements would correct the problem.

In 1914, scientists began using *atomic numbers*. An atomic number is the number of protons in an atom. All of the elements fell into place when they were put in order by atomic number instead of atomic mass. The figure below shows a modern periodic table. ✓

Each horizontal row of elements, from left to right, is called a **period**. The physical and chemical properties of elements in a period follow the same pattern as those of the periods above and below. Each vertical column of elements (top to bottom) is called a **group**. Elements in a group tend to have similar chemical and physical properties. Groups are sometimes called families.

		Atoms of elements in Groups 1 and 2 have the same number of valence electrons as their group number.										Atoms of elements in Groups 13–18 have 10 fewer valence electrons than their group number. However, helium atoms have only 2 valence electrons.						18
H																		He
1	2	Atoms of elements in Groups 3–12 do not have a rule relating their valence electrons to their group number.										13	14	15	16	17	18	
Li	Be											B	C	N	O	F	Ne	
Na	Mg	3	4	5	6	7	8	9	10	11	12	Al	Si	P	S	Cl	Ar	
K	Ca	Sc	Ti	V	Cr	Mn	Fe	Co	Ni	Cu	Zn	Ga	Ge	As	Se	Br	Kr	
Rb	Sr	Y	Zr	Nb	Mo	Tc	Ru	Rh	Pd	Ag	Cd	In	Sn	Sb	Te	I	Xe	
Cs	Ba	La	Hf	Ta	W	Re	Os	Ir	Pt	Au	Hg	Tl	Pb	Bi	Po	At	Rn	
Fr	Ra	Ac	Rf	Db	Sg	Bh	Hs	Mt	Ds	Uuu	Uub	Uut	Uuq	Uup				

READING CHECK

5. Explain What property did Mendeleev use to sort the elements? What property has been used since 1914?

TAKE A LOOK

6. Describe How many groups and how many periods does the modern periodic table have? (Hydrogen and helium should be counted as the first period.)

SECTION 1 Arranging the Elements *continued*

How Are the Elements on the Table Classified?

When you look at the elements on the periodic table, three classes of elements are found. Usually, the classes of elements are related to the number of electrons in the outer energy level—the valence electrons. The number of valence electrons increases from left to right in a period. Based on their properties, the elements are classified as follows:

- metals—shown by darker shading to the left and center of the periodic table
- nonmetals—shown by lighter shading to the right side of the table
- metalloids—the region shown on either side of a zigzag line between the metals and nonmetals

The inert gases, Group 18 on the periodic table, are in the nonmetal group.

METALS

When you look at the periodic table, you can see that most of the elements are metals. Most metal atoms have few electrons in their outer energy levels. Except for mercury, which is a liquid, metals are solid at room temperature. The figure below shows some of the properties of metals.

 **CALIFORNIA STANDARDS CHECK**

8.7.a Students know how to identify regions corresponding to metals, nonmetals, and inert gases.

Word Help: identify
to point out or pick out

7. Compare How does the number of elements that are metals compare with the number of elements that are nonmetals?

Properties of Metals



Metals tend to be shiny, such as the reflective surface of this mirror.

Most metals are ductile, which means they can be drawn into thin wires like these copper wires. All metals are good conductors of electric current.



Most metals are malleable, which means they can be flattened without being shattered, as aluminum can be made into foil.



Most metals are good conductors of heat (thermal energy), like the iron in this griddle.



TAKE A LOOK

8. Identify Give five properties of metals that can be used to identify them as metals rather than nonmetals.

SECTION 1 Arranging the Elements *continued***NONMETALS**

Nonmetals are found on the right-hand side of the table. Atoms of most nonmetals have a nearly full outer energy level. Many of the nonmetal elements are gases at room temperature. In general, the properties of nonmetals are the opposite of the properties of metals. Some properties of nonmetals are described in the figure below. ✓

METALLOIDS

Metalloids are the elements found on either side of the zigzag line between metals and nonmetals. Their outer energy levels are about half filled. Metalloids have some of the properties of metals and some of the properties of nonmetals. Some of the properties of metalloids are described in the figure below.

Properties of Nonmetals and Metalloids

Nonmetals are not malleable or ductile. Solid nonmetals, such as carbon in the graphite of pencil lead, are brittle and will break or shatter when hit with a hammer.



Boron, a metalloid, is almost as hard as a diamond and is also very brittle. At high temperatures, it is a good conductor of electric current.

READING CHECK

9. Compare How are the outer energy levels of nonmetals different from the outer energy levels of metals?

TAKE A LOOK

10. Identify Circle the word in the figure's text that describes how a metalloid responds to a hammer blow.

What Information Is on the Periodic Table?

On the next page is a more detailed look at parts of the periodic table. It includes the two groups on the left-hand side of the table and the six groups on the right-hand side. Each block in the table gives information about one element. This information includes the element's name, its atomic number, and its atomic mass.

Each block also shows the chemical symbol of the element. The symbol is one or two letters that abbreviate the name of the element. These symbols are used in the chemical formulas for compounds. If you see an unfamiliar symbol in a formula, you can use the periodic table to identify the element. ✓

READING CHECK

11. Describe What is a chemical symbol?

SECTION 1 Arranging the Elements *continued*

TAKE A LOOK

12. List What are the four pieces of information about an element that are shown on the periodic table?

6	_____	Atomic number
C	_____	Chemical symbol
Carbon	_____	Element name
12.0	_____	Atomic mass

Each square on the periodic table of elements includes the element's name, chemical symbol, atomic number, and atomic mass.

Period 1	1 H Hydrogen 1.0							2 He Helium 4.0
	Group 1	Group 2	Group 13	Group 14	Group 15	Group 16	Group 17	Group 18
Period 2	3 Li Lithium 6.9	4 Be Beryllium 9.0	5 B Boron 10.8	6 C Carbon 12.0	7 N Nitrogen 14.0	8 O Oxygen 16.0	9 F Fluorine 19.0	10 Ne Neon 20.2
Period 3	11 Na Sodium 23.0	12 Mg Magnesium 24.3	13 Al Aluminum 27.0	14 Si Silicon 28.1	15 P Phosphorus 31.0	16 S Sulfur 32.1	17 Cl Chlorine 35.5	18 Ar Argon 39.9
Period 4	19 K Potassium 39.1	20 Ca Calcium 40.1	31 Ga Gallium 69.7	32 Ge Germanium 72.6	33 As Arsenic 74.9	34 Se Selenium 79.0	35 Br Bromine 79.9	36 Kr Krypton 83.8
Period 5	37 Rb Rubidium 85.5	38 Sr Strontium 87.6	49 In Indium 114.8	50 Sn Tin 118.7	51 Sb Antimony 121.8	52 Te Tellurium 127.6	53 I Iodine 126.9	54 Xe Xenon 131.3
Period 6	55 Cs Cesium 132.9	56 Ba Barium 137.3	81 Tl Thallium 204.4	82 Pb Lead 207.2	83 Bi Bismuth 209.0	84 Po Polonium (209)	85 At Astatine (210)	86 Rn Radon (222)
Period 7	87 Fr Francium (223)	88 Ra Radium (226)	113 Uut Ununtrium (284)	114 Uuq Ununquadium (289)	115 Uup Ununpentium (288)			

Critical Thinking

13. Analyze Relationships Scientists can make atoms of large elements never known before. Identify an element that would have properties like those of an atom with 118 protons.

A row of elements is called a *period*.

A column of elements is called a *group* or *family*.

SECTION 1 Arranging the Elements *continued***How Do You Read the Table?**

On the previous page, the top figure shows how to read a block on the periodic table. The symbol for the element is generally the largest item in a block. The atomic number is above the symbol. The name of the element and the atomic mass are below the symbol.

Notice that for elements with one-letter symbols, the symbol is always capitalized. For elements with two-letter symbols, the first letter is capitalized, and the second letter is lowercase. Three-letter symbols represent elements with temporary names. ✓

The bottom figure on the previous page shows part of the periodic table. It shows only eight groups of elements so it can fit onto the page. All of the elements follow the **periodic law**. The periodic law states that the repeating chemical and physical properties change periodically with the elements' atomic numbers. An atomic number is the number of protons in an atom of the element.

The atomic number increases from left to right in every period. However, the atomic mass does not always do so. There are several pairs of elements in which the atomic mass is greater for the element on the left. An example is tellurium and iodine in Period 5.

Most tellurium atoms have at least two more neutrons than iodine atoms have. That is why the atomic mass of tellurium is higher than the atomic mass of iodine, even though iodine has one more proton.

Finding the Atomic Number

Atomic Number: _____
Number of protons: _____

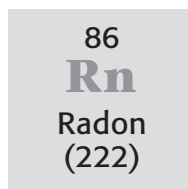

Atomic Number: _____
Number of protons: _____

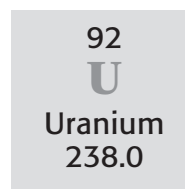

Atomic Number: _____
Number of protons: _____

READING CHECK

14. Identify What does a three-letter chemical symbol show?

TAKE A LOOK

15. Identify Fill in the blanks in the figure with the atomic number and the number of protons for each element. Use the information from the periodic table boxes.

Section 1 Review

8.3.f, 8.7.a, 8.7.b, 8.7.c 

SECTION VOCABULARY

<p>group a vertical column of elements in the periodic table; elements in a group share chemical properties</p> <p>period in chemistry, a horizontal row of elements in the periodic table</p>	<p>periodic describes something that occurs or repeats at regular intervals</p> <p>Wordwise The suffix <i>-ic</i> means “pertaining to.”</p> <p>periodic law the law that states that the repeating chemical and physical properties of elements change periodically with the atomic numbers of the elements</p>
--	---

1. Compare Which pair of elements is more likely to have similar properties: two elements in the same group or two elements in the same period?

2. Organize Fill in the table below with the correct classifications of the elements.

Location	Classification
Left-hand side and center of the periodic table	
Right-hand side of the periodic table	
Near the zigzag line toward the right-hand side of the periodic table	

3. Identify Relationships Use the periodic table to answer this question: Are the properties of rubidium (Rb) more similar to those of cesium (Cs) or those of strontium (Sr)? Explain your answer.

4. Apply Concepts Use the last periodic table in this section to identify the elements in the following compounds: PbS, KBr, and RaO.

5. Apply Concepts Use the periodic table to determine whether each of the following elements is a metal or a nonmetal: sodium (Na), krypton (Kr), and phosphorus (P).

CHAPTER 7 The Periodic Table

SECTION 2

Grouping the Elements

BEFORE YOU READ

After you read this section, you should be able to answer these questions:

- Why do elements in a group often have similar properties?
- What are the characteristic properties of the groups on the periodic table?
- How does hydrogen differ from other elements?



California Science Standards

8.7.a, 8.7.c

Why Are Elements in a Group Similar?

The elements in a group on the periodic table often—but not always—have similar properties. The properties are similar because the elements within a group have the same number of electrons in their outer energy level. Atoms often take, give, or share electrons with other atoms. Elements whose atoms have similar outer energy levels tend to react in similar ways. ✓



Organize Make a Venn Diagram for metals and nonmetals. As you read, indicate for each group whether it includes all metals, all nonmetals, or a both.

GROUP 1: ALKALI METALS

3
Li
Lithium

11
Na
Sodium

19
K
Potassium

37
Rb
Rubidium

55
Cs
Cesium

87
Fr
Francium

Group contains: metals
Electrons in the outer level: 1
Reactivity: very reactive
Other shared properties: softness, color of silver, shininess, low density

Alkali metals are elements in Group 1 of the periodic table. Alkali metals are the most reactive metals, which means they form compounds with other elements most easily. Their atoms tend to give away one of their outer-level electrons when they form compounds.

Alkali metals react with water and with oxygen in the air. In fact, they can cause a violent explosion when put into water. Alkali metals are so reactive that, in nature, they are found only in compounds with other elements. Compounds formed from alkali metals have many uses. One such compound, sodium chloride (table salt), is necessary in your diet.



1. Explain Why do the elements within a group of the periodic table have similar chemical properties?

TAKE A LOOK

2. List Write the names and atomic numbers of the alkali metal elements.

SECTION 2 Grouping the Elements *continued*

GROUP 2: ALKALINE-EARTH METALS

4
Be
Beryllium

12
Mg
Magnesium

20
Ca
Calcium

38
Sr
Strontium

56
Ba
Barium

88
Ra
Radium

Group contains: metals
Electrons in the outer level: 2
Reactivity: very reactive but less reactive than alkali metals
Other shared properties: color of silver, higher densities than alkali metals

Alkaline-earth metals are less reactive than alkali metals. Atoms of alkaline-earth metals have two outer-level electrons. It is more difficult for atoms to lose two electrons than to lose one. That means alkaline-earth metals tend to react more slowly than alkali metals, but they are still very reactive. ✓

Group 2 elements and their compounds have many uses. For example, magnesium can be mixed with other metals to make low-density parts for airplanes. Compounds of calcium are found in chalk, cement, and even in your bones and teeth.

READING CHECK

3. Explain Why are the alkaline-earth metals less reactive than the alkali metals?

TAKE A LOOK

4. Identify How many protons does the largest transition metal have in its nucleus?

GROUPS 3 TO 12: TRANSITION METALS

21 Sc	22 Ti	23 V	24 Cr	25 Mn	26 Fe	27 Co	28 Ni	29 C	30 Zn
39 Y	40 Zr	41 Nb	42 Mo	43 Tc	44 R	45 Rh	46 Pd	47 Ag	48 Cd
57 La	72 Hf	73 Ta	74 W	75 Re	76 Os	77 Ir	78 Pt	79 A	80 Hg
89 Ac	104 Rf	105 Db	106 Sg	107 Bh	108 Hs	109 Mt	110 Ds	111 u	112 u b

Group contains: metals
Electrons in the outer level: 1 or 2
Reactivity: less reactive than alkaline-earth metals
Other shared properties: shininess, good conduction of thermal energy and electric current, higher densities and melting points than elements in Groups 1 and 2 (except for mercury)

Elements of Groups 3 to 12 are called transition metals. The atoms of transition metals do not give away their electrons as easily as atoms of Group 1 or Group 2 metals.

SECTION 2 Grouping the Elements *continued***PROPERTIES OF TRANSITION METALS**

The number of outer-level electrons in atoms of transition metals varies. The properties of these metals also vary widely. For example, iron forms rust when exposed to air and water. Gold and platinum, however, are very unreactive. Jewelry and other gold objects that are thousands of years old still look new.

Because they are metals, transition metals all share the common properties of metals. They tend to be shiny, malleable, and ductile. They conduct thermal energy and electric current well. Many of the transition metals have very high melting points compared with other elements. One exception is mercury, which is a liquid at room temperature. Many of the transition metals are familiar as structural materials, coins, and jewelry. ✓

GROUP 13: BORON GROUP

5
B
Boron

13
Al
Aluminum

31
Ga
Gallium

49
In
Indium

81
Tl
Thallium

113
Uut
Ununtrium

Group contains: one metalloid and five metals

Electrons in the outer level: 3

Reactivity: reactive

Other shared properties: solid at room temperature

The most common element from Group 13 is aluminum. In fact, aluminum is the most common metal in Earth's crust. Until the 1880s, however, aluminum was considered a precious metal. Today, making pure aluminum is easier and cheaper than it was in the 1800s.

Aluminum is useful because it is such a lightweight, but strong, metal. It is used in aircraft parts parts, lightweight automobile parts, foil, cans, and garage doors. ✓

Like other elements in the boron group, aluminum is reactive. However, when aluminum reacts with oxygen in the air, a thin layer of aluminum oxide quickly forms on aluminum's surface. This layer prevents it from reacting further.

 **READING CHECK**

5. Identify Which transition metal has the lowest melting point?

TAKE A LOOK

6. List Write the atomic numbers of the elements in Group 13.

 **READING CHECK**

7. Explain Why is aluminum a good choice of metal for airplane bodies?

SECTION 2 Grouping the Elements *continued***GROUP 14: CARBON GROUP**6
C
Carbon14
Si
Silicon32
Ge
Germanium50
Sn
Tin82
Pb
Lead114
Uuq
Ununquadium**Group contains:** one nonmetal, two metalloids, and three metals**Electrons in the outer level:** 4**Reactivity:** varies among elements**Other shared properties:** solid at room temperature

Group 14 includes several well-known and useful elements. The nonmetal carbon can be found uncombined in nature, as diamond and as soot from burning wood, oil, or coal.

Carbon also forms a wide variety of compounds. Some of these compounds, such as proteins, fats, and carbohydrates, are necessary for all living things.

Silicon and germanium are metalloids. They are used in semiconductors. These are important components of computers and other electronic devices. Tin and lead are soft, relatively unreactive metals. A layer of tin keeps steel cans from rusting. Lead is used in automobile batteries.

GROUP 15: NITROGEN GROUP7
N
Nitrogen15
P
Phosphorus33
As
Arsenic51
Sb
Antimony83
Bi
Bismuth115
Uup
Ununpentium**Group contains:** two nonmetals, two metalloids, and two metals**Electrons in the outer level:** 5**Reactivity:** varies among elements**Other shared properties:** solid at room temperature (except for nitrogen)

Nitrogen, which is a gas at room temperature, makes up about 80% of the air that you breathe. In general, nitrogen is fairly unreactive. Nitrogen can be made to react with hydrogen to make ammonia for fertilizers.

Phosphorus is an extremely reactive nonmetal. In nature, it is always found combined with other elements. Because it is so reactive, phosphorus is used to make matches. The heat of friction against the box provides the energy to cause phosphorus to start burning.

TAKE A LOOK

8. Identify Which element in Group 14 is classified as a nonmetal?

TAKE A LOOK

9. Identify What are the chemical symbols for the elements nitrogen and phosphorus?

SECTION 2 Grouping the Elements *continued***GROUP 16: OXYGEN GROUP**8
O
Oxygen16
S
Sulfur34
Se
Selenium52
Te
Tellurium84
Po
Polonium**Group contains:** three nonmetals, one metalloid, and one metal**Electrons in the outer level:** 6**Reactivity:** reactive**Other shared properties:** solid at room temperature (except oxygen)

About 20% of the air is oxygen. Oxygen is necessary for anything to burn. It is also important to most living things. Dissolved oxygen in water is necessary for fish to live.

Sulfur is another common member of Group 16. Sulfur can be found in natural deposits as a brittle, yellow solid. It is used to make sulfuric acid, which is the most widely used compound in the chemical industry.

GROUP 17: HALOGENS9
F
Fluorine17
Cl
Chlorine35
Br
Bromine53
I
Iodine85
At
Astatine**Group contains:** nonmetals**Electrons in the outer level:** 7**Reactivity:** very reactive**Other shared properties:** poor conduction of electric current, violent reaction with alkali metals to form salts, never in uncombined form in nature

Halogens are very reactive nonmetal elements that need to gain only one electron to have a complete outer level. The atoms of the halogens combine readily with other atoms, especially metals, to gain the extra electron. The reaction of a halogen with a metal makes a salt, such as sodium chloride.

Both chlorine and iodine are used as disinfectants. Chlorine is used to treat water for drinking and swimming. Iodine mixed with alcohol makes a germ killer used in hospitals.

Although the chemical properties of halogens are similar, their physical properties can be quite different. For example, at room temperature, fluorine and chlorine are gases, bromine is a liquid, and iodine is a solid. Astatine is a very rare element.

 **READING CHECK**

10. Describe What are the physical properties of the element sulfur?

TAKE A LOOK

11. List What are the names and atomic numbers of the halogens?

SECTION 2 Grouping the Elements *continued*

CALIFORNIA STANDARDS CHECK

8.7.a Students know how to identify regions corresponding to metals, nonmetals, and inert gases.

Word Help: identify to point out or pick out

12. Explain What evidence do scientists have that the inert gases are not completely inert?

Critical Thinking

13. Evaluate Models

According to the current model of the atom, the atoms are most stable when they have filled outer energy levels. How do the properties of noble gases support this model?

GROUP 18: NOBLE GASES

2 He Helium
10 Ne Neon
18 Ar Argon
36 Kr Krypton
54 Xe Xenon
86 Rn Radon

Group contains: nonmetals
Electrons in the outer level: 8 (except helium, which has 2)
Reactivity: unreactive
Other shared properties: colorless odorless gas at room temperature

Noble gases are unreactive gases found in Group 18 of the periodic table. The atoms of the noble gases have completely filled outer levels. This means that they do not need to gain or lose electrons to become stable.

Under normal conditions, these elements do not react with other elements. In fact, they are sometimes called inert gases because scientists once believed that they do not react at all. However, scientists have made compounds with some of the Group 18 elements. This is why they are usually called noble gases instead of inert gases.

Because the noble gases are so unreactive, they are very difficult to detect chemically. None of them was known when Mendeleev put together his first periodic table. In fact, the first noble gas was not discovered on Earth, but in the sun. Helium was first detected by its effect on light from the sun. *Helios* is the Greek word for “sun.”

Argon is the most common noble gas on Earth, making up about 1% of the atmosphere. All of the noble gases are found in small amounts.

The unreactivity of the Group 18 elements makes them useful. For example, ordinary light bulbs last longer when they are filled with argon. Because argon is unreactive, it does not react with the hot metal filament of the bulb. A more reactive gas could react with the filament and cause the bulb to burn out sooner.

Noble gases are also used in colorful light tubes. They glow in bright colors when exposed to a strong electric charge. These lights are often called “neon lights.” This is because the first tubes used neon to produce a bright red glow.

SECTION 2 Grouping the Elements *continued***HYDROGEN****Electrons in the outer level:** 1**Reactivity:** reactive**Other properties:** colorless, odorless gas at room temperature; low density; explosive reaction with oxygen

Hydrogen is the most abundant element in the universe. It is found in large amounts in stars. Atoms of hydrogen can give away one electron when they join with other atoms. Hydrogen reacts with many elements and is found in many familiar compounds. Hydrogen is so reactive that it can be used as fuel for rockets.

The properties of hydrogen do not match those of any group of the periodic table. Therefore, hydrogen is set apart from the rest of the elements on the table. It is shown above Group 1 because the atoms of alkali metals also lose one electron when they combine with other atoms. However, the physical properties of hydrogen are more like those of nonmetals than of metals. Hydrogen is in a group all by itself. ✓

LANTHANIDES AND ACTINIDES

These metals are part of the transition metals. They are not shown on the periodic table in this chapter. However, many periodic tables show them as two rows at the bottom of the table. Each row has 15 metal elements, which tend to have very similar properties. The lanthanides are often mixed with other metals to make them stronger. The best known actinide is uranium, which is used in nuclear power plants.

SYNTHETIC (MAN-MADE) ELEMENTS

Many of the very large elements are not found naturally on Earth. Elements with atomic numbers greater than 92 (uranium) are made by forcing nuclear particles together. For example, uranium (#92) and carbon (#6) nuclei join to make californium (#98). After a new element is made, it is placed on the periodic table. It is given a temporary name and symbol until scientists agree on a permanent name for the new element.

READING CHECK

14. Explain Why is hydrogen not included in any group of the periodic table?

Critical Thinking

15. Apply Concepts Scientists can make new elements by forcing particles together. How do you know that all of the new elements will be larger than uranium?

Section 2 Review

8.7.a, 8.7.c 

SECTION VOCABULARY

alkali metal one of the elements of Group 1 of the periodic table (lithium, sodium, potassium, rubidium, cesium, and francium)

alkaline-earth metal one of the elements of Group 2 of the periodic table (beryllium, magnesium, calcium, strontium, barium, and radium)

halogen one of the elements of Group 17 of the periodic table (fluorine, chlorine, bromine, iodine, and astatine); halogens combine with most metals to form salts

noble gas one of the elements of Group 18 of the periodic table (helium, neon, argon, krypton, xenon, and radon); noble gases are unreactive

1. Explain Why are the alkali metals and the halogens among the most reactive elements on the periodic table?

2. Recall Complete the Concept Map below with words from this section.

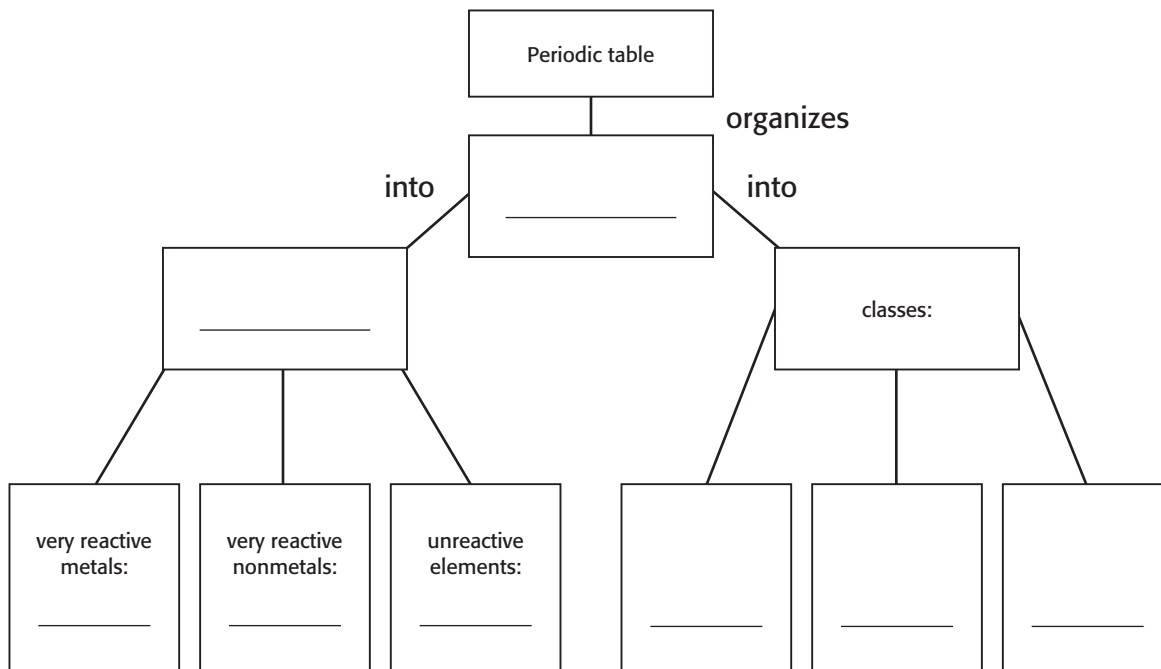

3. Apply Concepts Why were the noble gases among the last of the naturally occurring elements to be discovered?

4. Identify Relationships How are all of the nonmetal elements on the periodic table related, in terms of ability to lose electrons?

Electrons and Chemical Bonding

BEFORE YOU READ

After you read this section, you should be able to answer these questions:

- What is chemical bonding?
- What are valence electrons?
- How do valence electrons affect bonding?



California Science Standards

8.3.a, 8.3.b, 8.3.f

What Is a Chemical Bond?

All things are made of atoms. A few substances are made of single atoms, but most are made of two or more atoms joined together. **Chemical bonding** is the joining of atoms to form a new substance. The bond that forms when two atoms join is called a **chemical bond**. Chemical bonds form when electrons in atoms interact. Atoms can gain, lose, or share electrons to form a chemical bond. ✓

In some cases, the atoms that join together are atoms of the same element. Oxygen gas, for example, is made of two oxygen atoms bonded together. In other cases, atoms of different elements bond. For example, hydrogen and oxygen atoms bond to form water.



Clarify Concepts Take turns reading this section out loud with a partner. Stop to discuss ideas that seem confusing.



1. Explain What happens to electrons in an atom when a chemical bond forms?

ELECTRONS IN ATOMS

Remember that electrons are found outside the nucleus in layers called *energy levels*. Each energy level can hold a certain number of electrons. The first energy level is closest to the nucleus. It can hold up to two electrons. The second energy level can hold up to eight electrons. The third energy level can also hold up to eight electrons. ✓

Electron Arrangement in an Atom of Chlorine

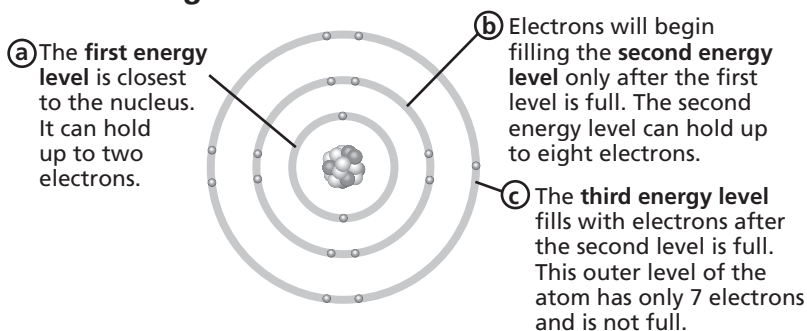

2. Describe Where are electrons found in an atom?

SECTION 1 Electrons and Chemical Bonding *continued***Which Electrons Affect Bonding?**

Atoms form chemical bonds when their electrons interact with one another. However, not all of the electrons in an atom interact with electrons in other atoms to form bonds. In most cases, only the electrons in the outermost energy level are able to form bonds. Electrons in the outermost energy level are called **valence electrons**. In order to learn what kinds of bonds an atom can form, you need to know how many valence electrons it has. ✓

READING CHECK

3. Explain Where are the valence electrons found in an atom?

Critical Thinking

4. Apply Concepts The atomic number of carbon is 6. How many protons does an atom of carbon have? How many electrons?

DETERMINING THE NUMBER OF VALENCE ELECTRONS

The *atomic number* of an element tells you how many protons are in an atom of the element. No two elements have the same number of protons in their atoms, so no two elements have the same atomic number. The number of protons in an atom equals the number of electrons in the atom. Therefore, the atomic number also tells how many electrons are found in an atom of an element.

You can use an element's atomic number to learn how many valence electrons its atoms have. In order to do this, you need to draw a model of the atom. Remember that valence electrons are in the outermost level. For example, the figures below show models of two atoms.

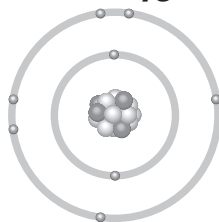
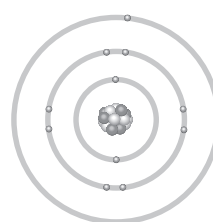
Model of an Oxygen Atom**Model of a Sodium Atom**

The figure on the left is a model of an atom of oxygen. Oxygen's atomic number is 8. Therefore, its atoms have 8 electrons in them. The first energy level holds 2 electrons. The second, outermost energy level has 6 electrons in it. Therefore, oxygen has 6 valence electrons.

The figure on the right shows a model of a sodium atom. Sodium's atomic number is 11. Its atoms have 11 electrons in them. The first energy level holds 2 electrons. The second energy level holds 8 electrons. The third, outermost energy level holds 1 electron. Therefore, sodium has 1 valence electron.

CALIFORNIA STANDARDS CHECK

8.3.a Students know the structure of the atom and know it is composed of protons, neutrons, and electrons.

5. Identify Label the nucleus in the oxygen atom.

SECTION 1 Electrons and Chemical Bonding *continued***USING THE PERIODIC TABLE TO FIND VALENCE ELECTRONS**

You can also use the periodic table to find the number of valence electrons in an atom. Each column in the table is a *group*. The atoms of all of the elements in a group have the same number of valence electrons. The only exception to this rule is helium. Helium has two valence electrons. All of the other atoms in its group have eight valence electrons.

Atoms of elements in **Groups 1 and 2** have the same number of valence electrons as their group number.

Atoms of elements in **Groups 13–18** have 10 fewer valence electrons than their group number. However, helium atoms have only 2 valence electrons.

H																	18
1	2											13	14	15	16	17	He
Li	Be											B	C	N	O	F	Ne
Na	Mg	3	4	5	6	7	8	9	10	11	12	Al	Si	P	S	Cl	Ar
K	Ca	Sc	Ti	V	Cr	Mn	Fe	Co	Ni	Cu	Zn	Ga	Ge	As	Se	Br	Kr
Rb	Sr	Y	Zr	Nb	Mo	Tc	Ru	Rh	Pd	Ag	Cd	In	Sb	Sb	Te	I	Xe
Cs	Ba	La	Hf	Ta	W	Re	Os	Ir	Pt	Au	Hg	Tl	Pb	Bi	Po	At	Rn
Fr	Ra	Ac	Rf	Db	Sg	Bh	Hs	Mt	Ds	Uuu	Uub	Uut	Uuq	Uup			

Atoms of elements in **Groups 3–12** do not have a rule relating their valence electrons to their group number.

Math Focus

6. Analyze Data Use the periodic table to figure out how many valence electrons the elements in Group 16 have.

Why Do Atoms Bond?

Some atoms form bonds easily. Others don't. How an atom bonds and how easily it bonds depend on the number of valence electrons. An atom forms a bond with another atom in order to complete, or fill, its outermost energy level. An atom is most stable when its outermost energy level is full. ✓

The atoms in Group 18 (at the far right) have full outermost energy levels. Therefore, they do not usually form bonds. However, atoms in the other groups have outermost energy levels that are not full. These atoms fill their outermost energy levels by forming bonds. For most atoms, eight electrons will fill the outermost energy level.

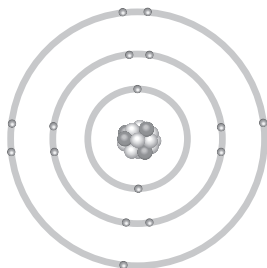
Filling Outermost Energy Levels

Sulfur An atom of sulfur has six valence electrons. It can have eight valence electrons by sharing two electrons with or gaining two electrons from other atoms.

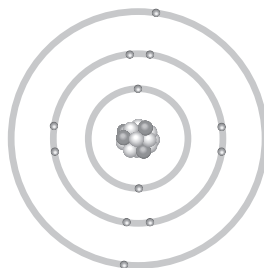

Magnesium An atom of magnesium has two valence electrons. It can have a full outer level by losing two electrons. The second energy level becomes the outermost energy level and has eight electrons.

READING CHECK

7. Explain Why do atoms bond with one another?

TAKE A LOOK

8. Apply Concepts Calcium (Ca) is in the same group as magnesium. Does it tend to gain or lose electrons when it bonds?

Section 1 Review

8.3.a, 8.3.b, 8.3.f



SECTION VOCABULARY

chemical bonding the combining of atoms to form molecules or ionic compounds

chemical bond an interaction that holds atoms or ions together

valence electron an electron that is found in the outermost shell of an atom and that determines the atom's chemical properties

1. Identify How do atoms form chemical bonds?

2. Use Models Fluorine is an atom with two electrons in its innermost energy level and seven in its outermost level. Draw the electrons around the nucleus. Color the valence electrons in a different color.

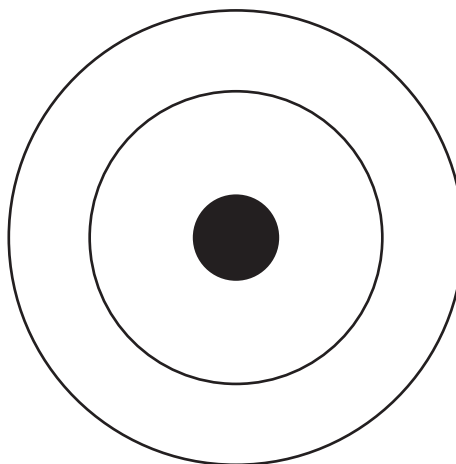

3. Apply Concepts How can an atom that has seven valence electrons complete its outermost level?

4. Apply Concepts Magnesium (Mg) has two electrons in its outermost energy level. Oxygen (O) has six. How can a Mg atom bond with an O atom?

5. Interpret Graphics Each box in the periodic table contains an element symbol and the element's atomic number. Using the box below, answer the questions about sulfur (S) next to the box.

16
S

How many protons does an atom of sulfur have? _____

How many electrons does an atom of sulfur have? _____

CHAPTER 8 Chemical Bonding

SECTION

2

Ionic Bonds

BEFORE YOU READ

After you read this section, you should be able to answer these questions:

- What is ionic bonding?
- What happens to atoms that gain or lose electrons?
- What kinds of solids are formed from ionic bonds?



California Science Standards

8.3.a, 8.3.b, 8.3.c, 8.5.a

How Do Ionic Bonds Form?

There are several types of chemical bonds. An ionic bond is one type. **Ionic bonds** form when valence electrons are transferred from one atom to another.

Like other bonds, ionic bonds form so that the outermost energy levels of the atoms that bond are filled. To understand why ionic bonds form, you need to learn what happens when atoms gain or lose electrons. ✓

What Happens When Atoms Gain or Lose Electrons?

An electron has a negative electrical charge. A proton has a positive electrical charge. An atom is *neutral*, or not charged, because the number of electrons in an atom equals the number of protons. The electrical charges cancel each other out.

Atoms that have gained or lost electrons are called **ions**. When an atom gains or loses electrons, the numbers of protons and electrons are no longer equal. Therefore, ions are not neutral like atoms. Atoms that lose electrons become positively charged ions because they have more protons than electrons. Atoms that gain electrons become negatively charged ions because they have more electrons than protons. ✓

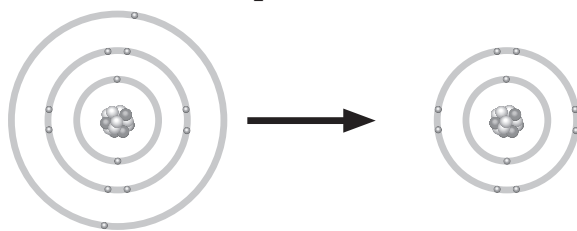

A magnesium atom can lose its two valence electrons to another atom. The filled second level then becomes the outermost energy level. The magnesium ion has eight valence electrons.

STUDY TIP

Ask Questions As you read, make a list of questions that you have. Talk about your questions in a small group.

**READING CHECK**

1. Explain How does an ionic bond form?

**READING CHECK**

2. Explain How are ions different from atoms?

SECTION 2 Ionic Bonds *continued***How Do Positive Ions Form?**

Electrons have a negative charge. Therefore, they are attracted to the positive charge of the protons in the nucleus. In order for an atom to lose an electron, the attraction between the electron and the protons has to be broken. Breaking the attraction takes energy. This energy is released when an ionic bond forms. ✓

READING CHECK

3. Explain What has to happen in order for an atom to lose an electron?

Compared with other elements, only a small amount of energy is needed for metals to lose their valence electrons. Therefore, metals are much more likely to form positive ions than other elements are. Examples of metals are silver, sodium, copper, and aluminum.

The elements in Groups 1 and 2 are all metals. They need little energy to lose their valence electrons. Therefore, the metals in Groups 1 and 2 form ions very easily. In the language of chemistry, that means they are very *reactive* metals.

Critical Thinking

4. Apply Concepts What is the charge of a nickel atom that has lost two electrons?

DETERMINING THE CHARGE ON A POSITIVE ION

Ions can have different charges. The charge on a positive ion depends on the number of electrons the atom loses. The number of valence electrons in an atom tells you the charge on the ion that the atom will form. For example, Aluminum (Al) has three valence electrons. It is a metal, so it usually loses those electrons when it forms bonds. Two changes happen after it loses the electrons:

- The second energy level becomes the outermost level.
- The Al ion has three more protons than electrons.

The Al atom becomes an Al ion with a 3+ charge. The ion is written as Al^{3+} . The equations below show why the Al ion has a 3+ charge.

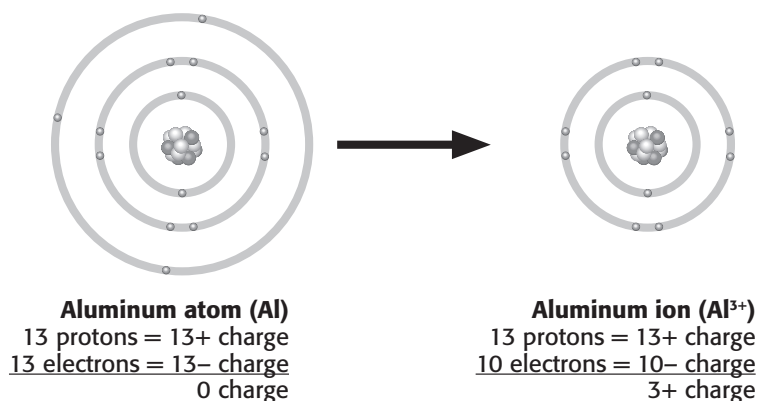

SECTION 2 Ionic Bonds *continued***How Do Negative Ions Form?**

What happens to the electrons that metal atoms lose? They can move to nonmetal atoms, such as oxygen and nitrogen. The outermost energy level of a nonmetal is almost full. It is easier for it to fill its outer energy level by gaining electrons than by losing electrons. When atoms of most nonmetals gain electrons, they give off energy. ✓

The elements in Group 17 (the halogens) are all nonmetals. Their atoms give off a lot of energy when they gain electrons. In the language of chemistry, that means that the halogens are very reactive nonmetals. They can give off heat, light, and noise when they gain electrons. ✓

DETERMINING THE CHARGE ON A NEGATIVE ION

Like positive ions, negative ions can have different charges. The charge on a negative ion depends on the number of electrons the atom gains.

You can use the number of valence electrons in an atom to learn the charge on the ion it can form. For example, an oxygen atom has six valence electrons. Oxygen tends to form ions by gaining two electrons. These two electrons fill the outermost energy level of the oxygen atom. The oxygen atom becomes a negative ion with a charge of 2^- .

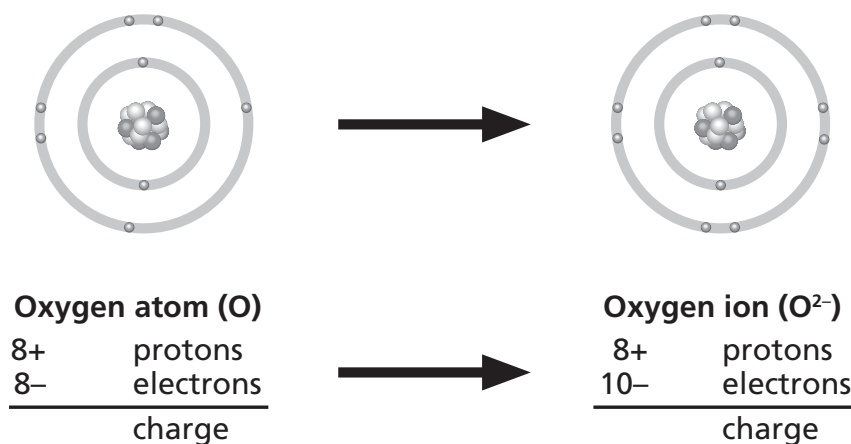

We change the names of atoms when they become negative ions by dropping the last few letters and adding *-ide*. For example, in the figure above, the oxygen atom becomes an oxide ion. Other examples of negative ions are chloride (Cl⁻) and fluoride (F⁻).

READING CHECK

5. Identify What kinds of atoms tend to gain electrons?

READING CHECK

6. Describe What does a halogen atom give off when it gains an electron?

Math Focus

7. Analyze Data In the figure to the left, write the charge of the oxygen atom and the oxygen ion. Write the charge to the left of the word "charge."

SECTION 2 Ionic Bonds *continued*

How Do Ionic Compounds Form?

Ionic bonds form because positive ions are attracted to negative ions. In order for electrons to move from one atom to another, the atoms must be very close together. When the electrons move, ions form. One ion has a positive charge. The other has a negative charge. The opposite charges on the ions cause the ions to stick together and form an ionic bond. The figure below shows an example of how an ionic bond forms. ✓

READING CHECK

8. Explain Why do ionic bonds form?

TAKE A LOOK

9. Apply Concepts If an atom of sodium combines with an atom of fluorine, what is the name of the new compound?

How It Works

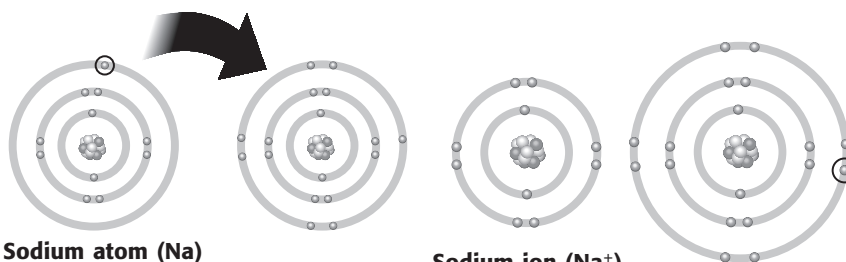

Sodium atom (Na)
 11+ protons
 11- electrons
 0 charge

Sodium ion (Na⁺)
 11+ protons
 10- electrons
 1+ charge

Chlorine atom (Cl)
 17+ protons
 17- electrons
 0 charge

Chloride ion (Cl⁻)
 17+ protons
 18- electrons
 1- charge

CALIFORNIA STANDARDS CHECK

8.3.b Students know that compounds are formed by combining two or more different elements and that compounds have properties that are different from their constituent elements.

Word Help: constituent necessary part of a whole

10. Compare How do the properties of salt compare with the properties of sodium and chlorine?

The new compound shown in the figure is called sodium chloride. The chemical symbol for sodium is Na. The chemical symbol for chlorine is Cl. Sodium chloride is written NaCl. It is the salt that many people use to flavor their food.

The figure above shows how ionic bonds form. It also shows another important feature of chemical reactions. Compare the properties of the compound sodium chloride with the properties of sodium and chlorine. They are very different! You probably would not want to put sodium or chlorine on your food. However, sodium chloride is safe to eat. The properties of a compound are always different from the properties of the elements that form it.

SECTION 2 Ionic Bonds *continued*

What Are the Characteristics of Ionic Compounds?

Ionic bonds are very strong. It takes a very large amount of energy to separate the ions in an ionic bond. Compounds formed from ionic bonds have several important features.

CRYSTALS

Ionic compounds form hard solids with flat faces and straight edges. These solids are called *crystals*. In a crystal, the positive and negative ions are found in a repeating three-dimensional pattern. This arrangement of ions is called a **crystal lattice**. ✓

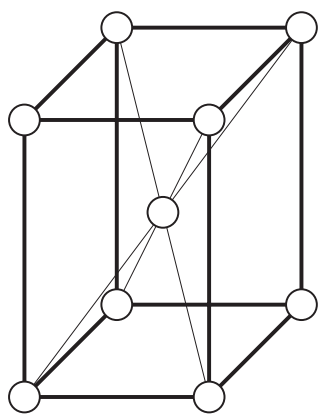

Body-centered lattice

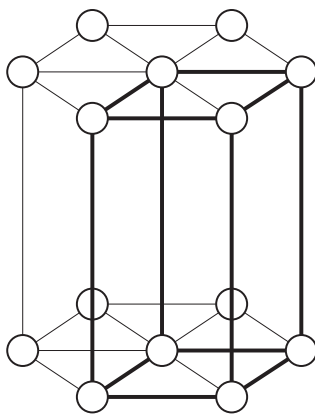

Hexagonal lattice

These two models are examples of crystal lattices.

Different ionic compounds form crystals with different properties. Some crystals are shaped like cubes. Others have more complex shapes, as shown in the figure above. Some of the crystals are clear. Other crystals, such as rubies and emeralds, are colored.

OTHER PROPERTIES

Ionic compounds form brittle solids. Something that is *brittle* breaks apart when it is hit with another object. They also have high melting points. This means they have to be heated to very high temperatures before they become liquids. Many ionic compounds also dissolve easily in water. For example, seawater tastes salty because sodium chloride and other ionic compounds are dissolved in it.

✓ READING CHECK

11. Identify What is the name given to the arrangement of ions in a crystal?

Say It

Share Observations Spread several grains of salt on a sheet of dark construction paper. Use a magnifying lens to examine the salt grains. Try to crush the grains with your fingers. Talk to your class about your observations.

Section 2 Review

8.3.a, 8.3.b, 8.3.c, 8.5.a



SECTION VOCABULARY

crystal lattice the regular pattern in which a crystal is arranged

ion a charged particle that forms when an atom or group of atoms gains or loses one or more electrons

ionic bond the attractive force between oppositely charged ions, which form when electrons are transferred from one atom to another

1. Apply Concepts Magnesium is a metal with two electrons in its outermost energy level. When it becomes an ion, what happens to its valence electrons? What happens to its charge?

2. Interpret Graphics Sulfur is a nonmetal that has six electrons in its outermost level. Using the models of a magnesium (Mg) atom and a sulfur (S) atom below, draw arrows to show the transfer of electrons.

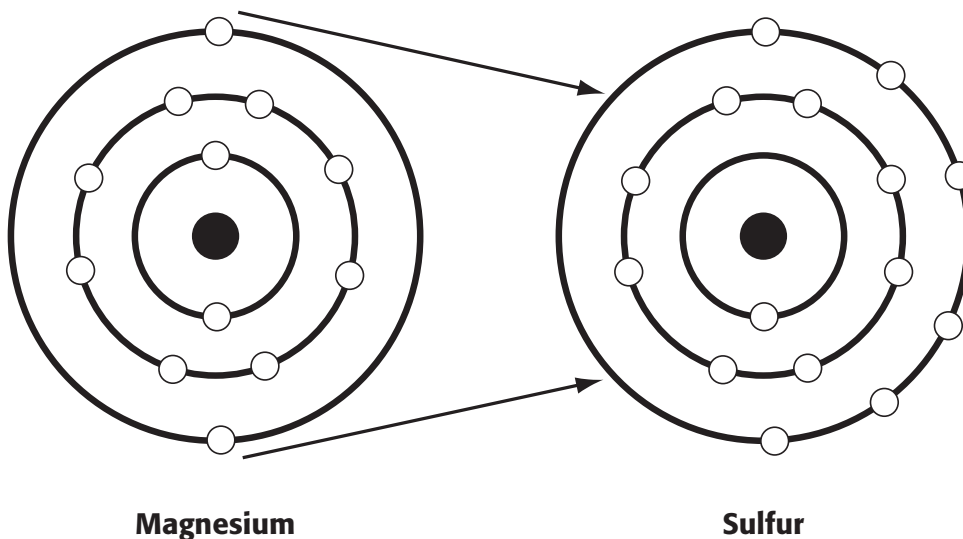

3. Predict Consequences Potassium (K) is found in Group 1. Fluorine is found in Group 7. When these atoms bind, which will form the positive ion, and which will form the negative ion? Why? Hint: Refer back to the periodic table.

4. Name What is the name given to the regular pattern in which a crystal is arranged?

CHAPTER 8 Chemical Bonding

SECTION

3

Covalent and Metallic Bonds

BEFORE YOU READ

After you read this section, you should be able to answer these questions:

- How are covalent bonds formed?
- What are molecules?
- What are metallic bonds?
- How does bonding affect a metal's properties?



California Science Standards

8.3.a, 8.3.b

What Are Covalent Bonds?

Another type of bond is a covalent bond. A **covalent bond** forms when atoms share electrons. Covalent bonds most often form between atoms of nonmetals. Remember that most nonmetals can fill the outermost energy level by gaining an electron. When a covalent bond forms, both atoms are able to fill their outermost energy level. They do this by sharing electrons between the two atoms. ✓

Hydrogen is one example of an atom that bonds covalently. A hydrogen atom has one electron in its outermost level. Two hydrogen atoms can come together and share their electrons. This fills the first energy level of both atoms. The electrons move around both hydrogen nuclei. The protons and the shared electrons attract one another. This attraction holds the atoms together.

By sharing electrons in a covalent bond, each hydrogen atom (the smallest atom) has a full outermost energy level containing two electrons.

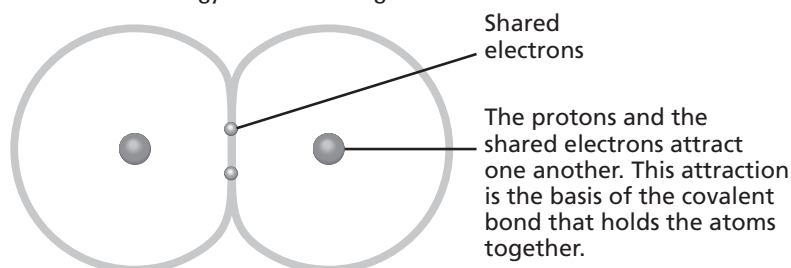
**What Are Molecules?**

Atoms that join with each other by covalent bonds form particles called **molecules**. Most molecules are made of atoms of two or more elements. The atoms share electrons. In the figure above, two hydrogen atoms have formed a covalent bond. The result is a hydrogen molecule. ✓



Compare As you read, make a chart comparing covalent bonds and metallic bonds.



1. Explain How do electrons behave in covalent bonds?



2. Identify What type of bond joins the atoms in molecules?

SECTION 3 Covalent and Metallic Bonds *continued***PROPERTIES OF MOLECULES**

Remember that an atom is the smallest piece of an element that still has the properties of that element. In the same way, a molecule is the smallest piece of a covalently bonded compound that has the properties of that compound. This means that if a molecule is broken down, it will no longer have the properties of that compound.

Most covalently bonded substances have low melting and boiling points. (Water is an exception to this.) Many are gases at room temperature. When a substance with covalent bonds forms a solid, the solid tends to be soft.

How Can You Model a Covalent Bond?

An *electron-dot diagram* is a model that shows only the valence electrons of an atom. The figure below shows the electron-dot diagrams for the elements in the second row of the periodic table.

Electron-Dot Diagrams	Li·	Be·	B·	·C·	:N·	:O·	:F·	:Ne:
	Li·	Be·	B·	·C·	:N·	:O·	:F·	:Ne:

TAKE A LOOK**3. Apply Concepts**

Hydrogen has one valence electron. Draw an electron-dot diagram of a hydrogen atom.

Electron-dot diagrams are used to show how atoms bond in molecules. In the diagram below, you can see the pairs of electrons that form the covalent bonds in a water molecule.

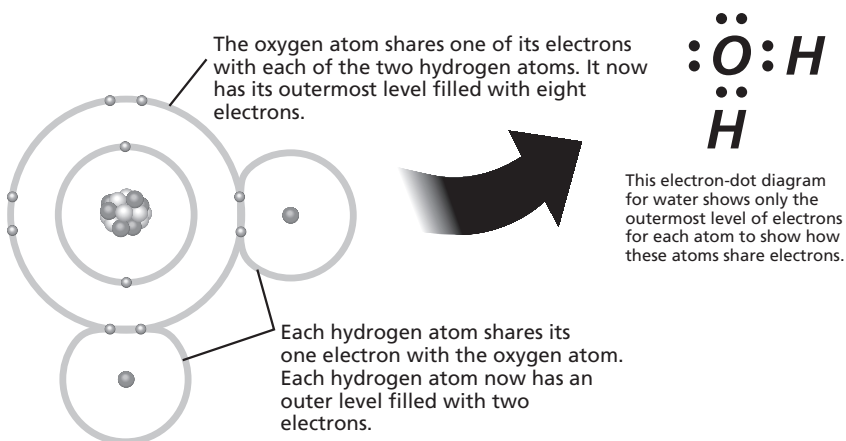
**Critical Thinking**

4. Apply Concepts Draw the electron-dot diagram that shows how two hydrogen atoms bond with a covalent bond.

SECTION 3 Covalent and Metallic Bonds *continued***What Kinds of Molecules Can Form?**

Molecules contain at least two atoms bonded by covalent bonds. The simplest molecules are made up of only two bonded atoms. They are called *diatomic molecules*. If the two atoms are of the same element, the substance is known as a *diatomic element*. The oxygen and nitrogen in the air that we breathe are both diatomic elements. ✓

In a molecule of any diatomic element, each of the shared electrons is counted as a valence electron for both atoms. So, both atoms of the molecule have filled outermost energy levels.

Electron-Dot Diagrams for Chlorine, Oxygen, and Nitrogen Gas**COUNTING COVALENT BONDS**

We have seen how atoms can share one or more pairs of electrons. The oxygen atom in water shares two pairs of electrons, one pair with each hydrogen atom. We say that the oxygen atom in a water molecule forms two covalent bonds.

The number of shared pairs of electrons tells you the number of covalent bonds in a molecule. In the figure above, you counted the number of electron pairs shared in molecules of chlorine, oxygen, and nitrogen. In a chlorine molecule, there is one covalent bond. There are two covalent bonds in an oxygen molecule and three in a nitrogen molecule.

Many molecules are more complex than the molecules in the figure. As you may suspect, these molecules have many covalent bonds.

READING CHECK

5. Identify What type of molecule is made of two of the same atom?

TAKE A LOOK

6. Count How many electrons are around each chlorine atom, each oxygen atom, and each nitrogen atom? (Remember, the electrons that are shared count for each atom.)

Chlorine: _____

Oxygen: _____

Nitrogen: _____

7. Count How many pairs of electrons are shared in each molecule?

Chlorine: _____

Oxygen: _____

Nitrogen: _____

Critical Thinking

8. Apply Concepts How many covalent bonds does phosphorus (P) form in the molecule shown below:



SECTION 3 Covalent and Metallic Bonds *continued*

MORE COMPLEX MOLECULES

Many molecules are much larger and more complex than diatomic molecules or water. Complex molecules have many atoms joined by covalent bonds. Complex molecules make up many important and familiar substances, such as gasoline, soap, plastics, proteins, and sugars. In fact, most of the substances that make up your body are complex molecules!

Carbon (C) atoms are the basis of many complex molecules. Carbon has four valence electrons. To fill its outer energy level, a carbon atom needs to gain four electrons. Therefore, carbon atoms can form four covalent bonds. Carbon atoms can form bonds with other carbon atoms. They also can bond to atoms of other elements, such as oxygen, hydrogen, and nitrogen. Most of the molecules that carbon forms are very complex.

Model of an Octane Molecule Found in Gasoline

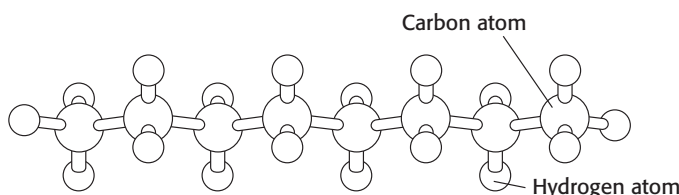

TAKE A LOOK

9. Count How many covalent bonds does an atom of carbon form in this molecule?

What Are Metallic Bonds?

The bonding in metals is different from the bonding we have discussed. Metals are substances like copper, iron, silver, and nickel. A **metallic bond** is a bond formed by the attraction between positively charged metal ions and the electrons around the ions. ✓

Valence electrons from outer shells of metal atoms

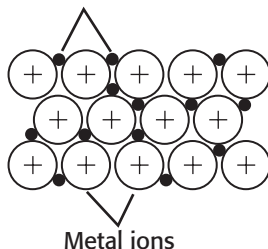

The bonding in metals is a result of the closeness of many metal atoms. Their outermost energy levels overlap. Because of the overlapping, metallic bonds form and extend throughout the metal in all directions. The valence electrons can move throughout the metal. The electrons keep the ions together and cancel the positive charge of the ions. ✓

READING CHECK

10. Describe How is a metallic bond formed?

READING CHECK

11. Explain How do valence electrons behave in a metallic bond?

SECTION 3 Covalent and Metallic Bonds *continued***What Are the Properties of Metals?**

You probably know whether something is metal as soon as you look at it. Most metals are very shiny like gold, silver, copper, nickel, and platinum. Metals have other characteristic properties, too.

CONDUCTING ELECTRIC CURRENT

Metallic bonding allows metals to conduct electricity. Metals are used to make wires. When one end of the wire is attached to an electrical source, the valence electrons are free to move throughout the wire and do work. They can light a bulb or power a radio. ✓

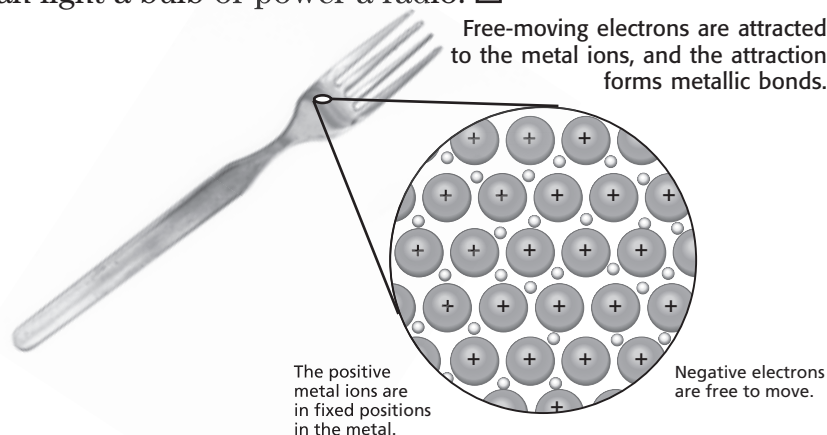
**READING CHECK**

12. Explain Why can a wire conduct an electric current when it is connected to an electrical source?

RESHAPING METALS

The atoms in metals can be rearranged easily because the electrons move around freely. The valence electrons of metals are constantly moving around the metal ions. This movement maintains the metallic bonds. So, no matter how the shape of the metal is altered, it won't break. This is why metals can so easily change their shape. Two properties describe a metal's ability to be reshaped:

- *Ductility* is the ability to be shaped into long, thin wires.
- *Malleability* is the ability to be hammered into thin sheets. ✓

Ductility and malleability are the properties that make many metals useful for people. Copper can be stretched to make electrical wires. Aluminum can be pounded to form sheets of foil. Silver and gold can be mixed with other metals and bent to form jewelry and fill cavities in teeth.

READING CHECK

13. Define What does ductility mean? What does malleability mean?

Section 3 Review

8.3.a, 8.3.b 

SECTION VOCABULARY

covalent bond a bond formed when atoms share one or more pairs of electrons
metallic bond a bond formed by the attraction between positively charged metal ions and the electrons around them

molecule a group of atoms that are held together by chemical forces; a molecule is the smallest unit of matter that can exist by itself and retain all of a substance's chemical properties

1. Apply Ideas The following is a list of elements: gold, carbon, oxygen, aluminum, copper, and fluorine. In the table below, list each under the correct heading.

Forms covalent bonds	Forms metallic bonds

2. Apply Concepts Nitrogen has five valence electrons, and hydrogen has one. An ammonia molecule has one nitrogen atom and three hydrogen atoms. Draw an electron-dot diagram for a molecule of ammonia.

3. Apply Concepts In addition to conducting electricity, metals conduct heat quickly. Substances with covalent bonds are not good conductors of heat or electricity. Which type of substance would you use as insulating material for a hot mitt?

Which type of substance would you use as a heating coil in an electric toaster?

4. Make Inferences What happens to the properties of oxygen when oxygen bonds with hydrogen to form water?

5. Identify List three properties of metals that are caused by metallic bonding.

CHAPTER 9 Chemical Reactions

SECTION 1

Forming New Substances

BEFORE YOU READ

After you read this section, you should be able to answer these questions:

- What is a chemical reaction?
- What are exothermic reactions?
- What are endothermic reactions?



California Science Standards

8.3.b, 8.5.a, 8.5.c

What Is a Chemical Reaction?

Chemical reactions happen around you all the time. Wood burns and turns to ash. Rust forms on iron. Bread dough rises. These are all chemical reactions.

A **chemical reaction** happens when substances break apart or combine to form one or more new substances. New substances form when bonds break and new bonds form. The chemical properties of the new substances are different from those of the original substances. ✓

STUDY TIP

Compare and Contrast As you read this section, make a chart comparing and contrasting endothermic and exothermic reactions.

What Are the Signs of a Chemical Reaction?

There are several ways to tell that a chemical reaction has happened. Sometimes, you can see the new substance that forms during the reaction. For example, during some chemical reactions, a precipitate forms. A **precipitate** is a solid substance that forms in a solution. The figure below shows some of the signs that a chemical reaction is happening.

READING CHECK

1. Define Write a definition for chemical reaction in your own words.

Some chemical reactions produce gas. For example, nitrogen dioxide gas is produced when copper reacts with nitric acid.

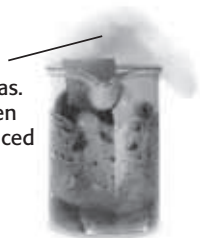

Some chemical reactions produce a precipitate. For example, solid silver chromate forms when potassium chromate solution is added to silver nitrate solution.



Some chemical reactions give off energy. For example, burning wood gives off light and heat energy. Other chemical reactions take in energy.



During some chemical reactions, a color change happens. For example, the chemical reaction between the blue dye in jeans and bleach will cause the jeans to change color.

TAKE A LOOK

2. Identify Give three signs that can indicate that a chemical reaction is happening.

SECTION 1 Forming New Substances *continued***CALIFORNIA STANDARDS CHECK**

8.3.b Students know that compounds are formed by combining two or more different elements and that compounds have properties that are different from their constituent elements.

Word Help: **constituent** necessary part of a whole

3. Explain What happens to the chemical properties of substances during a chemical reaction?

CHANGING CHEMICAL PROPERTIES

Even if you see some of the signs of a chemical reaction, it does not always mean that a reaction is happening. For example, a gas (water vapor) is given off when water boils. However, remember that boiling is a physical change. It is not a chemical reaction.

How can you be sure that a chemical reaction is happening? The best way is to look at the chemical properties of the substance that forms. The new substances that form during chemical reactions always have different chemical properties than the original substances. The figure below shows an example of how chemical properties can change during a chemical reaction.

This sulfuric acid is a clear liquid.



This sugar is a white solid.



When sulfuric acid reacts with sugar, new substances with different properties form. Carbon is a black solid. Water vapor is a colorless gas.

How Do New Substances Form?

Chemical reactions happen when chemical bonds are broken and formed. A *chemical bond* is a force that holds two atoms together in a molecule. During a chemical reaction, some of the bonds in the original molecule break. New bonds form to produce a new substance. ✓

Remember that molecules are always moving. If the molecules in a substance bump into each other with enough energy, some of the bonds in the molecules can break. The atoms can form new bonds with different atoms. A new substance forms. The figure on the next page shows an example of how new substances can form.

READING CHECK

4. Describe What happens to chemical bonds during a chemical reaction?

SECTION 1 Forming New Substances *continued*

Hydrogen and chlorine are diatomic molecules. Diatomic molecules are made of two atoms bonded together. In order for hydrogen to react with chlorine, the bonds between the atoms must break.

New bonds can form between hydrogen atoms and chlorine atoms. A new substance, hydrogen chloride, forms. Hydrogen chloride is also a diatomic molecule.

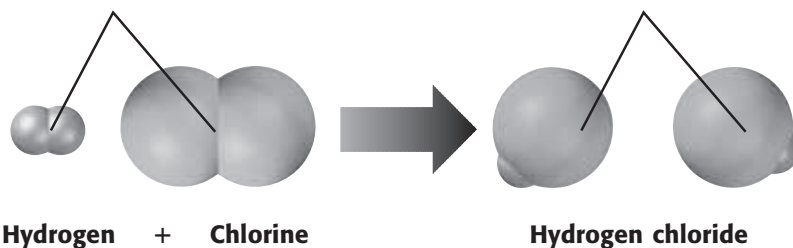
**What Happens to Energy During a Reaction?**

Remember that all chemical reactions involve breaking and forming bonds. It takes energy to break a chemical bond. Energy is given off when a chemical bond forms. During some reactions, a lot of energy is released when new bonds form. More energy is given off than is used to break the bonds in the original substances. These chemical reactions give off energy.

During other reactions, very little energy is released when new bonds form. The energy that is given off is less than the amount needed to break the bonds in the original substances. These chemical reactions take in energy.

EXOTHERMIC REACTIONS

A reaction that gives off energy is an **exothermic reaction**. *Exo* means “go out” or “exit.” *Thermic* means “heat” or “energy.” During an exothermic reaction, energy is released into the surroundings.

Exothermic reactions can give off energy in several forms. Some exothermic reactions give off electricity. For example, the exothermic reaction in a battery produces electricity that can make a flashlight work. Some exothermic reactions give off heat. Some give off light. Many give off energy in several forms. For example, wood burning is an exothermic reaction. It gives off both heat and light.

TAKE A LOOK

5. Identify Hydrogen and chlorine react to produce hydrogen chloride. What bonds are broken and what bonds are formed during this reaction?

**CALIFORNIA STANDARDS CHECK**

8.5.c Students know chemical reactions usually liberate heat or absorb heat.

Word Help: liberate to release; to set free

6. Explain What can happen to energy during a chemical reaction?

SECTION 1 Forming New Substances *continued*

 **Say It**

Discuss In a small group, talk about different chemical reactions that affect your life. Are these reactions exothermic or endothermic? How do you know?

Critical Thinking

7. Apply Concepts What probably happened to the temperature of the air, the flask, and the wood during the reaction? Explain your answer.

ENDOTHERMIC REACTIONS

A reaction that takes in energy is an **endothermic reaction**. *Endo* means “go in.” During an endothermic reaction, energy is taken in from the surroundings.

Like exothermic reactions, the energy in endothermic reactions can be in several forms. Some reactions take in light energy. For example, plants use light energy to make food during the process of *photosynthesis*. Photosynthesis is an endothermic reaction.

Some endothermic reactions take in heat energy. For example, in the figure below, the reaction in the flask is endothermic. There were a few drops of water between the wood and the flask. The reaction in the flask absorbed energy from the water, causing it to freeze. The reaction also absorbed energy from the air, the flask, and the wood.



The chemical reaction happening in the flask is endothermic. It absorbs energy from the flask, the wood, and the air.

There were a few drops of water between the wood and the flask. The reaction in the flask absorbed energy from the water and caused it to freeze.

Where Does the Energy Go?

The **law of conservation of energy** states that energy cannot be created or destroyed. However, energy can change forms. Energy can move from one object to another. For example, the chemical reaction between gasoline and oxygen in a car engine makes parts of the engine move. The energy changes from chemical energy to *kinetic energy*, the energy of motion. ✓

The energy given off in an exothermic reaction was once contained in the chemical bonds in the original substances. The energy taken in during an endothermic reaction is stored in the bonds in the new substances.

 **READING CHECK**

8. Define Write your own definition for the law of conservation of energy.

Section 1 Review

8.3.b, 8.5.a, 8.5.c



SECTION VOCABULARY

chemical reaction the process by which one or more substances change to produce one or more different substances

endothermic reaction a chemical reaction that requires heat

exothermic reaction a chemical reaction in which heat is released to the surroundings

law of conservation of energy the law that states that energy cannot be created or destroyed but can be changed from one form to another

precipitate a solid that is produced as a result of a chemical reaction in solution

1. Compare How are exothermic reactions different from endothermic reactions?

2. Explain What happens to energy when a chemical bond forms? What happens to energy when a chemical bond is broken?

3. List Give one example of an exothermic reaction and one example of an endothermic reaction.

4. Apply Concepts Explain why water boiling is not a chemical reaction, even though it releases a gas. Use the words *chemical bond* in your answer.

5. Infer A scientist mixes substance A and substance B in a beaker. Neither substance A nor substance B can conduct electricity. The material in the beaker changes color, and the beaker becomes very hot. The material left in the beaker conducts electricity. Has a chemical reaction occurred? Explain your answer.

CHAPTER 9 Chemical Reactions

SECTION

2

Chemical Formulas and Equations

California Science
Standards

8.3.f, 8.5.b

BEFORE YOU READ

After you read this section, you should be able to answer these questions:

- How do chemical formulas show the elements in a substance?
- How do chemical equations show what happens during a chemical reaction?
- How can you balance a chemical equation?

STUDY TIP

Ask Questions As you read this section, make a list of questions that you have. Talk about your questions with a small group. When you figure out the answers to your questions, write them in your notebook.

READING CHECK

1. Identify What are two things that are shown by a chemical formula?

Math Focus

2. Calculate How many oxygen atoms are in three molecules of water?

What Is a Chemical Formula?

We use letters to form words. We put words together to form sentences. In the same way, scientists use symbols to form chemical formulas that describe different substances. They put chemical formulas together to show how chemical reactions happen.

Remember that substances are formed from different elements. Each element has its own chemical symbol. You can find the symbol for an element in the periodic table. Scientists combine the symbols for different elements into chemical formulas. A **chemical formula** shows which elements are found in a substance. It also shows how many atoms of each element are found in a molecule of the substance. ✓

In order to learn how chemical formulas work, let's look at an example. The chemical formula for water is H_2O . This formula means that a molecule of water is made of two hydrogen (H) atoms and one oxygen (O) atom.

The small 2 in the formula is a subscript. A *subscript* is a number that tells you how many atoms of an element are in a molecule. Subscripts are always written below and to the right of the symbol for an element. If there is no subscript next to an element's chemical symbol, only one atom of the element is found in the substance.



Water A molecule of water contains 2 hydrogen (H) atoms and 1 oxygen (O) atom.



Oxygen A molecule of oxygen is made of 2 oxygen (O) atoms.

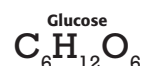

Glucose A molecule of glucose contains 6 carbon (C) atoms, 12 hydrogen (H) atoms and 6 oxygen (O) atoms.

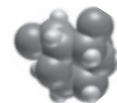

SECTION 2 Chemical Formulas and Equations *continued***FORMULAS FOR COVALENT COMPOUNDS**

In many cases, the name of a covalent compound tells you how to write its chemical formula. This is because the names of many covalent compounds use prefixes. These prefixes represent numbers. For example, the prefix *di-* means “two.” The prefixes tell you how many atoms of an element are found in a substance. The tables below show the meanings of different prefixes.

Prefix	Number
mono-	1
di-	2
tri-	3
tetra-	4
penta-	5

Prefix	Number
hexa-	6
hepta-	7
octa-	8
nona-	9
deca-	10

Carbon dioxide



The **absence of a prefix** indicates one carbon atom.
The prefix ***di-*** indicates two oxygen atoms.

Dinitrogen monoxide



The prefix ***di-*** indicates two nitrogen atoms.
The prefix ***mono-*** indicates one oxygen atom.

FORMULAS FOR IONIC COMPOUNDS

Remember that ions have electrical charges. However, when ions combine to form a substance, the substance does not have an electrical charge. Therefore, the formula for an ionic compound must have subscripts that make the charges of the ions balance. To write a formula for an ionic compound, make sure the charges of all the ions add up to zero. The figure below shows some examples of how to name ionic compounds.

Sodium chloride



A sodium ion has a **1+ charge**.
A chloride ion has a **1- charge**.
One sodium ion and one chloride ion have an **overall charge of (1+) + (1-) = 0**.

Magnesium chloride



A magnesium ion has a **2+ charge**.
A chloride ion has a **1- charge**.
One magnesium ion and two chloride ions have an **overall charge of (2+) + 2(1-) = 0**.

Critical Thinking

3. Apply Concepts Write a name for the covalent compound whose chemical formula is H_2S .

**CALIFORNIA STANDARDS CHECK**

8.3.f Students know how to use the periodic table to identify elements in simple compounds.

4. Write a Formula Write the chemical formula for the compound silicon tetrachloride. You can use a periodic table to help you.

TAKE A LOOK

5. Identify What is the charge on the Fe ion in the ionic compound FeCl_3 ?

SECTION 2 Chemical Formulas and Equations *continued*

How Are Chemical Formulas Used to Write Chemical Equations?

Scientists use chemical equations to describe reactions. A **chemical equation** uses chemical symbols and formulas as a short way to show a chemical reaction. A chemical equation shows that the numbers and kinds of atoms are the same before and after a reaction. ✓

The starting materials in a chemical reaction are the **reactants**. The substances that form during the reaction are the **products**. In a chemical equation, the reactants and products are written using chemical formulas. Scientists use a plus sign to separate the formulas of two or more reactants or products. An arrow points from the formulas of the reactants to the formulas of the products.

READING CHECK

6. Define What is a chemical equation?

TAKE A LOOK

7. Identify List the reactants and the products of the reaction in the figure. Use chemical formulas in your answer.

reactants: _____

products: _____

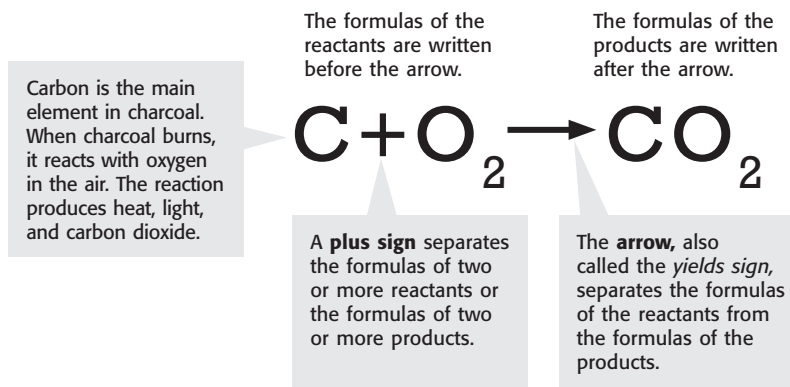
**CHECKING SYMBOLS**

When you write a chemical formula, it is important that you check to make sure that it is correct. If you use the wrong formula or symbol in an equation, the equation will not describe the correct reaction. Even a small mistake can make a big difference. ✓

As an example, consider the three formulas Co, CO, and CO₂. These formulas look very similar. However, the substances they represent are very different. Co is the symbol for the element cobalt, a hard, bluish-grey metal. CO is the formula for carbon monoxide, a colorless, poisonous gas. CO₂ is the formula for carbon dioxide, a colorless gas that living things give off when they breathe.

READING CHECK

8. Explain Why is it important to check to make sure that your chemical formulas are correct?

SECTION 2 Chemical Formulas and Equations *continued***CONSERVING MASS**

The **law of conservation of mass** states that mass can not be created or destroyed during a chemical reaction. The total mass of the reactants in a chemical reaction is the same as the total mass of the products. You can use this law to help you figure out how to write a chemical equation.

During a chemical reaction, atoms are not lost or gained. Every atom in the reactants becomes part of the products. Therefore, in a chemical equation, the numbers and kinds of atoms in the reactants and products must be equal. In other words, the chemical equation must be *balanced*.

HOW TO BALANCE A CHEMICAL EQUATION

Follow these steps to write a balanced equation for $\text{H}_2 + \text{O}_2 \longrightarrow \text{H}_2\text{O}$.

- 1** Count the atoms of each element in the reactants and the products. Here, you can see that there are more oxygen atoms in the reactants than in the products. Therefore, the chemical equation is not balanced.

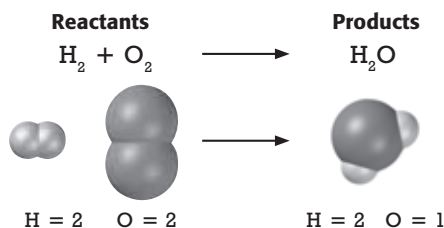

- 2** Add coefficients to balance the atoms of oxygen. There are two atoms of oxygen in the reactants. Place the coefficient 2 in front of the products to give two atoms of oxygen in the products. Then, count the atoms again. Now, the hydrogen atoms are not balanced.

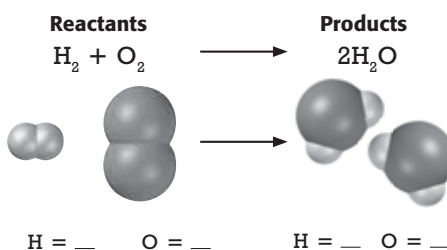

- 3** Add coefficients to balance the atoms of hydrogen. Add the coefficient 2 to the H_2 reactant to give four atoms of hydrogen in the reactants. Then, count the atoms again to double-check your work.

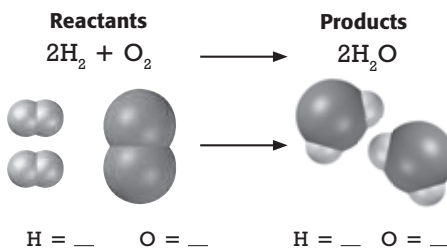

CALIFORNIA STANDARDS CHECK

8.5.b Students know the idea of atoms explains the conservation of matter: In chemical reactions the number of atoms stays the same no matter how they are arranged, so their total mass stays the same.

9. Explain How can you use the law of conservation of mass to help you balance a chemical equation?

TAKE A LOOK

10. Identify Fill in the blank lines in the figure to show how many atoms of each element are in the reactants and the products.

Section 2 Review

8.3.f, 8.5.b 

SECTION VOCABULARY

chemical equation a representation of a chemical reaction that uses symbols to show the relationship between the reactants and the products

Wordwise The root *equ* means “even” or “equal.”

chemical formula a combination of chemical symbols and numbers to represent a substance

law of conservation of mass the law that states the mass cannot be created or destroyed in ordinary chemical and physical changes

product a substance that forms in a chemical reaction

reactant a substance or molecule that participates in a chemical reaction

1. Compare How is a chemical equation different from a chemical formula?

2. Identify Fill in the blank spaces in the table.

Chemical equation	Number of atoms in the reactants	Number of atoms in the products	Is the equation balanced?
$\text{Na} + \text{Cl}_2 \rightarrow \text{NaCl}$	Na = Cl =	Na = Cl =	
$\text{HCl} + \text{NaOH} \rightarrow \text{NaCl} + \text{H}_2\text{O}$	H = Cl = Na = O =	H = Cl = Na = O =	
$2\text{Sb} + 3\text{I}_2 \rightarrow 2\text{SbI}_3$	Sb = I =	Sb = I =	

3. Describe Give the names of the covalent compounds listed below.

SiO_2 _____

SbI_3 _____

4. Explain Why can't you change the subscripts in a formula in order to balance a chemical equation?

5. Compare How does the mass of reactants in a reaction compare with the mass of the products?

CHAPTER 10 Chemical Compounds

SECTION 1 **Ionic and Covalent Compounds**

BEFORE YOU READ

After you read this section, you should be able to answer these questions:

- What gives a compound its physical properties?
- What are the ionic compounds?
- What are the covalent compounds?



California Science Standards

8.3.b, 8.3.c, 8.7.c

What Are Ionic and Covalent Compounds?

Many things are made of combinations of elements called *compounds*. Sugar, salt, gasoline, and chalk are all compounds because they have atoms of more than one element. But how are they alike and how are they different?

Scientists *classify*, or group, chemical compounds by the kinds of chemical bonds they have. A **chemical bond** joins atoms together to form compounds. The compounds are grouped by their bonding as either *ionic* or *covalent*.

Bonding happens between valence electrons of different atoms. *Valence electrons* are electrons in the outermost energy level of an atom. The type of compound that forms depends on what happens to the valence electrons. ✓

What Makes a Compound Ionic?

An ionic bond is an attraction between ions that have opposite charges. Compounds that have ionic bonds are called **ionic compounds**.

Ionic compounds can be formed by the chemical reaction between a metal and a nonmetal. Metal atoms become positively charged ions when electrons move from the metal atoms to the nonmetal atoms. When the electrons move, the nonmetal atoms gain a negative charge. ✓



A sodium atom has lost an electron to a chlorine atom. The result is a positively charged sodium ion and a negatively charged chlorine ion. The attraction of the ions is called an ionic bond.

STUDY TIP

Work in Pairs Make flash cards with all of the vocabulary words in this section. Also make flash cards of the words in *italics* in this section.

On the other side of the card, write the definition of the word. Practice saying the words and their definitions.

READING CHECK

1. Identify What determines the type of compound that forms when atoms bond?

READING CHECK

2. Describe What kind of ions do metals form? What kind of ions do nonmetals form?

SECTION 1 Ionic and Covalent Compounds *continued*

What Are the Properties of an Ionic Compound?

Strong bonds are formed in ionic compounds because of the attraction between oppositely charged ions. These bonds make ionic compounds different from other compounds. There are several properties that tell you a compound is ionic.

IONIC COMPOUNDS ARE BRITTLE

Ionic compounds tend to be brittle at room temperature. That means they break apart when hit. They break because their ions are arranged in a pattern that happens over and over again. The pattern is called a *crystal lattice*. Each ion in a lattice bonds to the ions around it that have the opposite charge. ✓

✓ **READING CHECK**

3. Describe What is a crystal lattice?

When you hit an ionic compound, the ions move and the pattern changes. Ions that have the same charge line up and repel each other. That makes the crystals break.

Sodium chloride crystals (shown below) all have a regular cubic shape because of the way sodium and chloride ions are arranged in the crystal lattice.

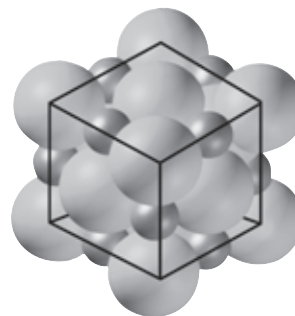

Sodium chloride crystals all have a regular cubic shape because of the way sodium and chloride ions are arranged.

✓ **READING CHECK**

4. Explain What causes ionic compounds to have high melting points?

IONIC COMPOUNDS HAVE A HIGH MELTING POINT

Because of the strong bonds that hold ions together, ionic compounds don't melt easily. They have a high melting point. That is the reason that most ionic compounds are solids at room temperature. For example, sodium chloride must be heated to 801°C before it will melt. ✓

SECTION 1 Ionic and Covalent Compounds *continued***IONIC COMPOUNDS ARE SOLUBLE**

Many ionic compounds are highly *soluble* in water. That means they dissolve easily in water. Water molecules attract each of the ions of an ionic compound and pull the ions away from each other.

IONIC COMPOUNDS CONDUCT ELECTRICITY

The solution that forms when an ionic compound dissolves in water can conduct an electric current. It conducts electricity because its ions are now free to move freely past each other. When ionic compounds are solids, their ions are not free to move. They will not conduct an electric current. ✓

In the pictures below, the pure water does not conduct an electric current. However, the solution of salt water conducts a current, so the bulb lights up.



Pure water does not conduct an electric current.



However, the solution of salt water does conduct an electric current, so the bulb lights up.

What Makes a Compound Covalent?

Many of the compounds in your body are covalent compounds. **Covalent compounds** form when atoms share electrons. The bond that forms when atoms share electrons is called a *covalent bond*. Atoms share electrons to fill their outermost energy level. This forms a group of atoms, each having a full valence shell.

The group of atoms that make up a covalent compound is called a *molecule*. A molecule is the smallest particle that you can divide a compound into and still have the same compound. For example, if you break water down further, it isn't water anymore. It is hydrogen and oxygen.

 **READING CHECK**

5. Explain Why do ionic compounds dissolved in water conduct an electric current?

**CALIFORNIA STANDARDS CHECK**

8.3.b Students know that compounds are formed by combining two or more different elements and that compounds have properties that are different from their constituent elements.

Word Help: **constituent** necessary part of a whole

6. Think and Explain How is the electrical conductivity of sodium chloride different from the conductivity of sodium metal?

SECTION 1 Ionic and Covalent Compounds *continued*

What Are the Properties of Covalent Compounds?

The properties of covalent compounds are very different from the properties of ionic compounds.

SOME COVALENT COMPOUNDS DO NOT DISSOLVE IN WATER

Before you use salad dressing, you must shake the bottle to mix the oil and the water in the dressing. The oil and water separate because the oil has covalent compounds that are not soluble in water.

Covalent compounds that are not soluble in water contain molecules that are not attracted by water molecules. So, the water molecules stay together and the oil molecules stay together. ✓

READING CHECK

7. Explain Why don't some covalent compounds dissolve in water?

COVALENT COMPOUNDS HAVE LOW MELTING POINTS

The forces of attraction between molecules in solid covalent compounds are much weaker than those that hold ionic solids together. It takes less heat to separate the molecules of covalent compounds. So, these compounds have much lower melting and boiling points than ionic compounds do.

COVALENT COMPOUNDS DO NOT CONDUCT ELECTRICITY WELL

Most covalent compounds that dissolve in water form solutions that have uncharged molecules. For example, sugar is a covalent compound that dissolves in water. But, it does not form ions. So a solution of sugar and water does not conduct an electric current as shown in the figure below. ✓



A solution of sugar, a covalent compound, in water does not conduct an electric current. This is because no ions form.

However, some covalent compounds do form ions when they dissolve in water. Many acids, for example, form ions in water. Acidic solutions conduct electricity.

READING CHECK

8. Explain A covalent compound is dissolved in water. The solution does not conduct an electric current. Why not?

Section 1 Review

8.3.b, 8.3.c, 8.7.c



SECTION VOCABULARY

chemical bond the combining of atoms to form molecules or compounds**covalent compound** a chemical compound that is formed by the sharing of electrons**ionic compound** a compound made of oppositely charged ions

1. Compare Compare the melting points of ionic compounds to those of covalent compounds.

2. Make Inferences Examine the table below. Use the information in the table to help you decide if the compound is ionic or covalent. Write *ionic* or *covalent* in the box next to each compound

Compound	Melting point	Ionic or covalent
A	low	
B	low	
C	high	
D	high	

3. Describe Why do ionic compounds tend to be brittle?

4. Explain Solid crystals of ionic compounds do not conduct an electric current. Why does the solution conduct electricity when the crystals dissolve in water?

5. Describe Describe how a metal and a nonmetal can combine by forming an ionic bond.

CHAPTER 10 Chemical Compounds

SECTION

2

Acids and Bases

California Science
Standards

8.5.e

BEFORE YOU READ

After you read this section, you should be able to answer these questions:

- What are the properties of acids?
- What are the properties of bases?



Graphic organizer In your science notebook, create two Idea Wheels, one about acids and one about bases.

TAKE A LOOK

1. Explain How is a hydronium ion formed?

What Are Acids?

Many of the foods we eat contain acid. For example, lemons, vinegar, grapes, and soft drinks are *acidic*, or acid-containing foods. But acids are not just in foods. You can find acid in car batteries, in paper, and even in your stomach. An **acid** is any compound that increases the number of hydronium ions (H_3O^+) when dissolved in water. The figure below shows how the hydronium ion forms.

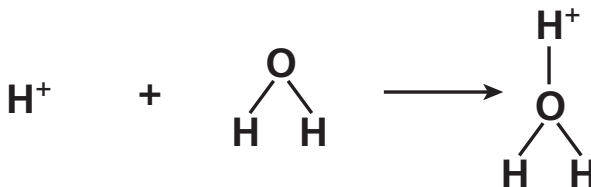
Formation of a Hydronium Ion

Hydrogen ion plus water make a hydronium ion.

What Are the Properties of Acids?

The hydrogen ions in acids are what give acids their special properties. There are several properties that give us a clue that a substance is an acid.

SOUR TASTE

Have you ever bitten into a lemon? It probably tasted sour and made your mouth pucker up. Foods that have a sour taste usually contain acid. In fact, the word *acid* means “sour” in Latin. The taste of lemons, limes, and other citrus fruits comes from citric acid. But, remember that you should never taste, touch, or smell an unknown chemical.

Many acids are dangerous because they are *corrosive*. That means that they destroy body tissue, clothing, and many other things. Most acids are also poisonous.



2. Identify What kind of taste do acids have?

SECTION 2 Acids and Bases *continued***COLOR CHANGE OF INDICATORS**

We can use colored chemicals to tell us if a solution is an acid or a base. A substance that changes color in the presence of an acid or base is an **indicator**. For example, if you squeeze lemon juice into a cup of tea, it changes color. The tea shows that the lemon juice has increased the acidity.

A solution called *bromthymol blue* is an indicator used by scientists. If you add acid to bromthymol blue, it changes from pale blue to yellow. It *indicates*, or shows, the presence of acid. Scientists also use a special kind of paper called *litmus paper* as an indicator. The paper contains the substance litmus. The paper comes in blue or red. When you add acid to blue litmus paper, it turns red.

REACTION WITH METALS

Acids react with some metals to make hydrogen gas. For example, when hydrochloric acid reacts with the metal zinc, the product is hydrogen gas. This is the chemical equation for that reaction:

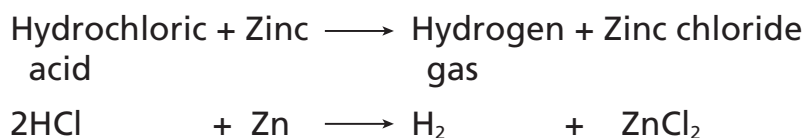

In this reaction, zinc takes the place of hydrogen in hydrochloric acid. This reaction happens because zinc is a reactive metal. But other metals, such as silver or gold, do not react easily. For example, if silver were used in the reaction above, no hydrogen gas would be produced.

ELECTRICAL CONDUCTIVITY

When acids dissolve in water, they break apart and form ions in the solution. The ions make it possible for the solution to conduct an electric current. ✓

A car battery is an example of how an acid can be used to produce an electric current. The acid that is in a car battery conducts an electric current to help start the car's engine.

**CALIFORNIA STANDARDS CHECK**

8.5.e Students know how to determine whether a solution is acidic, basic, or neutral.

3. Describe What is an indicator?

4. Name What are two kinds of indicators used by scientists?

TAKE A LOOK

5. Identify What forms when zinc reacts with hydrochloric acid?

**READING CHECK**

6. Identify What makes it possible for a solution to conduct an electric current?

SECTION 2 Acids and Bases *continued***How Do We Use Acids?**

Acids are important chemicals because they have so many uses. Sulfuric acid is the most widely used chemical in the world. It is used to make many products including paper, paint, and detergents. The sulfuric acid in car batteries conducts the current to help start the car's engine. You can find nitric acid in fertilizers, rubber, and plastic. ✓

READING CHECK

7. Identify Which of the following uses nitric acid: making paper, making paint, or making fertilizers?

Another acid, hydrochloric acid, is used to separate metals from the other materials in their ores. We also put it in swimming pools to keep them free of algae. In addition, hydrochloric acid helps your stomach digest the food you eat.

Food has many kinds of acid in it. For example, orange juice contains citric acid and ascorbic acid (vitamin C). The main ingredient in vinegar is acetic acid. Carbonic acid and phosphoric acid help give soft drinks a sharp taste. ✓

READING CHECK

8. Name What are two foods that contain acid?

What Are Bases?

Bases are found in baking powder, chalk, soap, and even the saliva in your mouth. Bases are the opposite of acids. When a base meets an acid, it *neutralizes* it. That means it cancels out acidity. A **base** is any compound that makes many hydroxide ions (OH⁻) when it is dissolved in water. For example, sodium hydroxide breaks apart to form sodium ions and hydroxide ions when dissolved in water.

Sodium hydroxide → Sodium ion + Hydroxide ion

NaOH → Na⁺ + OH⁻

Bases, such as a solution of sodium hydroxide, will have many more hydroxide ions than hydronium ions.

What Are the Properties of Bases?

Hydroxide ions give bases their properties. These properties make bases very useful substances. Imagine how dirty we would be without soap and other cleaners made from base compounds. ✓

READING CHECK

10. Describe What gives bases their properties?

Critical Thinking

9. Predict What does an antacid tablet do to excess acid in your stomach?

SECTION 2 Acids and Bases *continued***BITTER TASTE AND SLIPPERY FEEL**

The properties of a base solution include a bitter taste and a slippery feel. Have you ever tasted soap? It has a bitter taste. Soap also has the slippery feel of a base.

Never use taste, touch, or smell to identify an unknown chemical. Like acids, many bases are corrosive. If you use a base in an experiment, be very careful. If your fingers feel slippery, you may have gotten the base on your hands. You should quickly rinse your hand with large amounts of water and tell your teacher.

COLOR CHANGE OF INDICATORS

Like acids, bases change the color of an indicator. Bases turn most indicators a different color than acids do. For example, bases change the color of red litmus paper to blue. Bromthymol blue turns a darker blue when you add a base to it.

ELECTRICAL CONDUCTIVITY

Like acids, solutions of bases conduct an electric current. Bases are good conductors because they contain many hydroxide ions (OH^-).



Soaps are made by using sodium hydroxide, which is a base. Soaps remove dirt and oils from skin and feel slippery when you touch them.



Baking soda is a mild base. It is used in toothpastes to neutralize acids, which can produce unpleasant odors.

How Are Bases Used?

Like acids, bases have many uses. Companies use the base sodium hydroxide to make soap and paper. It is also used in oven cleaners and in products that unclog drains. Ammonia is found in many household cleaners and is used to make fertilizers. The antacids people use to treat heartburn contain magnesium hydroxide and aluminum hydroxide. ✓

Critical Thinking

11. Apply Concepts Why do you think it's a bad idea to use taste, touch, or smell to identify an unknown chemical?

TAKE A LOOK

12. Identify What color will baking soda turn litmus paper?

READING CHECK

13. Identify What are two products that contain ammonia?

Section 2 Review

SECTION VOCABULARY

acid any compound that increases the number of hydronium ions when dissolved in water

base any compound that increases the number of hydroxide ions when dissolved in water

indicator a compound that can reversibly change color depending on conditions such as pH

- 1. Explain** What kind of ions do acids have and what kind of ions do bases produce when you dissolve them in water? What happens when you combine an acid and a base?

- 2. Complete** Fill in the table below with the properties of acids and bases. Draw lines between the properties that are the same.

Property	Acids	Bases
Taste		
Color change of litmus paper		
Reaction with metals to produce hydrogen gas		
Electrical conductivity		

- 3. Apply Concepts** Lemon juice is an acid. What ions are present in lemon juice?

- 4. Evaluate Data** A solution conducts electric current. Can you use this property of the solution to determine if it is an acid or a base? Explain.

- 5. Describe** What happens to red litmus paper when it touches a household cleaner that has ammonia in it, and why?

- 6. Identify** What word is used to describe an acid or base that can destroy body tissue, clothing, and many other things?

- 7. Identify** Suppose you are doing an experiment and your fingers feel slippery; what did you probably get on them? What should you do if this happens to you?

CHAPTER 10 Chemical Compounds

SECTION

3

Solutions of Acids and Bases

BEFORE YOU READ

After you read this section, you should be able to answer these questions:

- What does a strong acid or base produce in a solution?
- What does a weak acid or base produce?
- What happens when an acid reacts with a base?
- What do we use to measure pH?



California Science
Standards

8.5.e

What Is a Strong Acid or Base?

Acids and bases can be strong or weak. The strength of an acid or base is not the same as the concentration of an acid or a base. *Concentration* means the amount of acid or base dissolved in water. The strength of an acid or base depends on the number of ions formed when they dissolve in water. ✓

STRONG VERSUS WEAK ACIDS

As an acid dissolves in water, the acid's molecules break apart to form hydrogen ions (H^+). In water, all of the molecules of a *strong acid* break apart forming many ions. Sulfuric acid, nitric acid, and hydrochloric acid are all strong acids. But if you mix a weak acid in water, only a few of its molecules break apart. So, there are only a few hydronium ions in a solution of a weak acid. Acetic acid, citric acid, and carbonic acid are all weak acids. ✓

STRONG VERSUS WEAK BASES

A base is strong if it forms many hydroxide ions (OH^-) when dissolved in water. Sodium hydroxide, calcium hydroxide, and potassium hydroxide are strong bases. When only a few ions are formed, the base is a weak base. Two weak bases are magnesium hydroxide and aluminum hydroxide.



Antacids are weak bases. They help relieve your stomachache by reacting with acid in your stomach.

STUDY TIP

Discuss Read this section silently. With a partner, take turns telling what it is about. Stop to discuss ideas and words that confuse you.

READING CHECK

1. Explain What does the concentration of an acid or base solution tell you?

READING CHECK

2. Explain What is the difference between a strong acid and a weak acid?

SECTION 3 Solutions of Acids and Bases *continued***What Happens When Acids and Bases Mix?**

The base in an antacid reacts with the acid in your stomach. Why does your stomach feel better? Because the reaction between acids and bases makes the excess acid in your stomach neutral. This is called a **neutralization reaction**.

In a neutralization reaction, hydrogen ions (H^+) from the acid combine with hydroxide ions (OH^-) from the base. This reaction forms water, which is neutral. The other ions in the acid and base solution combine to form a compound called a *salt*. ✓

READING CHECK

3. Describe What is formed by a neutralization reaction?

READING CHECK

4. Describe What is pH?

5. Name What kind of solution has a high pH value? What kind has a low pH value?

THE pH SCALE

An indicator such as litmus can show us if a solution contains an acid or a base. We use the pH scale to describe how acidic or basic a solution is.

The **pH** of a solution is a measure of how many hydronium ions it has. A solution that has a pH of 7 is neutral. A neutral solution is not acidic and it is not basic. Pure water has a pH of 7. Basic solutions have a pH greater than 7. Acidic solutions have a pH less than 7. ✓

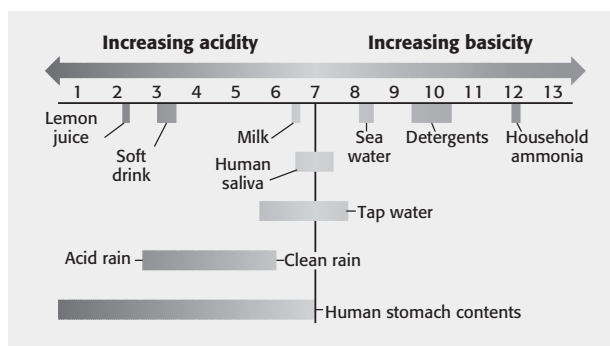
pH Values of Common Materials**USING INDICATORS TO FIND pH**

There are several ways to find out how basic or acidic a solution is. For example, strips of pH paper have several different indicators on them. When you dip them into a solution, the pH paper changes color. You can compare that color to a color scale to find the pH of the solution. People use this kind of indicator to test the pH of water in swimming pools.

Another way to find the pH of a solution is to use an electronic device called a *pH meter*. These meters measure hydronium ion concentration in the solution.

SECTION 3 Solutions of Acids and Bases *continued***pH AND THE ENVIRONMENT**

Living things depend on having a steady pH in their environment. Some plants, such as pine trees, like to grow in acidic soil. The soil has a pH between 4 and 6. Other plants, such as lettuce, need basic soil that has a pH between 8 and 9.

Some plants show different traits with different kinds of soil. For example, the flowers of the hydrangea plant act as a natural indicator. The color of the flowers changes when the plants are grown in soils that have different pH values. Many plants and animals that live in lakes and streams need a neutral pH to survive.

Most rain is slightly acidic and has a pH between 5.5 and 6. Acids form when rainwater reacts with compounds in polluted air, causing the rainwater's pH decreases. In the United States, most acid rain has a pH between 4 and 4.5. However, some acid rain has a pH as low as 3. Water with low pH can harm fish and other animals.

What Are Salts?

When you hear the word *salt*, you probably think of the table salt you use on your food. But the sodium chloride in your saltshaker is only one kind of salt. It is one of a large group of compounds called salts.

When an acid neutralizes a base, a salt and water form. A **salt** is an ionic compound. It forms when a positive ion from a base combines with a negative ion from an acid. As shown below, sodium hydroxide (NaOH) and hydrochloric acid (HCl) make water (H₂O) and sodium chloride (NaCl). ✓

Sodium + Hydrochloric → Water + Sodium
hydroxide acid chloride



Salts have many uses. The sodium chloride in food is also used to melt the snow and ice on roads and sidewalks. We use it to make other compounds, including lye and baking soda. We use the salt sodium chloride to preserve food. Calcium sulfate is used to make wallboard for buildings. ✓

	CALIFORNIA STANDARDS CHECK
8.5.b Students know how to determine whether a solution is acidic, basic, or neutral.	
6. Describe How can the pH of rainwater be determined?	

 **READING CHECK**

7. Describe How is a salt formed?

 **READING CHECK**

8. Name What are two uses of sodium chloride?

Section 3 Review

8.5.e 

SECTION VOCABULARY

neutralization reaction the reaction of an acid and a base to form a neutral solution of water and a salt

pH a value that is used to express the acidity or basicity of a system

salt an ionic compound that forms when a metal atom replaces the hydrogen of an acid

1. Compare What makes an acid a strong acid? What makes a base a weak base?

2. Describe What happens when an acid and a base combine?

3. Complete Fill in the equations below to show the reaction of sodium hydroxide and hydrochloric acid.

Sodium hydroxide + Hydrochloric acid \longrightarrow _____ + Sodium chloride

NaOH + HCl \longrightarrow _____ + _____

4. Identify What are two ways to measure the pH of a solution?

5. Apply Concepts Soap is made from a strong base and oil. Do you think the pH of soap is 4 or 9? Explain why.

6. Explain A lake has a low pH. Is it acidic or basic? Would fish be healthy in this lake?

CHAPTER 11 The Chemistry of Living Things

SECTION

1

Elements in Living Things

BEFORE YOU READ

After you read this section, you should be able to answer these questions:

- What common elements make up living organisms?
- Why is carbon important to living organisms?
- How do carbon atoms combine with other atoms?
- How do scientists use organic compounds to benefit people?



California Science
Standards

8.6.a, 8.6.b

What Elements Make Up Living Organisms?

There are over 90 elements known to exist in the universe. Yet, only a handful of elements make up most of any organism. The most common elements that make up living things are carbon, hydrogen, nitrogen, oxygen, phosphorus, and sulfur. These six elements make up more than 96% of your body weight!

Most Common Elements in the Human Body	
Element	Percentage by weight
Oxygen	65.0
Carbon	18.5
Hydrogen	9.5
Nitrogen	3.3
Phosphorus	1.0
Sulfur	0.3
Other	2.4

Elements combine with one another to form particles called *molecules*. There are many types of molecules in your body. These molecules make up the billions of cells found in your body. Your body has different types of cells. Each kind of cell has its own purpose, and each has some different molecules.

How do so few elements create the many different molecules your body needs? Atoms of these elements combine in different ways. The kinds and locations of the elements in a molecule control how it works.



Outline As you read this section, create an outline. Outlining what you read can help you remember and organize the main ideas.

Math Focus

1. Apply Data Using your weight, in pounds, and the percentage carbon given in the table, calculate the weight of carbon in your body. Show your work.

Critical Thinking

2. Infer Does your body need more than six elements? If so, can you name one or more?

SECTION 1 Elements in Living Things *continued***Why Is Carbon Important to Living Organisms?**

Remember that a *compound* is a group of atoms bonded together. Most of the molecules made in your body are compounds that contain carbon atoms. These are called organic compounds. An **organic compound** is a compound in which carbon is covalently bonded to other carbons and to other atoms. All living things contain organic compounds. Carbon is necessary for life. ✓

There are over a million organic compounds. How can carbon be part of so many different kinds of molecules? Carbon has a property most other elements do not have. Carbon can bond to other carbon atoms in several different ways.

Each carbon atom has four valence electrons. So, a carbon atom can make a total of four bonds. When carbon atoms bond with other carbon atoms, they make what is called a *carbon backbone*. One type of carbon backbone is a long *straight chain*. A chain can form a *ring*. Finally, the carbon atoms can also form a *branched chain* backbone. There are many organic compounds that have at least one of these three basic shapes. ✓

READING CHECK

3. Define What is an organic compound?

READING CHECK

4. Identify How many bonds can a carbon atom form with other atoms?

TAKE A LOOK

5. Identify What are the three kinds of carbon backbones?

READING CHECK

6. Describe How many electrons are shared in a single bond?

Three Kinds of Carbon Backbones

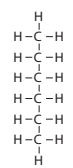
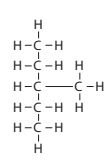
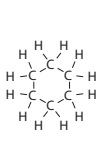
		
Straight chain	Branched chain	Ring
Carbon atoms are connected one after another.	The chain of carbon atoms branches when a carbon atom bonds to more than two other carbon atoms.	The chain of carbon atoms forms a ring.

How Does Carbon Combine with Other Atoms?**SINGLE BONDS**

When a carbon atom shares only one pair of electrons with another atom, the bond is called a *single bond*. In the figure above, all bonds are single bonds. Gasoline contains many molecules with single covalent bonds. ✓

Gasoline is made from petroleum, from deep in Earth's crust. The organic compounds in petroleum are from the remains of organisms that lived long ago.

SECTION 1 Elements in Living Things *continued***DOUBLE BONDS**

A carbon atom can also form a *double bond* by sharing two pairs of electrons. A double bond is stronger than a single bond. ✓

Imagine that you are a carbon atom. Your two arms and two legs are bonds that can be made when you join to other people. If you use each hand or foot to join to someone else, you can connect to four people. This represents four single bonds.

However, if you hold onto another person's arm with both hands, then you have a stronger hold on that person. This represents a double bond. You can still bond to two other people with your feet.

TRIPLE BONDS

A carbon atom can form a *triple bond* with another atom by sharing three pairs of electrons. A triple bond is stronger than a double bond.

The figure below shows that the names of three-carbon compounds tell the kinds of bonds they have.

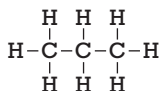
Three Types of Bonds Between Carbon Atoms**Single Bond**

The **propane** in a camping stove contains only single bonds.

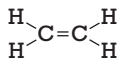
Double Bond

Fruits make **ethene**, which is a compound that helps ripen the fruit.

Triple Bond

Ethyne is better known as *acetylene*. It is burned in miners' lamps and in welding torches.

How Do Scientists Use Organic Compounds to Benefit People?

When organic compounds were first discovered, scientists thought they could be made only inside living things. However, scientists now use technology to make many organic compounds. These include useful products such as vitamins and medicines. Scientists are also trying to make organic compounds to help the environment. For example, they are trying to make fuels that don't pollute as much as gasoline.

READING CHECK

7. Describe How many electrons are shared in a double bond?

**CALIFORNIA STANDARDS CHECK**

8.6.c Students know that carbon, because of its ability to combine in many ways with itself and other elements, has a central role in the chemistry of living organisms.

8. Identify What are the three types of bonds that a carbon atom can form with another atom?

TAKE A LOOK

9. Analyze Models What is the largest number of atoms a carbon atom can bond to with all single bonds?

10. Analyze Models What if one of the bonds is a double bond?

11. Analyze Models What if one of the bonds is a triple bond?

Section 1 Review

8.6.a, 8.6.b



SECTION VOCABULARY

organic compound a covalently bonded compound that contains carbon	
---	--

1. Identify What are the six most common elements found in organic compounds?

2. Analyze What properties of carbon make it important for living organisms?

3. Apply You are a chemist who has found an unknown organic compound. Your data show the compound is made of carbon and hydrogen atoms. There are four carbon atoms. All the bonds are single covalent bonds. Based on what you know about the types of carbon backbones, draw the three structures possible for this compound.

4. Infer Petroleum products such as gasoline are made of compounds containing carbon. How can you use this clue to hypothesize where petroleum originally comes from?

5. Evaluate Name an example of an organic compound made by scientists. How is it used to benefit people?

6. Explain How can an organic compound exist without single bonds between the carbons?

CHAPTER 11 The Chemistry of Living Things

SECTION 2 **Compounds of Living Things**

BEFORE YOU READ

After you read this section, you should be able to answer these questions:

- Why is water important for living things?
- How does salt help your body cells function?
- What are four complex organic compounds needed by living things?



California Science Standards

8.3.c, 8.6.c

Why Is Water Important for Living Things?

Water is one of the simplest compounds that all living things need. In fact, about 70% of your body weight is due to water. Water is found everywhere in your body. It is inside your cells. It surrounds your tissues and joints, and it is inside your blood vessels. Although you may not realize it, the water you drink helps your body do many important things.

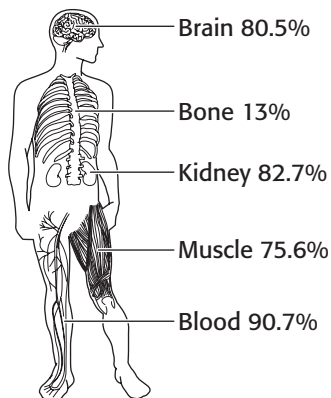

The percentage of water is not the same in different parts of your body.

STUDY TIP

Memorize When you come across new vocabulary words, create flashcards to help you remember their meanings. Write each word on one side of an index card. Then, write its definition (and other important facts) on the other side.

Math Focus

1. Analyze Data If a human body has about 10 pounds of blood, how much does the water in the blood weigh? Show your work.

Water helps you control your body temperature. It stores heat and insulates your body in cold surroundings. On a hot day, water cools your body. It does this by evaporating from your skin in the form of sweat.

Water make the joints in your body move more easily. Water surrounds your bones and joints and delicate organs such as the eyes and brain. Water cushions these parts from shock.

Water has other functions in your body. It transports many nutrients and other substances around your body. As your body produces waste, water also helps dilute the waste and remove it. In addition, water is needed by your cells to make the molecules you use for energy. ✓

READING CHECK

2. Identify Name five ways that your body needs water in order to function properly.

SECTION 2 Compounds of Living Things *continued*



Animals have salt in their bodies. Therefore, they need to have a certain amount of salt in their diets.

CALIFORNIA STANDARDS CHECK

8.6.c Students know that living organisms have many different kinds of molecules, including small ones, such as water and salt, and very large ones, such as carbohydrates, fats, proteins, and DNA.

3. Explain When athletes exercise very hard, it is important for them to replace salts lost from their bodies. How can low amounts of salts affect electrical signals in your body?

Why Do Living Things Need Salt?

Why is the deer licking salt in the figure above? The deer must replace the salt that is lost from its body. If you've ever tasted sweat or tears, you know that your body also contains salt. There are different types of salt. The salt you usually eat is sodium chloride. There are other salts that are made of elements such as potassium and calcium.

All of these salts are present in your body and have vital functions. Salts help transport materials in and out of the cells. Cells use a difference in electrical charge inside and outside the cell membrane to move materials in and out. Cells use the charges carried by salt ions to do this.

Salts are also used to conduct electrical signals throughout your body. This is especially important for nerve cells, muscle cells, and heart cells.

What Organic Compounds Do Living Things Need?

Living things require simple compounds such as water and salts. They also need large complex compounds. Can you think of some examples? You may have read about carbohydrates and proteins on food labels. Cells need carbohydrates, lipids, proteins, and nucleic acids in order to function. ✓



Eating well-balanced meals is important for your body. Carbohydrates, proteins, and lipids come from different foods.

READING CHECK

4. Identify What four complex compounds are needed by the human body?

SECTION 2 Compounds of Living Things *continued***CARBOHYDRATES**

Compounds made of one or more molecules of simple sugar are called **carbohydrates**. Small sugar molecules can join together to form complex carbohydrates. The figure below shows a glucose (simple sugar) molecule and a sucrose (table sugar) molecule. You can see that the sucrose is made of two simple sugars joined together.

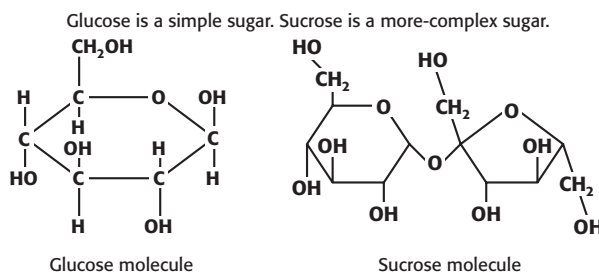

A complex carbohydrate can be made of thousands of simple sugars arranged in a long chain of repeating units. This chain is called a *polymer*. ✓

Cells use carbohydrates as an energy source. For example, your body breaks down carbohydrates and stores some of the energy in muscle cells in the form of molecules called *glycogen*. Carbohydrates also have other uses in cells. Cellulose, a type of carbohydrate, forms cell walls that give plants their rigid structure.

LIPIDS

Lipids are organic compounds that do not dissolve in water. Lipids are fat-soluble; that is, they dissolve in fats. Examples of lipids include fats, oils, and waxes. Like carbohydrates, they are required by living things. Though too much fat in your diet is unhealthy, some fat is important to help you maintain good health.

Lipids are large molecules made mostly of carbon and hydrogen atoms. Saturated fats are lipids with only single bonds between the carbon atoms. Unsaturated fats are lipids that contain double bonds.

Lipids have many roles in living things. One role is to store energy. When carbohydrates or glycogen are not available, cells use energy stored in your body fat. Fat layers under your skin and around your organs also protect and insulate your body.

The vitamins A, D, E, and K are necessary for good health. They are fat-soluble, so they need fat to work properly. They are also stored in your body fat.

TAKE A LOOK

5. Identify How many simple sugar molecules make up one molecule of sucrose?

 **READING CHECK**

6. Describe What is a polymer?

Critical Thinking

7. Infer Vitamins A, D, E, and K can reach dangerous levels in a person's body if he or she takes too many vitamin supplements. What do you think is the reason?

SECTION 2 Compounds of Living Things *continued***PROTEINS**

Proteins are organic compounds made of building blocks called *amino acids*. Most proteins are large molecules made of long-chain polymers of amino acids. Each type of protein in a cell has its own special structure. This structure depends on the way the amino acid chains fold together. Think of folding a shirt while doing laundry. There are different ways to fold it. With proteins, the way one is folded affects its function in the body.

There are only 20 different types of amino acids, the protein building blocks. However, the possible combinations of amino acids are almost limitless. For example, a simple prokaryotic bacteria such as *Escherichia coli* has over 1,000 different proteins. ✓

READING CHECK

8. Identify What are proteins made of?



Human hair

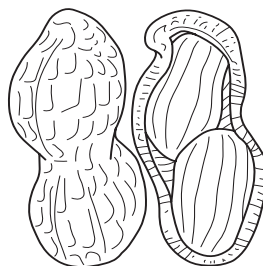

Peanuts



Red blood cells

Proteins play a variety of important roles in living organisms.

Proteins have a wide range of important functions in living things. The figure above shows some examples of different proteins. Keratin protein in hair is strong and lightweight. Nuts are foods dense in proteins that store energy.

Your body has other unique proteins that help keep you healthy. One important protein in red blood cells is *hemoglobin*. Hemoglobin carries oxygen to all the cells in your body. It also carries away carbon dioxide. ✓

Many hormones are proteins. For example, *insulin* is a protein hormone that helps control the level of sugar in your blood. This is important for maintaining a steady flow of energy.

Antibodies in your body are also made of proteins. Antibodies attach to and destroy bacteria.

READING CHECK

9. Identify What is the protein that carries oxygen to your body cells?

SECTION 2 Compounds of Living Things *continued***NUCLEIC ACIDS**

The largest organic compounds made by living things are nucleic acids. **Nucleic acids** are made up of sugars, phosphates, and nucleotides. *Nucleotides* are molecules made of carbon, oxygen, hydrogen, nitrogen, and phosphorus. Four different nucleotides are found in the nucleic acid known as DNA. They are adenine, thymine, guanine, and cytosine. ✓

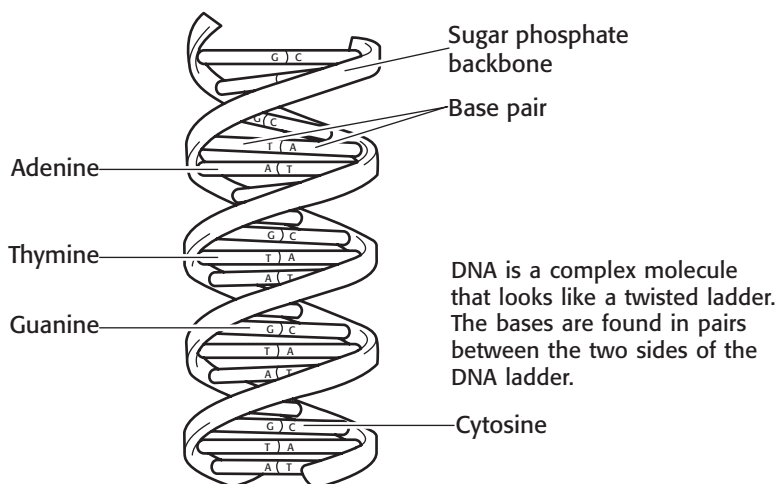

Nucleic acids store genetic information. They are sometimes called “the blueprints of life.” This is because they carry all the information needed for a cell to make all of its proteins. If the protein code in a nucleic acid is changed, the proteins it affects will not function normally.

Think of the differences in eye color between you and your friends. They are due to differences in the nucleotide patterns for proteins that make up the eye. The differences in nucleotide sequences result in different traits and different species.

DNA AND RNA

There are two different types of nucleic acids: DNA and RNA. A model of DNA is shown above. DNA is the genetic material found in the nuclei of your cells. DNA exists in long-chain polymers. If you stretched out the DNA in a human cell, it would stretch about six feet!

When a cell needs to make a certain protein, it copies a small part of the DNA onto another type of nucleic acid called RNA. The RNA is moved out of the nucleus and into the cytoplasm. The RNA directs the organization of amino acids into a specific protein. ✓

READING CHECK

10. Identify What are nucleic acids made of?

TAKE A LOOK

11. Identify Which base is always paired with thymine?

Say It

Predict Report to the class on what might happen if there were a change in the nucleic acids needed to make hemoglobin.

READING CHECK

12. Describe What instructions does RNA contain?

Section 2 Review

8.3.c, 8.6.c 

SECTION VOCABULARY

carbohydrate a class of energy-giving nutrients that includes sugars, starches, and fiber; contains carbon, hydrogen, and oxygen

lipid a type of biochemical that does not dissolve in water; fats and steroids are lipids

Wordwise The root *lip* means “fat.”

nucleic acid a molecule made up of subunits called nucleotides

protein a molecule that is made up of amino acids and that is needed to build and repair body structures and to regulate processes in the body

1. **Infer** How does water act as your body’s “shock cushion” ?

2. **Fill In** Complete the Spider Map of the compounds discussed in this section that are vital for living things. Below each compound, tell if it is a small molecule or a large molecule.

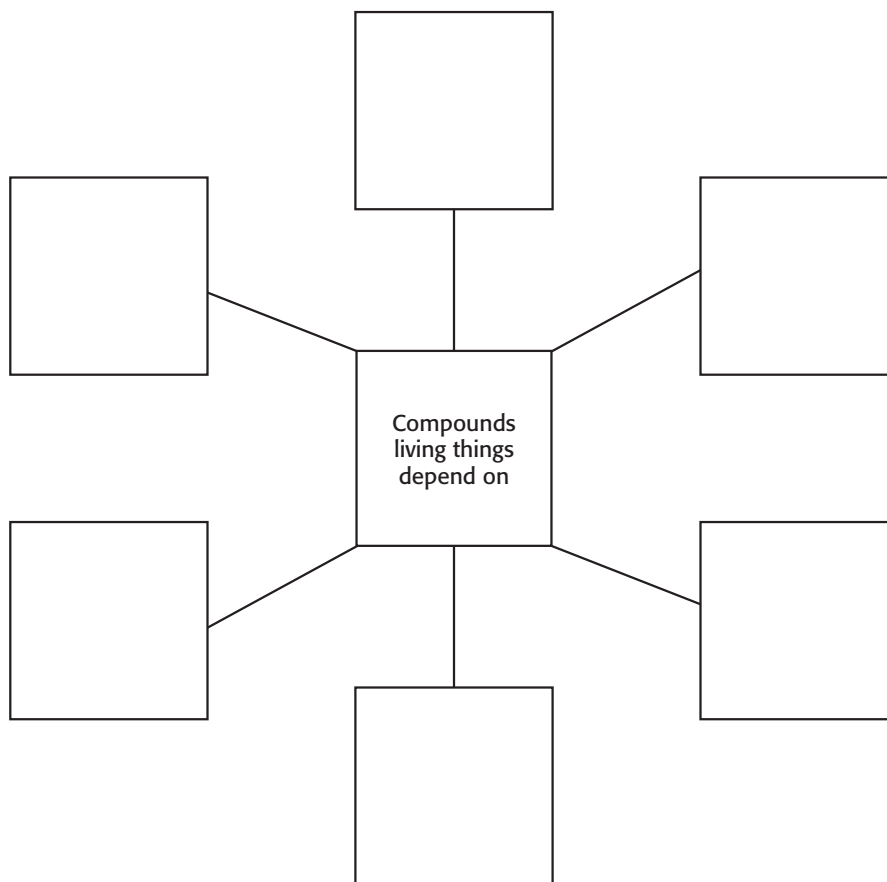

3. **Identify** Long-chain proteins and long-chain carbohydrates are examples of the type of molecule called a _____.

4. **Classify** What can both carbohydrates and lipids provide for the body?

Measuring Motion

BEFORE YOU READ

After you read this section, you should be able to answer these questions:

- What is motion?
- How can motion be described?
- How are speed and velocity different?
- How are velocity and acceleration different?



California Science Standards

8.1.a, 8.1.b, 8.1.c, 8.1.d, 8.1.e, 8.1.f

What Is Motion?

Look around the room for a moment. What objects are in motion? Are students writing with pencils in their notebooks? Is the teacher writing on the board? Motion is all around you, even when you can't see it. Blood is circulating throughout your body. Earth orbits around the sun. Air particles shift in the wind.

Often, when you watch an object move, you are watching it in relation to another object that seems to stay in one place. The object that seems to stay in one place is a *reference point*. When an object changes position over time in relation to a reference point, the object is in **motion**. ✓

You can use *standard reference directions* (such as north, south, east, and west, or right and left) to describe the motion of an object. You can also use features on Earth's surface, such as buildings or trees, as reference points. The figure below shows how a mountain can be used as a reference point to show the motion of a hot-air balloon.

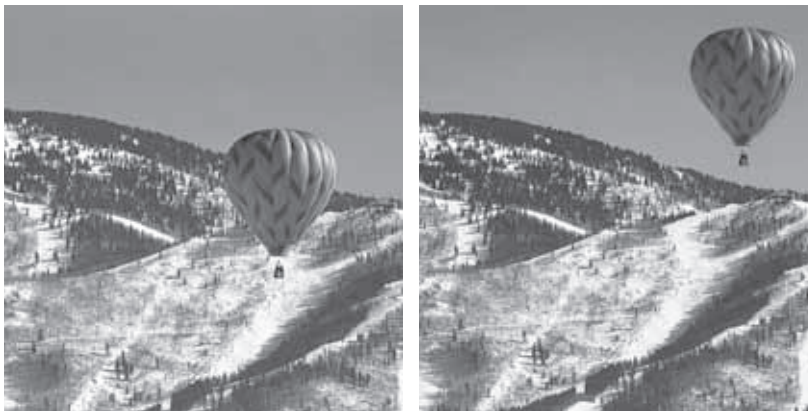

The hot-air balloon changed position relative to a reference point.

STUDY TIP

Describe Graphs When you see a graph that looks confusing, look carefully at the title and all the labels. In the margin, write a sentence or two explaining what the graph shows.

**READING CHECK**

1. Describe What must be true about an object that serves as a reference point?

TAKE A LOOK

2. Identify What is the fixed reference point in the photos?

SECTION 1 Measuring Motion *continued*

How Can Motion Be Shown?

In the figure below, a sign-up sheet is being passed around a classroom. You can follow its path. The paper begins its journey at the reference point, the origin.

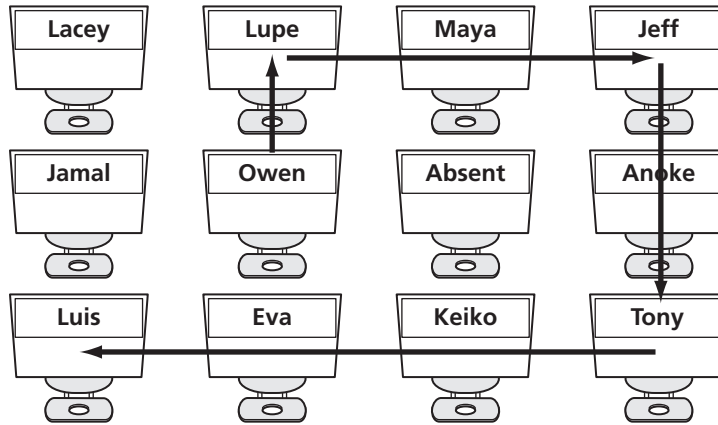

The path taken by a field trip sign-up sheet

TAKE A LOOK

3. Identify What is the origin, or reference point, of the paper?

The figure below shows a graph of the position of the sign-up sheet as it is passed around the class. The paper moves in this order:

1. One positive unit on the *y*-axis
2. Two positive units on the *x*-axis
3. Two negative units on the *y*-axis
4. Three negative units on the *x*-axis

The graph provides a method of using standard reference directions to show motion.

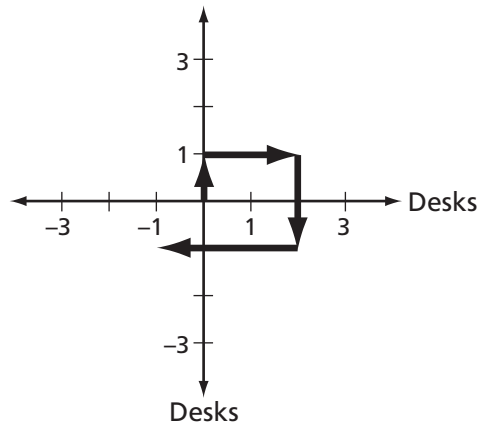

The position of the sign-up sheet as it moves through the classroom.

Math Focus

4. Graph Describe the shortest path that the paper could take to return to Owen's desk. The paper cannot move diagonally.

SECTION 1 Measuring Motion *continued*

What Is Average Speed?

Speed is the rate at which an object moves. Speed is rarely constant. Suppose you were running a race. You might begin slowly, then increase your speed, and finally sprint at your top speed across the finish line. You would not run the race at the same speed for the entire time.

Average speed is found by dividing the total distance traveled by the total time taken. You can use the following equation to find average speed:

$$\text{average speed} = \frac{\text{total distance}}{\text{total time}}$$

Suppose that it takes you 2 s to walk 4 m down a hallway. You can use the equation above to find your average speed:

$$\text{average speed} = \frac{4 \text{ m}}{2 \text{ s}} = 2 \text{ m/s}$$

Your speed is 2 m/s. Units for speed include meters per second (m/s), kilometers per hour (km/h), feet per second (ft/s), and miles per hour (mi/h).

How Can You Show Speed on a Graph?

You can show speed on a graph by showing how the position of an object changes over time. The *x*-axis shows the time it takes to move from place to place. The *y*-axis shows distance from the reference point.

Suppose you watched a dog walk beside a fence. The graph above shows the total distance the dog walked in 10 s. The line is not straight because the dog did not walk the same distance in each second. The dog walked slowly for 2 s and then quickly for 1 s. From 3 s to 5 s, the dog did not move.

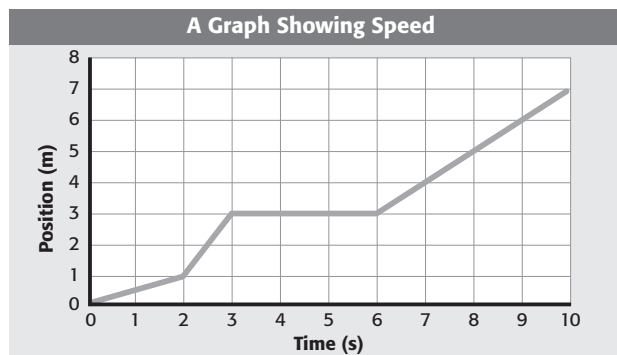

A graph of position versus time also shows the dog's speed during his walk. The more slanted the line, the faster the dog walked.

The average speed of the dog is

$$\text{average speed} = \frac{\text{total distance walked}}{\text{total time}} = \frac{7 \text{ m}}{10 \text{ s}} = 0.7 \text{ m/s}$$

CALIFORNIA STANDARDS CHECK

8.1.d Students know that average speed is the total distance traveled divided by the total time elapsed and that the speed of an object along the path traveled can vary.

5. Explain The average flight speed of a bald eagle is about 50 km/h. A scientist has measured an eagle flying 80 km/h. How is this possible?

Math Focus

6. Calculate Suppose you walked 10 m down a hallway in 2.5 s. What is your average speed? Show your work.

Math Focus

7. Apply Concepts Suppose the dog walked at a constant speed the whole way. On the graph, draw a line showing that the dog walked at a constant speed.

SECTION 1 Measuring Motion *continued*

CALIFORNIA STANDARDS CHECK

8.1.d Students know the velocity of an object must be described by specifying both direction and the speed of the object.

Word Help: **specify** to state or tell clearly

8. Analyze Someone tells you that the velocity of a car is 55 mi/h. Is this correct? Explain your answer.

What Is Velocity?

Suppose that two birds leave the same tree at the same time. They both fly at 10 km/h for 5 min, 12 km/h for 8 min, and 5 km/h for 10 min. However, they don't end up in the same place. Why not?

Understanding the problem above will help you to understand velocity. The birds did not end up in the same place because they flew in different directions. Their speeds were the same, but because they flew in different directions, their velocities were different. **Velocity** is the speed of an object and its direction.

The velocity of an object is constant as long as both the speed and the direction the object is moving are also constant. If a bus driving at 15 m/s south speeds up to 20 m/s south, its velocity changes. If the bus keeps moving at the same speed but changes direction from south to east, its velocity also changes. If the bus brakes to a stop, the velocity of the bus changes again.

You can see in the table below that velocity is a combination of both the speed of an object and the direction.

Speed	Direction	Velocity
15 m/s	south	15 m/s south
20 m/s	south	20 m/s south
20 m/s	east	20 m/s east
0 m/s	east	0 m/s east



Share Experiences Have you ever experienced a change in velocity on an amusement park ride? In pairs, share an experience. Explain how the velocity changed—was it a change in speed, direction, or both?

Velocity changes when the speed changes, when the direction changes, or when both speed and direction change. The table below describes various situations in which the velocity changes.

Situation	What changes
Raindrop falling faster and faster	
Runner going around a turn on a track	direction
Car taking an exit off a highway	speed and direction
Train arriving at a station	speed
Baseball being caught by a catcher	speed
Baseball being hit by a batter	
	speed and direction

TAKE A LOOK

9. Identify Fill in the missing parts of the table to show how velocity changes.

SECTION 1 Measuring Motion *continued*

What Is Acceleration?

Acceleration is how quickly velocity changes. An object accelerates if its speed changes, if its direction changes, or if both its speed and direction change.

The units for acceleration are the units for velocity divided by a unit for time. The resulting unit is often meters per second per second (m/s/s or m/s²).

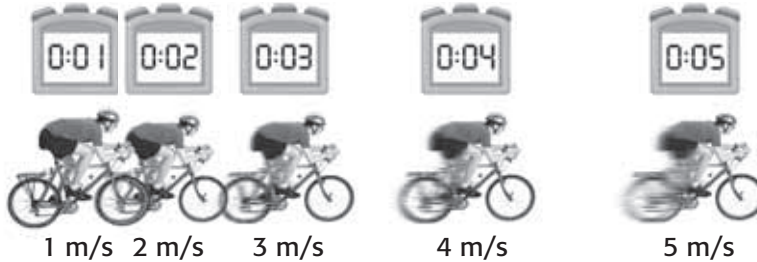

This cyclist moves faster and faster as he peddles his bike south.

Looking at the figure above, you can see that the speed increases by 1 m/s during each second. This means that the cyclist is accelerating at 1 m/s².

An increase in speed is referred to as *positive acceleration*. A decrease in speed is referred to as *negative acceleration* or *deceleration*. ✓

Acceleration can be shown on a graph of speed versus time. Suppose you are operating a car by remote control. You push the lever on the remote to move the car forward. The graph below shows the car's acceleration as the car moves east. For the first 5 s, the car increases in speed. The car's acceleration is positive because the speed increases as time passes.

For the next 2 s, the speed of the car is constant. This means the car is no longer accelerating. Then the speed of the car begins to decrease. The car's acceleration is then negative because the speed decreases over time.

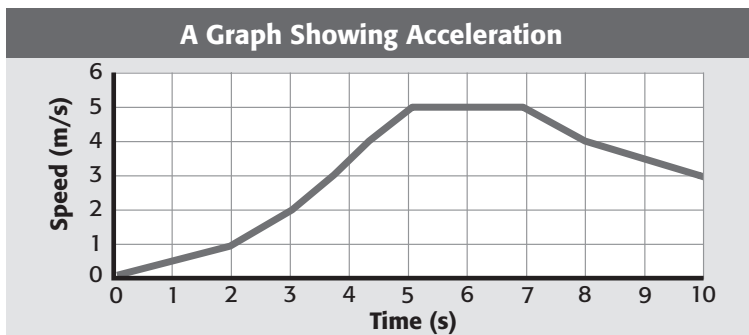

The graph of speed versus time also shows that the acceleration of the car was positive and negative. Between 5 s and 7 s, it had no acceleration.

TAKE A LOOK

10. Identify Is the cyclist accelerating? How do you know?

READING CHECK

11. Explain What happens to an object when it has negative acceleration?

Math Focus

12. Interpret Graphs Is the slope positive or negative when the car's speed increases? Is the slope positive or negative when the car's speed decreases?

Section 1 Review

8.1.a, 8.1.b, 8.1.c, 8.1.d, 8.1.e, 8.1.f

SECTION VOCABULARY

acceleration the rate at which the velocity changes over time; an object accelerates if its speed, direction, or both change

average speed the total distance traveled divided by the total time taken

motion an object's change in position relative to a reference point

velocity the speed of an object in a particular direction

1. Identify What is the difference between speed and velocity?

2. Complete a Graphic Organizer Fill in the graphic organizer for a car that starts from one stop sign and approaches the next stop sign. Use the following terms: constant velocity, positive acceleration, deceleration, and at rest.

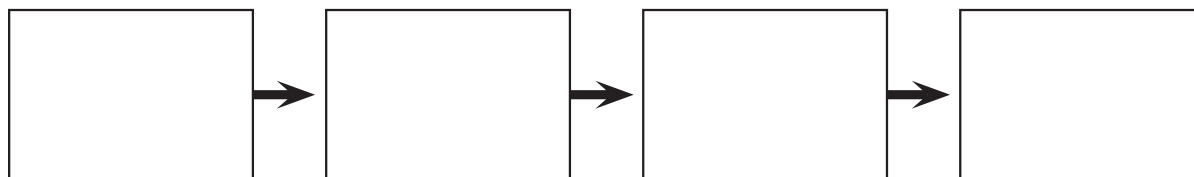

3. Interpret a Graph Describe the motion of the skateboard using the graph below. Write what the skateboard does from time = 0 s to time = 40 s.

Position Verses Time for a Skateboard

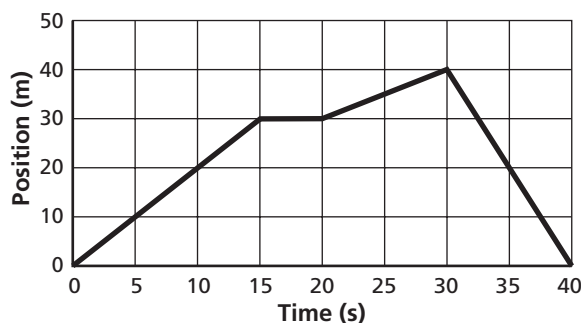

4. Calculate The graph above shows that the skateboard went a total distance of 80 m. What was the average speed of the skateboard? Show your work.

What Is a Force?

BEFORE YOU READ

After you read this section, you should be able to answer these questions:

- What is a force?
- How can a force be measured?
- How do balanced and unbalanced forces affect objects?



California Science Standards

8.2.a, 8.2.b, 8.2.c, 8.2.d, 8.2.e

What Is a Force?

You probably hear people talk about force often. You may hear someone say, “That storm had a lot of force” or “Mrs. Larsen is the force behind the school dance.” But what exactly is a force in science?

In science, a **force** is a push or a pull. All forces have two properties: direction and magnitude, or size. A **newton** (N) is the unit that describes the magnitude of a force.

Forces act on the objects around us in ways that we can see. If you kick a ball, the ball receives a push from you. If you drag your backpack across the floor, the backpack is pulled by you.

Forces also act on objects around us in ways that we cannot see. For example, in the figure below, a student is sitting on a chair. What are the forces acting on the chair?

The student is pushing down on the chair, but the chair does not move. Why? The floor is balancing the force by pushing up on the chair. When the forces on an object are balanced, the object does not move.

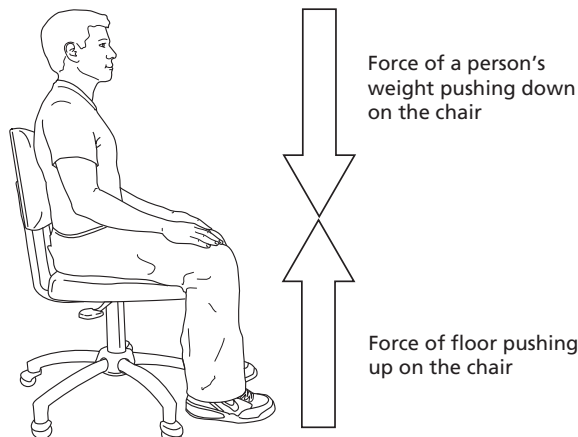

A person sitting on a chair

STUDY TIP

Brainstorm As you read, think about different objects, inside and outside. What forces are affecting them? How do the forces affect them?

CALIFORNIA STANDARDS CHECK

8.1.a Students know a force has both direction and magnitude.

1. List What two properties do all forces have?

TAKE A LOOK

2. Explain When an object is not moving, what do you know about the forces acting on it?

SECTION 2 What Is a Force? *continued*

How Do Forces Combine?

As you saw in the example of the student sitting in the chair, often more than one force acts on an object. The result is the combined effect of the forces. This is called the **net force** on an object.

FORCES ACTING IN THE SAME DIRECTION



When forces act in the same direction, you add the forces to determine the net force. The net force will be in the same direction as the individual forces.

Suppose your music teacher asks you and a friend to move a piano, as shown in the figure above. You push the piano from one end and your friend pulls the piano from the other end. You and your friend are applying forces in the same direction. Adding the two forces gives you the size of the net force. The direction of the net force is the same as the direction of the forces.

$$125 \text{ N} + 120 \text{ N} = 245 \text{ N}$$

net force = 245 N to the right

FORCES ACTING IN OPPOSITE DIRECTIONS



When two forces act in opposite directions, you subtract the smaller force from the larger force to determine the net force.

Suppose two dogs are playing tug of war, as shown above. Each dog is exerting a force on the rope. In this case, the forces are in opposite directions. Which dog is winning the tug of war?

You can find the size of the net force by subtracting the smaller force from the bigger force. The direction of the net force is the same as that of the larger force:

$$120 \text{ N} - 80 \text{ N} = 40 \text{ N}$$

net force = 40 N to the right

TAKE A LOOK

3. Identify On the figure, draw an arrow showing the direction and magnitude of the net force on the piano. Make sure the length of the arrow represents the size of the force.

CALIFORNIA STANDARDS CHECK

8.2.b Students know when an object is subject to two or more forces at once, the result is the cumulative effect of all the forces.

4. Analyze In the example about moving the piano, what are the two forces that combine to form the net force?

Critical Thinking

5. Predict What would happen if both dogs pulled the rope with a force of 85 N?

SECTION 2 What Is a Force? *continued*

What Happens to an Object When Forces Are Balanced?

Objects that are not moving are said to be *static*. Balanced forces are acting on a static object. Because they are balanced, there is no change in the motion of the object. This means that the net force is 0 N. Remember, even when an object is static, forces are acting on it.

In many cases, the forces acting on static objects are tension or compression. *Tension* is a force that acts on an object when it is pulled or stretched. *Compression* is a force that is exerted when matter is pushed or squeezed.

A rope bridge is a good example of an object that has both tension and compression acting on it. The figure below shows the compression and tension acting on a rope bridge.

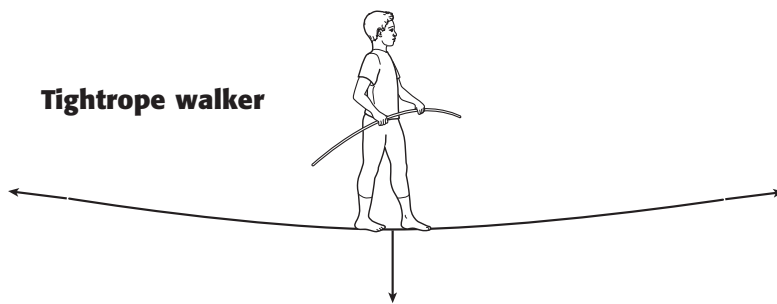

Static objects will not start moving when balanced forces are acting on them. The figure below shows other examples of balanced forces.



◀ The kittens rest comfortably without moving. The downward force of their weight is balanced by the force of compression in the cushion pushing upward.



◀ The dog cannot walk into the surf because the force that the dog is exerting is balanced by the tension in the leash held by the dog's owner.



▶ The bird feeder does not fall down because the weight of the bird and the bird feeder is balanced by the force of tension in the wire.

TAKE A LOOK

6. Identify Label each force arrow as "tension" or "compression."

	CALIFORNIA STANDARDS CHECK
<p>8.2.c Students know when the forces on an object are balanced, the motion of the object does not change.</p>	
<p>7. Explain Look at the picture. Why doesn't the bird feeder fall to the ground?</p>	
<hr/>	
<hr/>	
<hr/>	

SECTION 2 What Is a Force? *continued*

CALIFORNIA STANDARDS CHECK

8.2.e Students know that when the forces on an object are unbalanced, the object will change its velocity (that is, it will speed up, slow down, or change direction).

8. Identify Why does the velocity of an arrow change as it travels toward the target?

What Happens to an Object When Forces Are Not Balanced?

If the forces acting on an object are not balanced, the forces are unbalanced. *Unbalanced forces* cause a change in the velocity of an object, which may be a change in speed, direction, or both. If unbalanced forces act on an object, the net force is not 0 N.

MOVING OBJECTS

Think about a soccer game for a moment. A soccer ball is kicked from player to player. When the soccer ball is kicked from one player to the next, the kick is an unbalanced force that sends the ball in a new direction with a new speed.

NONMOVING OBJECTS

Unbalanced forces cause nonmoving objects to start moving. A soccer ball that sits stationary in the middle of a soccer field is acted on by balanced forces. If you were to kick it, the ball would be acted on by unbalanced forces and would start moving.

READING CHECK

9. Describe How can you make an unmoving object start moving?

DIRECTION OF MOVEMENT

You have learned that forces have direction. You have also learned that unbalanced forces can cause a change in the direction of motion of an object.

Objects do not always move in the direction of an unbalanced force. When the space shuttle lands, it moves forward even though it has a parachute. The parachute exerts an unbalanced force pulling it backward. This force acts to slow the shuttle, not to change its direction.

TAKE A LOOK

10. Apply Concepts What do you know about the magnitude of the forces acting on the space shuttle during landing?



Section 2 Review

8.2.a, 8.2.b, 8.2.c, 8.2.d, 8.2.e 

SECTION VOCABULARY

force a push or a pull exerted on an object in order to change the motion of the object; force has size and direction

net force the combination of all the forces acting on an object

newton the SI unit for force (symbol, N)

1. Explain If there are many forces acting on an object, how can the net force be 0?

2. Complete Label the empty boxes with the type of force, tension or compression, shown by the direction of the arrows.

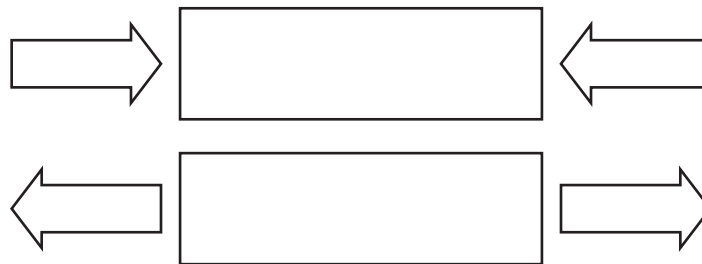

3. Calculate Determine the net force on each of the objects shown below. Don't forget to give the direction of the force.

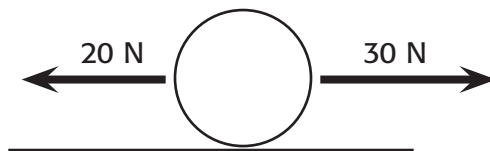

net force = _____

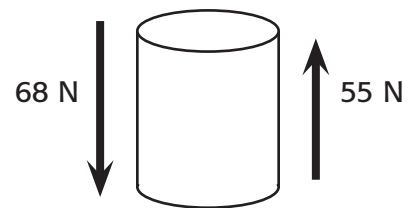

net force = _____

4. Explain Describe how the objects shown above will be affected by the forces acting on them.

5. Give Examples Give an example of an object that is under compression. In what way is the object under compression?

Friction: A Force That Opposes Motion



California Science Standards

8.2.a, 8.2.c, 8.2.d, 8.2.e

BEFORE YOU READ

After you read this section, you should be able to answer these questions:

- What is friction?
- What effect does friction have on motion?
- What types of friction are there?
- How can friction be increased or reduced?

STUDY TIP

Imagine As you read, think about the ways that friction affects your life. Make a list of things that might happen, or not happen, if friction did not exist.

READING CHECK

1. **Explain** What is friction?

TAKE A LOOK

2. **Explain** Why can't you see the hills and valleys without a close-up view of the objects?

What Causes Friction?

You are playing soccer. You kick the ball far from you. Rather than run after the ball, you walk after it because you know that the ball will slow down and eventually stop. This means that the velocity of the ball will decrease to 0. You also know that an unbalanced force is needed to change the velocity of objects. So, what force is stopping the ball?

Friction is the force that opposes the motion between two surfaces that touch. Friction causes the ball to slow down and eventually stop. ✓

The surface of any object is rough. Even an object that feels smooth is covered with tiny hills and valleys. When two surfaces touch, the hills and valleys of one surface stick to the hills and valleys of the other surface. This contact between surfaces causes friction.

If a force pushes two surfaces together even harder, the hills and valleys come closer together. This increases the friction between the surfaces.

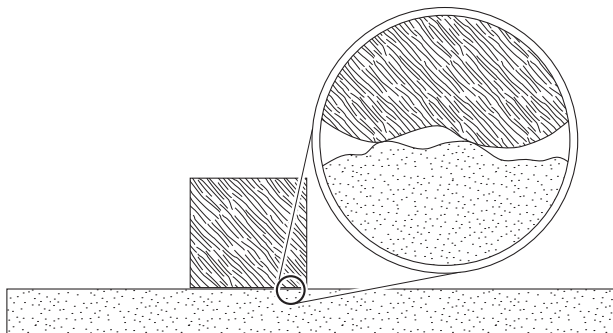

When the hills and valleys of one surface stick to the hills and valleys of another surface, friction is created.

SECTION 3 Friction: A Force That Opposes Motion *continued*

What Effect Does the Material Have on Friction?

Consider what might happen if a ball is rolled over a carpeted floor and another ball is rolled over a wood floor. Which surface affects a ball more? The amount of friction on the carpet is greater than the amount of friction on the wood floor, so the ball on the carpet stops first.

The smoothness of the surfaces of the objects affects how much friction exists. Friction is usually greater between materials that have rough surfaces than materials that have smooth surfaces.

What Types of Friction Exist?

There are two types of friction: kinetic friction and static friction. *Kinetic friction* occurs when force is applied to an object and the object moves. When a cat slides along a countertop, the friction between the cat and the countertop is kinetic friction. The word kinetic means “moving.”

The amount of kinetic friction between moving surfaces depends partly on how the surfaces move. In some cases, the surfaces slide past each other. In others, one surface rolls over another. There is usually less friction between surfaces that roll than between surfaces that slide.

Static friction occurs when force applied to an object does not cause the object to move. When you try to push a piece of furniture that will not move, the friction observed is static friction.

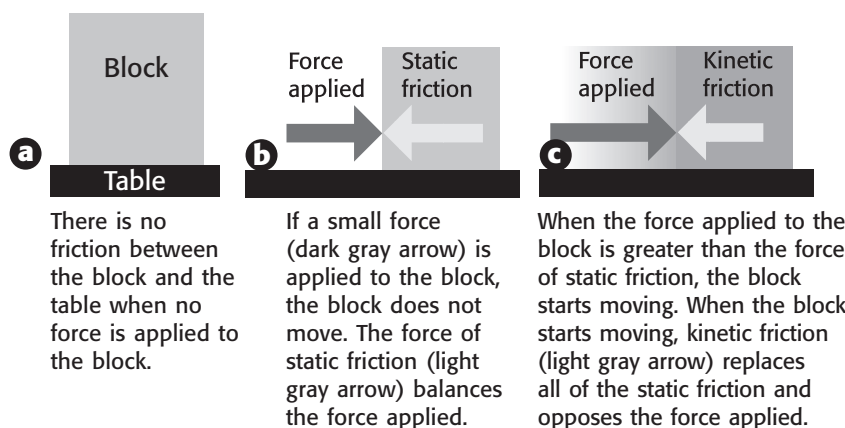

 **CALIFORNIA STANDARDS CHECK**

8.2.e Students know that when the forces on an object are unbalanced, the object will change its velocity (that is, it will speed up, slow down, or change direction).

3. Describe How does friction cause the velocity of an object to change?

TAKE A LOOK

4. Describe When does static friction become kinetic friction?

SECTION 3 Friction: A Force That Opposes Motion *continued*

Critical Thinking

5. Infer How does a lubricant reduce the amount of friction?

TAKE A LOOK

6. Describe Why is it important to put oil on a bicycle chain?

Critical Thinking

7. Apply Concepts How does applying force make it easier to clean?

How Can Friction Be Decreased?

To reduce the amount of friction, you can apply a lubricant between two surfaces. A *lubricant* is a substance that reduces the friction between surfaces. Motor oil, wax, and grease are examples of lubricants.

You can also reduce friction by rolling, rather than sliding, an object. A refrigerator on rollers is much easier to move than one that just slides.

Another way of reducing friction is to smooth the surfaces that rub against each other. Skiers have their skis sanded down to make them smoother. This makes it easier for the skis to slide over the snow.



If you work on a bicycle, you may get dirty from the chain oil. This lubricant reduces friction between sections of the chain.

How Can Friction Be Increased?

To increase the amount of friction, you can make the surfaces rougher. On icy roads, sand can be added to provide more friction so cars do not slide.

You can also increase friction by increasing the force between the two objects. Have you ever scrubbed a dirty pan in the kitchen sink? You may have found that increasing the amount of force you apply to the pan with the scrubber allows you to increase the amount of friction. This makes it easier to clean the pan.



Section 3 Review

8.2.a, 8.2.c, 8.2.d, 8.2.e 

SECTION VOCABULARY

friction a force that opposes the motion between two surfaces that are in contact

1. Describe What effect does friction have when you are trying to move an object?

2. Compare Explain the difference between static friction and kinetic friction. Give an example of each.

3. Compare The figure on the left shows two surfaces up close. On the right, draw a sketch. Show what the surfaces of two objects that have less friction between them might look like.

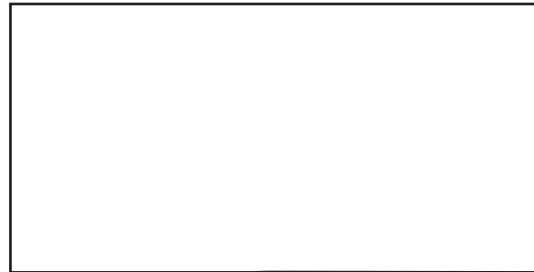
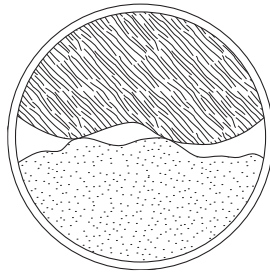

4. Analyze Name three common lubricants and describe how they work.

5. Analyze In what direction does friction always act?

6. Identify A car is driving on a flat road. When the driver hits the brakes, the car slows down and stops. What would happen if there were no friction? Explain your answer.

SECTION 1 Gravity: A Force of Attraction



8.2.a, 8.2.c, 8.2.d, 8.2.e, 8.2.g

BEFORE YOU READ

After you read this section, you should be able to answer these questions:

- What is gravity?
- What is the difference between weight and mass?
- How does gravity affect static objects?

STUDY TIP

Discuss Ideas Take turns reading this section out loud with a partner. Stop to discuss ideas that seem confusing.

READING CHECK

1. **Describe** What is gravity?

Critical Thinking

2. **Infer** Why can't you see two soccer balls attracting each other?

How Does Gravity Affect Matter?

Have you ever seen a video of astronauts on the moon? There is a photograph of a moon walk below. The astronauts bounced around the moon like beach balls, even though the space suits weighed 180 pounds on Earth. Why is it easier for a person in a space suit to move on the moon than on Earth? The reason is that the moon has less gravity than Earth. **Gravity** is a force of attraction, or a pull, between objects that is due to their masses. ✓

All matter has mass. Gravity is a result of mass. Therefore, all matter has gravity. This means that all objects attract all other objects in the universe! The force of gravity pulls objects toward each other. For example, gravity between the objects in the solar system holds the solar system together.

Small objects also have gravity. You have gravity. This book has gravity. Why don't you notice the book pulling on you or you pulling on the book? The reason is that the book's mass and your mass are both small. The force of gravity caused by small mass is not large enough to move either you or the book.



Because the moon has less gravity than Earth does, walking on the moon's surface was a very bouncy experience for the Apollo astronauts.

SECTION 1 Gravity: A Force of Attraction *continued*

How Are an Apple and the Moon Similar?

According to a story, Sir Isaac Newton, while sitting under an apple tree, watched an apple fall. This gave him a bright idea. Like many others, Newton had wondered what kept the planets in the sky. Newton realized that an unbalanced force on the apple made it fall.

He then thought about the moon’s orbit. He realized that an unbalanced force on the moon kept it moving around Earth. Newton said that these forces are both gravity.

Newton’s ideas are known as the *law of universal gravitation*. This law says two things about gravitational force:

1. It depends on the masses of the objects.
2. It depends on the distance between the objects.

The word “universal” is used because the law applies to all objects. Newton said that all objects in the universe attract each other. This attraction is gravitational force. ✓

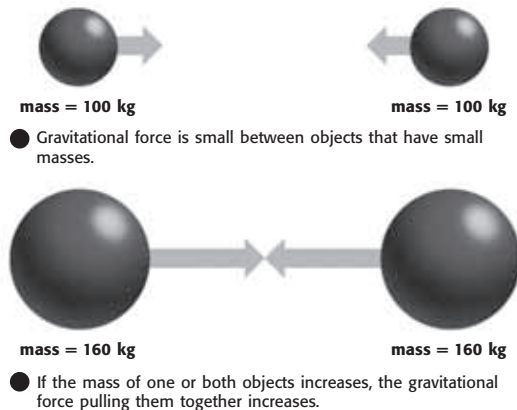

The arrows indicate the gravitational force between two objects. The length of the arrows indicates the magnitude of the force.

How Is Gravitational Force Related to Mass?

The gravitational force between objects depends on the product of the masses of the objects. This part of the law of universal gravitation explains why an astronaut on the moon can jump around so easily.

The moon has less mass than Earth does. This gives the moon a weaker pull on objects than the Earth has. The astronauts on the moon are not pulled down as much as they would be on Earth. Therefore, they can jump higher and more easily on the moon.

CALIFORNIA STANDARDS CHECK

8.2.g Students know the role of gravity in forming and maintaining the shapes of planets, stars, and the solar system.

Word Help: maintain to keep the same

3. Compare Why does the moon revolve around Earth?

READING CHECK

4. Identify What two things determine gravitational force?

TAKE A LOOK

5. Compare Is the gravitational force greater between objects with small masses or objects with large masses?

SECTION 1 Gravity: A Force of Attraction *continued*

How Is Gravitational Force Related to Distance?

If you jump up and down on a pogo stick, you return to Earth every time you jump rather than catapult toward the sun. You have learned that the force of gravity pulls you down to Earth. However, you have also learned that the gravitational force is related to the mass of the objects. The sun is more than 300,000 times bigger than Earth. Why don't you keep moving toward the sun when you jump on a pogo stick?

The answer is that the gravitational force also depends on the distance between the objects. As the distance between two objects gets larger, the force of gravity gets much smaller. In the reverse, as the distance between objects gets smaller, the force of gravity gets much bigger. ✓

TAKE A LOOK

6. Describe Use the diagram to describe the affect of distance on gravitational force.

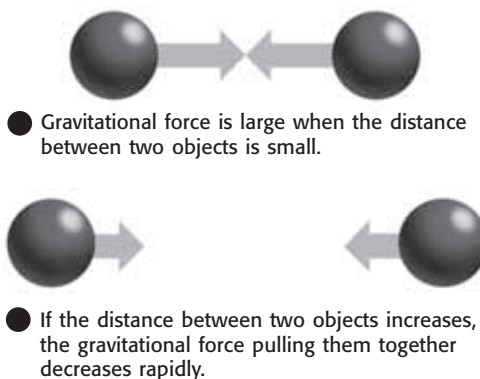

The length of the arrows indicates the magnitude of the gravitational force between two objects.

READING CHECK

7. List What two characteristics affect gravity?

Although the sun has tremendous mass, it is also very far away. This means that it has very little gravitational force on your body or on small objects around you, including your books or the pogo stick. The sun does have a large gravitational force on the planets because the mass of the planets is much bigger (especially compared to you!).

SECTION 1 Gravity: A Force of Attraction *continued*

What Is the Difference Between Mass and Weight?

You have learned that gravity is a force of attraction between objects. **Weight** is a measure of the gravitational force on an object. Weight is expressed using the newton (N) as a unit of force.

Mass is a measure of the amount of matter in an object. This seems similar to weight, but it is not the same. Mass is usually expressed in kilograms (kg) or grams (g). An object's mass does not change when gravitational forces change, but its weight does. ✓

In the figure below, you can see the difference between mass and weight. Compare the astronaut's mass and weight on Earth with her mass and weight on the moon.

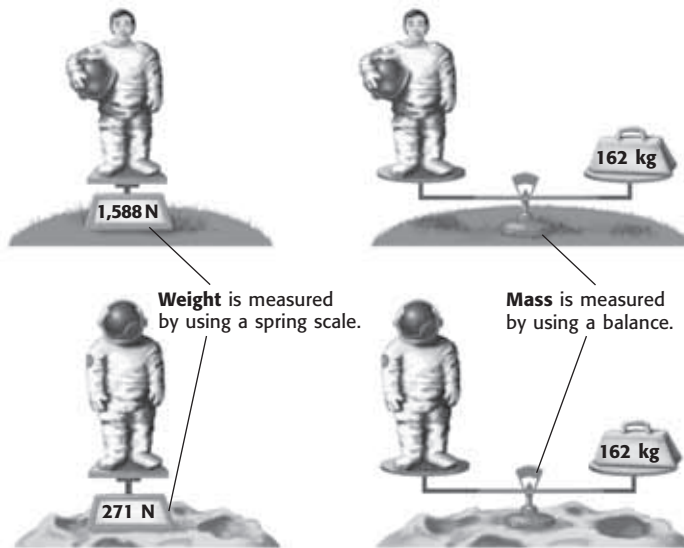

Gravity can cause objects to move because it is a type of force. Gravity also acts on objects that are not moving, or *static*. Earth's gravity pulls static objects downward. Static objects do not move downward, though, because they are balanced by an upward force. Suppose a framed picture hangs from a nail. Gravity pulls the picture downward, but tension pulls the picture upward toward the nail. The forces are balanced, so the framed picture does not move.

READING CHECK

8. Contrast How is mass different from weight?

TAKE A LOOK

9. Identify What is the weight of the astronaut on Earth? What is the weight of the astronaut on the moon?

Critical Thinking

10. Contrast What forces act on a framed picture on a shelf?

Section 1 Review

8.2.a, 8.2.c, 8.2.d, 8.2.e, 8.2.g



SECTION VOCABULARY

gravity a force of attraction between objects that is due to their masses

mass a measure of the amount of matter in an object

weight a measure of the gravitational force exerted on an object; its value can change with the location of the object in the universe

1. Identify What is gravity? What determines the gravitational force between objects?

2. Describe A spacecraft is moving toward Mars. Its rocket engines are turned off. As the spacecraft nears Mars, what will happen to the pull of the planet's gravity?

3. Summarize Describe how weight and mass of an astronaut are different on Earth and on the moon.

4. Apply Concepts An astronaut visits Planet X. Planet X has the same radius as Earth but has twice the mass of Earth. Fill in the table below to show the astronaut's mass and weight on Planet X. (Hint: Newton's law of universal gravitation says that when the mass of one object doubles, the force due to gravity also doubles.)

	Earth	Planet X
Mass of the astronaut	80 kg	
Weight of the astronaut	784 N	

5. Select Each of the spheres shown below is made of iron. Circle the pair of spheres that would have the greatest gravitational force between them. Below the spheres, explain the reason for your choice.

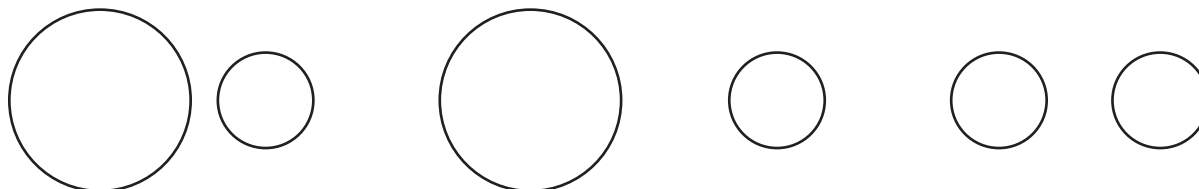

Gravity and Motion

BEFORE YOU READ

After you read this section, you should be able to answer these questions:

- How is acceleration related to gravity?
- When does acceleration stop?
- When does free fall occur?



California Science Standards

8.2.a, 8.2.b, 8.2.e, 8.2.f, 8.2.g

How Do Objects Fall?

Suppose you dropped a baseball and a marble at the same time. Which would land on the ground first?

If you thought that the baseball would land first, you were thinking along the same lines as Aristotle, a Greek philosopher, who lived around 400 BCE. He thought that the rate at which an object falls depends on its mass. Because the baseball has the larger mass, he would have predicted that it would land on the ground first.

If you thought that the baseball and marble would land at the same time, your thinking is like that of Galileo Galilei, an Italian scientist in the 16th century. Galileo thought that the mass of an object does not affect the time the object takes to fall to the ground. According to one story, Galileo proved his argument by dropping two cannon balls of different masses from a tower.

This stop-action photo shows that a table-tennis ball and a golf ball fall at the same rate even though they have different masses.

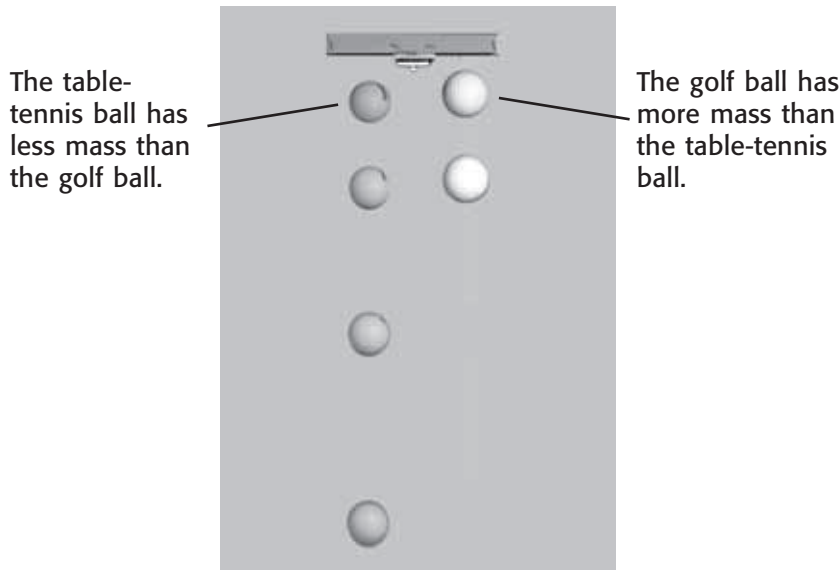

STUDY TIP

Compare In your Science Notebook, make a Comparison Table that compares the motion of falling bodies without air resistance, with air resistance, and with a starting forward velocity.

READING CHECK

1. Contrast How does Aristotle's idea about how two objects would fall differ from Galileo's?

TAKE A LOOK

2. Observe In the figure, the last two positions of the golf ball are not shown. Draw two circles to show where the golf ball would be found.

SECTION 2 Gravity and Motion *continued*

How Does Acceleration Affect Falling Objects?

Acceleration is how quickly velocity changes. An object accelerates when the forces on it are unbalanced. As you know, gravity exerts a downward, unbalanced force on falling objects. So, objects accelerate as they fall.

A table-tennis ball and a golf ball fall to the ground at the same rate. This is because acceleration due to gravity is the same for all objects. How can this be?

Acceleration depends on both force and mass. A heavier object is pulled by a greater gravitational force than a lighter object. But a heavier object is also harder to accelerate because of its larger mass. The extra mass of the heavy object exactly makes up for its larger gravitational force. ✓

Falling objects accelerate toward Earth at a rate of 9.8 meters per second per second. This is written as 9.8 m/s^2 . For every second that an object falls, its downward velocity increases by 9.8 m/s.

READING CHECK

3. Examine Why do objects of the same size and shape fall to the ground at the same rate?

TAKE A LOOK

4. Compare How much faster does the ball fall each second? How did you get this answer?

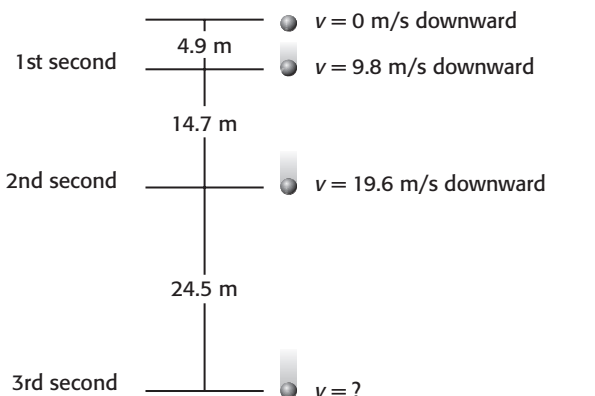

A falling object accelerates at a constant rate. The object falls faster and farther each second than it did the second before.

You can calculate the final velocity (v_{final}) of an object falling from rest by using the following equation:

$$v_{\text{final}} = g \times t$$

In this equation, g is the acceleration due to gravity, and t is the time the object falls. Let's use the equation to find the final speed of the ball after 4 s. ✓

$$v_{\text{final}} = g \times t$$

$$v_{\text{final}} = 9.8 \text{ m/s}^2 \times 4 \text{ s} = 39.2 \text{ m/s downward}$$

Would 39.2 m/s downward be the velocity after the 4th second in the figure above? The answer is yes because $29.4 + 9.8 = 39.2$.

READING CHECK

5. Identify What does each variable stand for in the equation?

SECTION 2 Gravity and Motion *continued*

How Does Air Resistance Affect Falling Objects?

Suppose you were to drop two sheets of paper—one crumpled into a tight ball and the other kept flat. What would happen? You would find that the flat piece of paper would fall more slowly than the crumpled piece of paper.

Air resistance is the force that acts against the motion of objects through air. How much air resistance acts on an object depends on the size, shape, and speed of the object. The figure below shows how shape changes the way a sheet of paper will fall.

How Air Resistance Affects Velocity

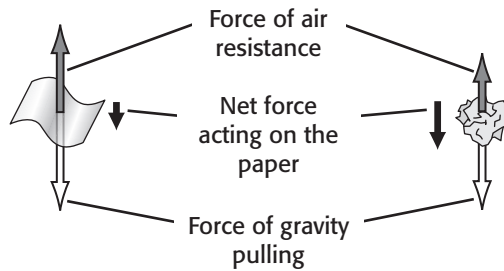

The upward force of air resistance continues to increase as an object falls. It gets larger until it is equal to the downward force of gravity. At this point, the net force is 0 N, and the object stops accelerating. The object then falls at a constant velocity called the **terminal velocity**. If an object falls for a long enough time, it will reach a terminal velocity. ✓

Hailstones have a terminal velocity between 5 m/s and 40 m/s, depending on their mass. If there were no air resistance, hailstones would hit the ground at velocities near 350 m/s! Imagine the danger that hailstones would pose for people, houses, and cars.

TAKE A LOOK

6. Identify What two forces combine to determine the net force on a falling object?

7. Explain Why does the crumpled paper fall faster than the flat paper?

READING CHECK

8. Describe What is terminal velocity?

SECTION 2 Gravity and Motion *continued*

What Is Free Fall?

Often you will hear about a sky diver who is in “free fall.” This isn’t the correct use of this term. An object is in **free fall** if the only force acting on the object is gravity. A sky diver has a large air resistance as she falls.

Because air resistance is a force, free fall can occur only where there is no air. There is no air, or any other matter, in a *vacuum*. Vacuum chambers are containers from which most of the air has been removed. ✓

The figure below shows two objects falling in a vacuum chamber. Because there is almost no air resistance, the two objects are in free fall.

Air resistance usually causes a feather to fall more slowly than an apple falls. But in a vacuum, a feather and an apple fall with the same acceleration because both are in free fall.

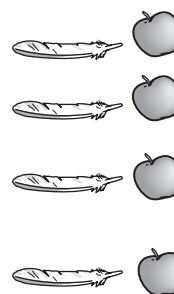

READING CHECK

9. Describe What is a vacuum?

TAKE A LOOK

10. Predict Which will hit the bottom of the chamber first? Explain your answer.

What Is Projectile Motion?

Have you ever seen a bullfrog jump? Have you seen a swimmer dive into the water? Have you ever sprayed water from a hose? These are all examples of projectile motion. **Projectile motion** is the curved path an object follows when it is thrown or propelled near the surface of Earth. Horizontal and vertical movements combine to form a curved path. ✓

Although the horizontal and vertical movements combine, the two motions are separate from each other in a very important way. The horizontal motion does not influence the vertical motion.

READING CHECK

11. Describe What are the two components or parts of projectile motion?

SECTION 2 Gravity and Motion *continued*

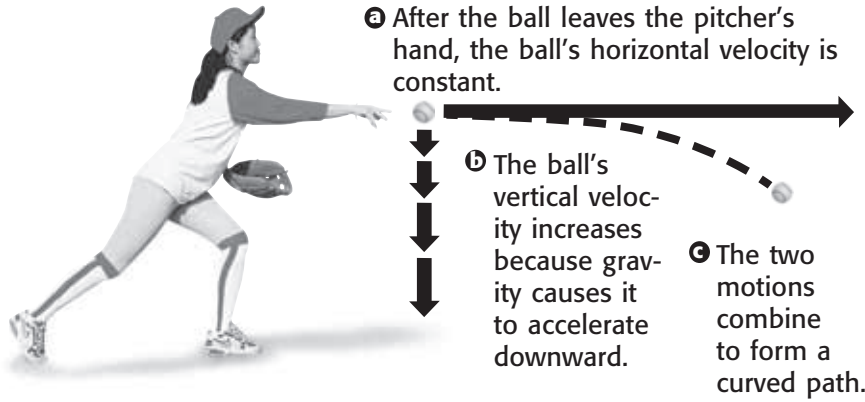

Suppose you throw a ball to a friend. The horizontal and vertical motions of the ball form the curved path as shown in the figure above.

HORIZONTAL MOVEMENT

Your hand gives a force to the ball that makes the ball move forward. This is the horizontal movement, which is parallel to the ground. After the ball leaves your hand, no horizontal forces are acting on the ball (if you ignore air resistance). The horizontal velocity of the ball stays constant after the ball leaves your hand. ✓

VERTICAL MOVEMENT

Gravity pulls everything on Earth down toward the center of Earth. A ball in your hand doesn't fall because your hand is holding the ball. After you throw the ball, gravity pulls the ball down. Gravity gives the ball vertical movement, which is movement perpendicular to the ground. Gravity pulls the ball down at an acceleration of 9.8 m/s^2 (ignoring air resistance).

Objects in projectile motion accelerate down. You always have to aim above a target if you want to hit it with a thrown object. If you want to shoot an arrow at a round bull's-eye, you have to aim above the bull's-eye. If you aim at a bull's-eye on a target, the arrow will hit below it.

Arrow Shot at a Bull's-Eye



Critical Thinking

12. Apply the Concept What gives an arrow shot horizontally from a bow its vertical movement?

READING CHECK

13. Identify After a thrown ball leaves your hand, what happens to its horizontal velocity?

Critical Thinking

14. Apply Concepts Draw the path that the arrow took to the target.

SECTION 2 Gravity and Motion *continued*

How Does Gravity Affect Orbiting?

An object is orbiting when it is moving around another object in space. A spacecraft orbiting Earth is moving forward, but it is also in free fall toward Earth. In the figure below, you can see how these two movements come together to form an orbit. ✓

READING CHECK

15. Identify What two motions form an orbit?

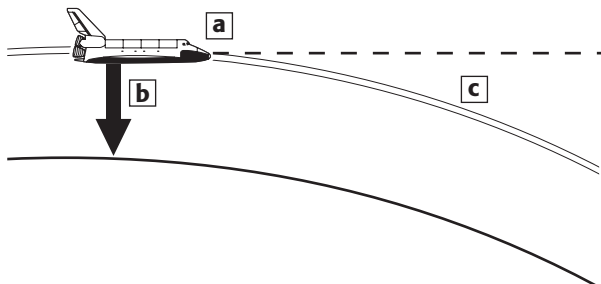

- a. The space shuttle moves forward at a constant speed. If there were no gravity, the space shuttle would continue to move in a straight line.
- b. The space shuttle is in free fall because gravity pulls it toward Earth. The space shuttle would move straight down if it were not traveling forward.
- c. The path of the space shuttle follows the curve of Earth's surface. This path is known as an orbit.

Critical Thinking

16. Predict What would happen to the space shuttle if it lost its forward motion?

Notice how the forward movement and the free fall movement of the space shuttle combine. Together they form the movement called *orbiting*. This is similar to how horizontal and vertical motions combine to form projectile motion. Of course, many other objects are in orbit in the universe. The moon orbits Earth. The planets orbit the sun. What forces act on objects in orbit?

Centripetal force is the unbalanced force that makes things move in a circular path. The word centripetal means “toward the center.” Gravity provides the centripetal force that keeps things in orbit. ✓

READING CHECK

17. Explain What does a centripetal force do?

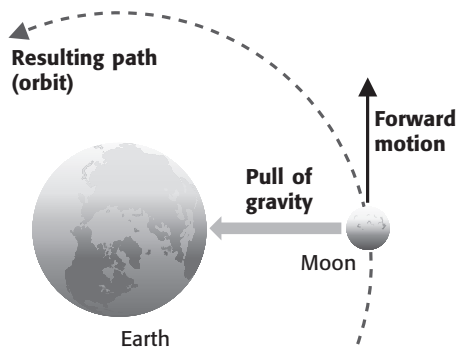

Gravity changes the straight-line path of the moon into a curved orbit. **What kind of force provided by gravity keeps the moon in orbit around Earth?**

SECTION 2 Gravity and Motion *continued*

How Does Gravity Affect Objects in the Solar System?

Gravity maintains the shape of the solar system. Gravity between the sun and the planets keeps the planets in orbit around the sun. Gravity provides a centripetal force on the planets. Gravity also keeps the moons in orbit around their planets. The rings of Saturn, which are made of tiny pieces of ice and dust, are kept in place because of gravity.

Gravity makes the paths that planets follow nearly circular. This kind of shape is called an *ellipse*. An ellipse is sometimes called an oval. Examples of everyday objects that are shaped like ellipses include watermelons and footballs.

In the figure below, you can see that the paths of the planets look circular. But they are really ellipses. This type of path is called *elliptical*.

The Solar System

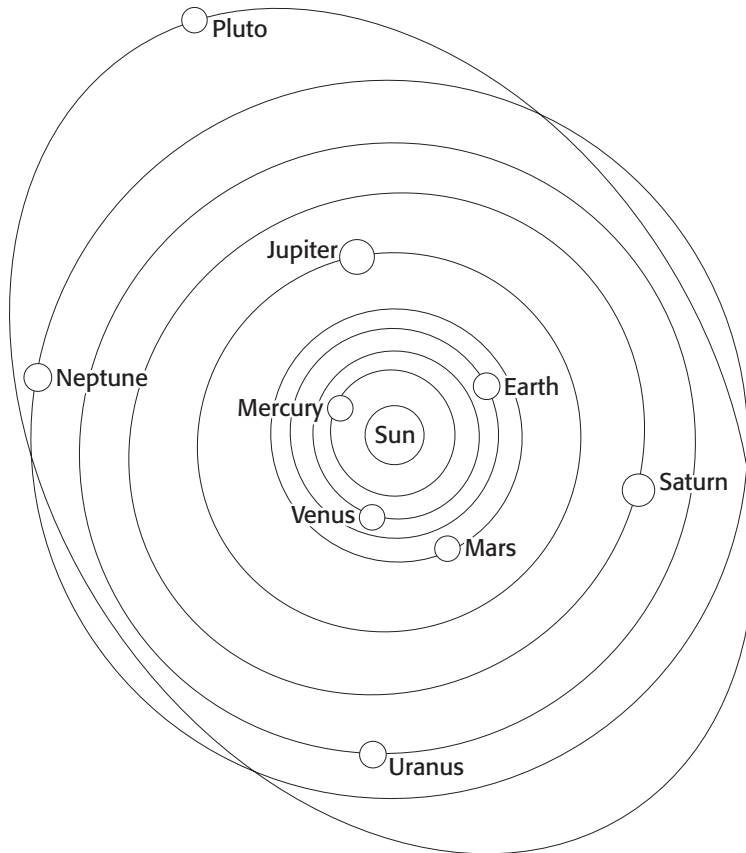

	CALIFORNIA STANDARDS CHECK
<p>8.2.g Students know the role of gravity in forming and <u>maintaining</u> the shapes of planets, stars, and the solar system.</p>	
<p>Word Help: <u>maintain</u> to keep the same</p>	
<p>18. Compare How does gravity maintain the orbits in the solar system?</p> <p>_____</p> <p>_____</p>	

TAKE A LOOK

19. Identify Which planet has the most elliptical orbit?

Section 2 Review

8.2.a, 8.2.b, 8.2.3, 8.2.f, 8.2.g 

SECTION VOCABULARY

free fall the motion of a body when only gravity is acting on the body

projectile motion the curved path an object follows when it is thrown or propelled near the surface of Earth

terminal velocity the constant velocity of a falling object when the force of air resistance is equal to the magnitude and opposite in direction to the force of gravity

1. Justify A brick has a greater mass than a sponge has. Why is the acceleration due to gravity the same for both objects?

2. Complete Identify the forces that cause motion.

Motion	Forces
Object in free fall	<hr/> <hr/>
Object falling at terminal velocity	<hr/> <hr/>
Arrow traveling at a target	<hr/> <hr/>
Satellite orbiting Earth	<hr/> <hr/>

3. Analyze How does air resistance affect the acceleration of falling objects?

4. Explain What force is needed to keep objects in circular motion? What supplies this force to keep planets in the solar system in orbit?

Newton's Laws of Motion

BEFORE YOU READ

After you read this section, you should be able to answer these questions:

- What is net force?
- What happens to objects that have no net force acting on them?
- How are mass, force, and acceleration related?
- How are force pairs related by Newton's third law of motion?



California Science Standards

8.2.c, 8.2.e, 8.2.f

What Is a Net Force?

A force is a push or a pull. It is something that causes an object to change speed or direction. There are forces acting on all objects every second of the day. They are acting in all directions.

At first, this might not make sense. After all, there are many objects that are not moving. Are there forces acting on an apple sitting on a desk? The answer is yes. Gravity is pulling the apple down. The desk is pushing the apple up.

In the figure below, the arrows represent the size and direction of the forces on the apple.

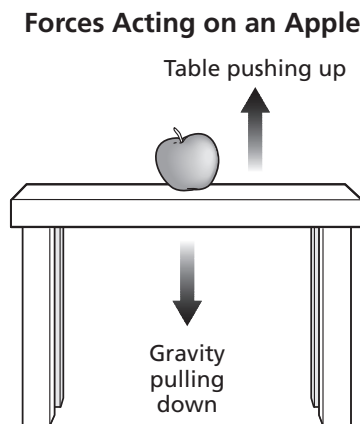

So why doesn't the apple move? The apple is staying where it is because all the forces balance out. There are no unbalanced forces. There is no net force on the apple. *Net force* is the total force acting on an object. If the net force on an object is zero, the object will not change speed or direction. ✓



Summarize in Pairs Read this section silently to yourself. Talk about what you read with a partner. Together, try to figure out any ideas that you didn't understand.

TAKE A LOOK

1. Compare What is the size of the force pulling down compared to the size of the force pushing up?



READING CHECK

2. Explain What will not happen to an object if the net force acting on it is zero?

SECTION 3 Newton's Laws of Motion *continued*

What Is Newton's First Law of Motion?

Newton's first law of motion describes objects that have no unbalanced forces, or no net force, acting on them. It has two parts:

1. An object at rest will remain at rest.
2. An object moving at a constant velocity will continue to move at a constant velocity.

PART 1: OBJECTS AT REST

An object that is not moving is said to be *at rest*. A golf ball on a tee is an example of an object at rest. An object at rest will not move unless an unbalanced force is applied to it. The golf ball will keep sitting on the tee until it is struck by a golf club.

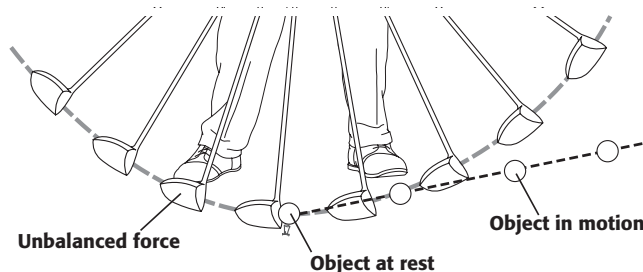

A golf ball will remain at rest on a tee until it is acted on by the unbalanced force of a moving club.

PART 2: OBJECTS IN MOTION

The second part of Newton's first law can be hard to picture. On Earth, all objects that are moving eventually slow down and stop, even if we are no longer touching them. This is because there is always a net force acting on these objects. We will talk about this force later.

However, in outer space, Newton's first law can easily be seen. During the Apollo missions to the moon, the spacecraft turned off its engine when it was in space. It then drifted thousands of miles to the moon. It could keep moving forward without turning on its engines because there was no unbalanced force to slow it down.

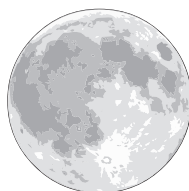

Spacecraft travel to the moon at constant velocity.

TAKE A LOOK

3. Predict What would happen to the distances between the moving ball images if the unbalanced force were greater?

Critical Thinking

4. Apply Concepts What must the spacecraft do to land softly on the moon?

SECTION 3 Newton's Laws of Motion *continued*

How Does Friction Affect Newton's First Law?

On Earth, friction makes observing Newton's first law difficult. If there were no friction, a ball would roll forever until something got in its way. Instead, it stops quickly because of friction.

Friction is a force that is produced whenever two surfaces touch each other. Friction always works against motion. ✓

Friction makes a rolling ball slow down and stop. It also makes a car slow down when its driver lets up on the gas pedal.

What Is Inertia?

Newton's first law is often called the law of inertia.

Inertia is the ability of an object to oppose any change in motion. In order to change an object's motion, a force has to overcome the object's inertia. So, in order to move an object that is not moving, you have to apply a force to it. Likewise, in order to change the motion of an object that is moving, you have to apply a force to it. The greater the object's inertia, the harder it is to change its motion.

How Are Mass and Inertia Related?

An object that has a small mass has less inertia than an object with a large mass. Imagine a golf ball and a bowling ball. Which one is easier to move?

The golf ball has much less mass than the bowling ball. The golf ball also has much less inertia. This means that a golf ball will be much easier to move than a bowling ball. ✓

The figure below further shows how mass affects inertia.

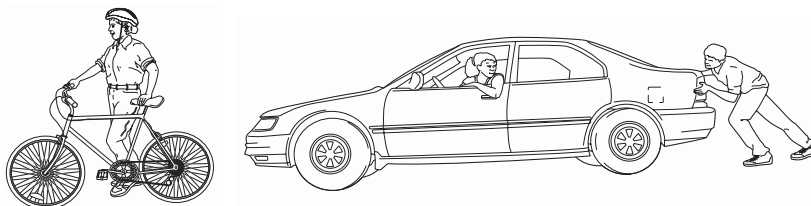

Inertia makes it harder to accelerate a car than to accelerate a bicycle. Inertia also makes it easier to stop a moving bicycle than a car moving at the same speed.

✓ **READING CHECK**

5. Describe How does friction affect the forward motion of an object?

	CALIFORNIA STANDARDS CHECK
<p>8.2.c Students know that when the forces on an object are balanced, the motion of the object does not change.</p>	
<p>6. Explain Why is it difficult to make a car move by pushing it?</p>	
<p>_____</p>	
<p>_____</p>	
<p>_____</p>	

✓ **READING CHECK**

7. Explain Why is a golf ball easier to throw than a bowling ball?

SECTION 3 Newton's Laws of Motion *continued*

What Is Newton's Second Law of Motion?

Newton's second law of motion describes how an object moves when an unbalanced force acts on it. The second law has two parts:

1. The acceleration of an object depends on the mass of the object. If two objects are pushed or pulled by the same force, the object with the smaller mass will accelerate more. ✓
2. The acceleration of an object depends on the force applied to the object. If two objects have the same mass, the one you push harder will accelerate more.

READING CHECK

8. Apply Concepts Which object will accelerate more if the same force is applied to both: a pickup truck or a tractor-trailer truck?

PART 1: ACCELERATION AND MASS

The figure below shows how the mass of an object affects the acceleration. When the cart is empty, you have to exert only a small force on the cart to accelerate it. But when the cart is full, pushing with the same force makes the cart accelerate more slowly.

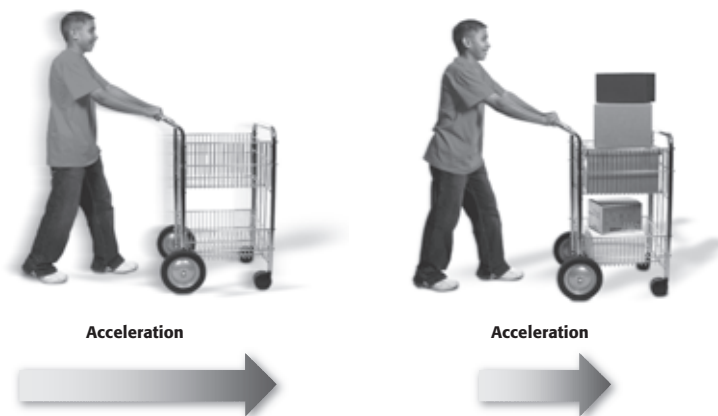

Length of the arrows shows the size of the cart's acceleration.

TAKE A LOOK

9. Describe What happens to the cart if the same force is applied but one cart is empty and the other is full?

SECTION 3 Newton's Laws of Motion *continued*

PART 2: ACCELERATION AND FORCE

You can understand the second part of Newton's second law using the same sort of situation. You can push harder on the loaded cart than the empty cart in order to give the cart the same acceleration. An object's acceleration increases as the force on the object increases. Similarly, an object's acceleration decreases as the force on the object decreases.

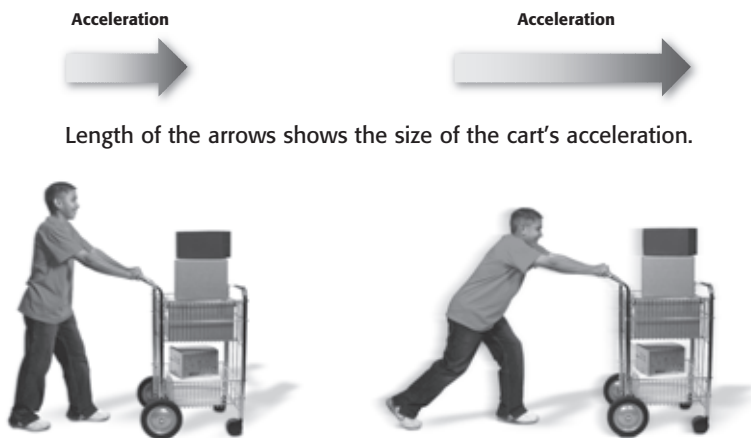

TAKE A LOOK

10. Describe What happens to the loaded cart if a larger force is exerted on it?

What Is Newton's Third Law of Motion?

All forces act in pairs. Whenever one object exerts a force on a second object, the second object exerts a force on the first object. The forces are always equal in size and opposite in direction. ✓

For example, when you sit on a chair, the force of your weight pushes down on the chair. At the same time, the chair pushes up on you with a force equal to your weight.

READING CHECK

11. Describe Object A pushes on object B. What does object B do to object A?

SECTION 3 Newton's Laws of Motion *continued*

ACTION AND REACTION FORCES

The figure below shows two forces acting when a person is sitting in a chair. The *action force* is the person's weight pushing down on the chair. The *reaction force* is the chair pushing back up on the person. These two forces together are known as a *force pair*.

Forces Acting When a Person Sits in a Chair

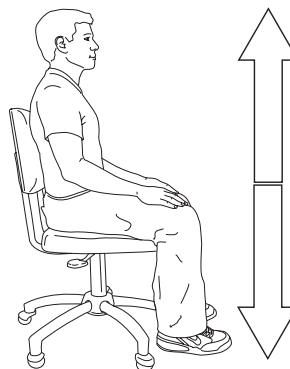

The chair pushes up on person.

The person's weight pushes down on chair.

TAKE A LOOK

12. Identify On the figure, label the action force and the reaction force.

Action and reaction forces are also present when there is motion. The figures below show some more examples of action and reaction forces.

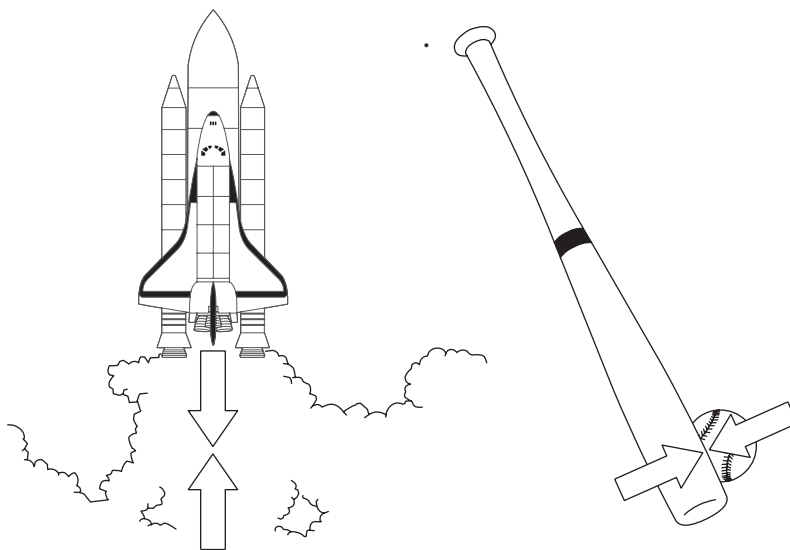

TAKE A LOOK

13. Describe How large is the size of the reaction force compared with the action force in the pictures?

The space shuttle's thrusters push gases downward. The gases push the space shuttle upward with equal force.

The bat exerts a force on the ball and sends the ball flying. The ball exerts an equal force on the bat.

Say It

Discuss What examples of pairs of forces do you notice in the classroom? What examples of pairs of forces at home can you think of?

The action force always acts on a different object from the reaction force. For example, when you sit in a chair, the action force (your weight) acts on the chair. However, the reaction force (the chair pushing on you) acts on you.

SECTION 3 Newton's Laws of Motion *continued***HARD-TO-SEE EFFECTS**

In the figure below, a ball is falling toward the Earth's surface. The action force is the Earth's gravity pulling down on the ball. What is the reaction force?



The force of gravity between Earth and a falling object is a force pair.

Believe it or not, the reaction force is the ball pulling up on Earth. Have you ever felt this reaction force when you've dropped a ball? Of course not. However, both forces are present. So, why don't you see or feel Earth rise?

To answer this question, recall Newton's second law. Acceleration depends on the mass and the force on an object. Earth and the ball have the same size force acting on them. But Earth has a very, very large mass. Because it has such a large mass, its acceleration is too small to see or feel. ✓

You can easily see the ball's acceleration because its mass is small compared with Earth's mass. Most of the objects that fall toward Earth's surface are much less massive than Earth. This means that you will probably never feel the effects of the reaction force when an object falls to Earth.

TAKE A LOOK

14. Identify On the figure, draw and label arrows showing the size and direction of the action force and the reaction force for the ball falling to the Earth.

 **READING CHECK**

15. Explain Why can't you feel the effect of the reaction force when an object falls to Earth?

Section 3 Review

SECTION VOCABULARY

inertia the tendency of an object to resist being moved or, if the object is moving, to resist a change in speed or direction until an outside force acts on the object

1. Identify When the force on an object is unbalanced, what three changes may occur in the object's velocity?

2. Fill In Complete the Concept Map. Use the following words to fill in the blank ovals: acceleration, inertia, friction, force.

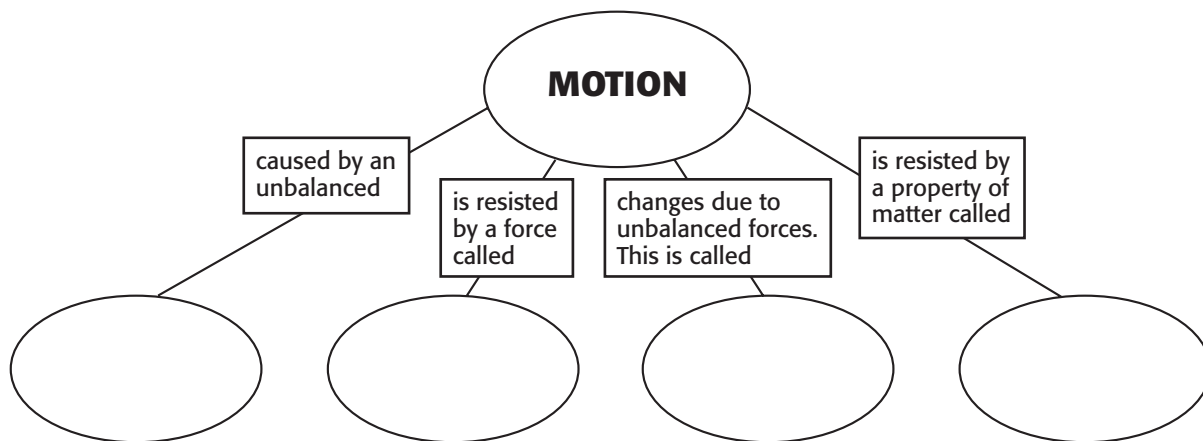

3. Identify Describe two things you can do to increase the acceleration of an object.

4. Describe When the forces on an object are balanced, describe the motion of the object.

5. Describe What would happen if there were no friction between a rolling ball and the ground?

6. Identify What are the action and reaction forces when you kick a soccer ball?

Fluids and Pressure

BEFORE YOU READ

After you read this section, you should be able to answer these questions:

- What are fluids?
- What is atmospheric pressure?
- What is water pressure?
- What causes fluids to flow?



California Science Standards

8.8.a

What Are Fluids?

You have something in common with a dog, a sea gull, and a dolphin. You and all these other animals spend a lifetime moving through fluids. A **fluid** is any material that can flow and that takes the shape of its container. Fluids have these properties because their particles can easily move past each other. Liquids and gases are fluids. ✓

Fluids produce pressure. **Pressure** is the force exerted on a given area. The motions of the particles in a fluid are what produce pressure. For example, when you pump up a bicycle tire, you push air into the tire. Air is made up of tiny particles that are always moving. When air particles bump into the tire, the particles produce a force on the tire. The force exerted on the area of the tire creates the air pressure inside the tire.

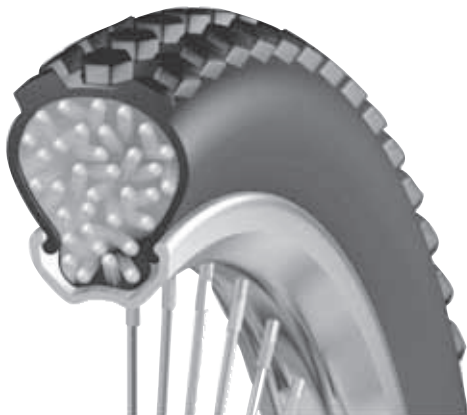

The air particles inside the tire hit the walls of the tire with a force. This force produces a pressure inside the tire. The pressure keeps the tire inflated.

STUDY TIP

Explain As you read this section, study each figure. In your notebook, describe what each figure tells you about pressure.

READING CHECK

1. **Identify** What is a fluid?

TAKE A LOOK

2. **Define** What is pressure?

PRESSURE AND BUBBLES

Why are bubbles (such as the ones in soda) round? It's because fluids (such as the gas inside the bubbles) exert the same pressure in all directions. This gives the bubbles their round shape.

SECTION 1 Fluids and Pressure *continued*

CALCULATING PRESSURE

Remember that pressure is a force exerted on an area. You can use this equation to calculate pressure:

$$pressure = \frac{force}{area}$$

The SI unit of force is the pascal. One **pascal** (Pa) is equal to a force of one newton pushing on an area of one square meter (1 N/m²). A pressure of 1 Pa is very small. A feather exerts more pressure on a table than 1 Pa. Therefore, scientists usually give pressures in kilopascals (kPa). So, 1 kPa equals 1,000 Pa.

Let's calculate a pressure. What is the pressure produced by a book that has an area of 0.2 m² and a weight of 10 N? Solve pressure problems using the following procedure:

Step 1: Write the equation. $pressure = \frac{force}{area}$

Step 2: Substitute and solve. $= \frac{10\text{ N}}{0.2\text{ m}^2} = 50 \frac{\text{N}}{\text{m}^2} = 50\text{ Pa}$

What Is Atmospheric Pressure?

The atmosphere is the layer of gases that surrounds Earth. Gravity holds the atmosphere in place. The pull of gravity gives air weight. The pressure caused by the weight of the atmosphere is called **atmospheric pressure**.

Atmospheric pressure is exerted on everything on Earth, including you. At sea level, the pressure is about 101,300 Pa (101.3 kPa). This means that every square centimeter of your body has about 10 N (2 lb) of force pushing on it.

Why doesn't your body collapse under this pressure? Like the air in a balloon, the fluids inside your body exert pressure. This pressure inside your body acts against the atmospheric pressure.

Math Focus

3. Calculate What pressure is exerted by a crate with a weight of 3,000 N and an area of 2 m²? Show your work.

TAKE A LOOK

4. Describe What would be the length of the arrows if the balloon were inflated more? Explain your answer.

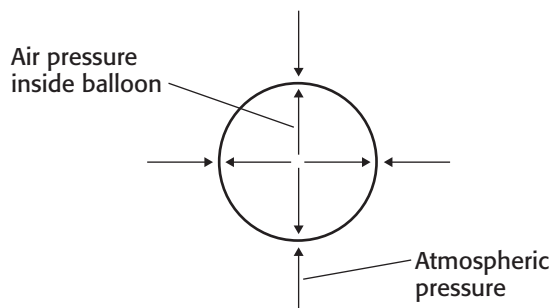

The air inside the balloon produces a pressure inside the balloon. The pressure inside the balloon equals the atmospheric pressure outside the balloon. Therefore, the balloon stays inflated.

SECTION 1 Fluids and Pressure *continued*

PRESSURE, ALTITUDE, AND DEPTH

It is very difficult to climb Mount Everest. One reason is that there is not very much air at the top of Mount Everest. The atmospheric pressure on top of Mount Everest is only about one-third of that at sea level. As you climb higher, the pressure gets lower and lower. At the top of the atmosphere, the pressure is almost 0 Pa. ✓

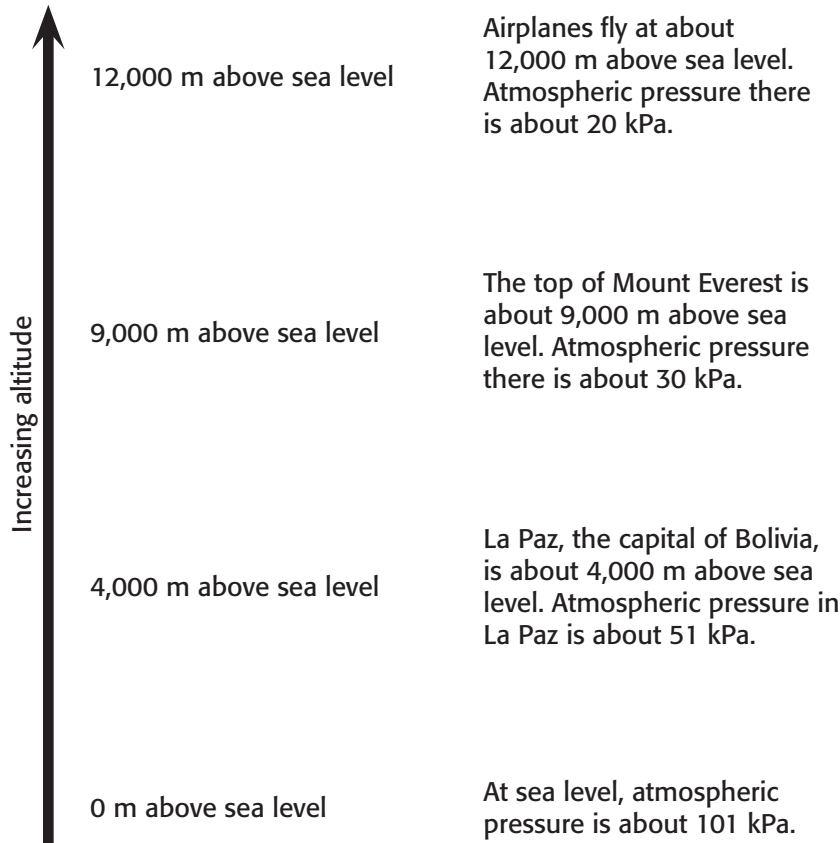

✓ **READING CHECK**

5. Describe What happens to atmospheric pressure as altitude increases?

Math Focus

6. Calculate About what fraction of atmospheric pressure at sea level is atmospheric pressure at La Paz?

Air pressure is greatest at Earth’s surface because the entire weight of the atmosphere is pushing down there. This is true for all fluids. As you get deeper in a fluid, the pressure gets larger. You can think of being at sea level as being “deep” in the atmosphere. ✓

PRESSURE CHANGES AND YOUR BODY

What happens to your body when atmospheric pressure changes? You may have felt your ears “popping” when you are in an airplane or in a car climbing a mountain. Air chambers behind your ears help to keep the pressure in your ears equal to air pressure. The “pop” happens because the pressure inside your ears changes as air pressure changes.

✓ **READING CHECK**

7. Explain Why is atmospheric pressure greatest at the surface of Earth?

SECTION 1 Fluids and Pressure *continued*

What Affects Water Pressure?

Water is a fluid. Therefore, it exerts a pressure. Water pressure increases as depth increases, as shown in the figure below. The pressure increases as the diver gets deeper because more and more water is pushing on her. In addition, the atmosphere pushes down on the water. Therefore, the total pressure on the diver is the sum of the water pressure and the atmospheric pressure. ✓

READING CHECK

8. Explain Why does pressure increase as depth increases?

Say It

Discuss In a small group, talk about the kinds of adaptations that deep-water organisms, such as the viper fish, may have to help them survive at very high water pressures.

TAKE A LOOK

9. Infer Based on the information in the figure, about how much pressure is exerted by 10 m of water?

The pressure exerted on a diver 10 m below the water's surface is twice the pressure at the surface.

At 500 m below the surface, pressure is about 5,000 kPa. Divers at or below this level must wear special suits to survive the pressure.

The wreck of the *Titanic* is 3,660 m below the surface. The water pressure at this depth is 36,600 kPa.

The viper fish lives 8,000 m below the ocean's surface. No fish are found below this level. Water pressure at this depth is 80,000 kPa.

In 1960, the *Trieste* descended to the deepest part of the ocean (11,000 m), where the pressure is 110,000 kPa.

DENSITY EFFECTS ON WATER PRESSURE

Density is a measure of how closely packed the particles in a substance are. It is a ratio of the mass of an object to its volume. Water is about 1,000 times denser than air. A certain volume of water has more mass (weighs more) than the same volume of air. Therefore, water exerts more pressure than air. The pressure exerted by 10 m of water is almost the same as the pressure exerted by the whole atmosphere.

SECTION 1 Fluids and Pressure *continued*

What Causes Fluids to Flow?

All fluids flow from areas of high pressure to areas of low pressure. Imagine a straw in a glass of water. Before you suck on the straw, the air pressure inside the straw is equal to the air pressure on the water. When you suck on the straw, the air pressure inside the straw decreases. However, the pressure on the water outside the straw stays the same. The pressure difference forces water up the straw and into your mouth.

PRESSURE DIFFERENCE AND BREATHING

The flow of air from high pressure to low pressure is also what allows you to breathe. When you inhale, a muscle in your chest moves down. This makes the volume of your chest bigger, so your lungs have more room to expand. As your lungs expand, the pressure inside them goes down. Atmospheric pressure is now larger than the pressure inside your lungs, so air flows into your lungs. The figure below shows the reverse process when you exhale.

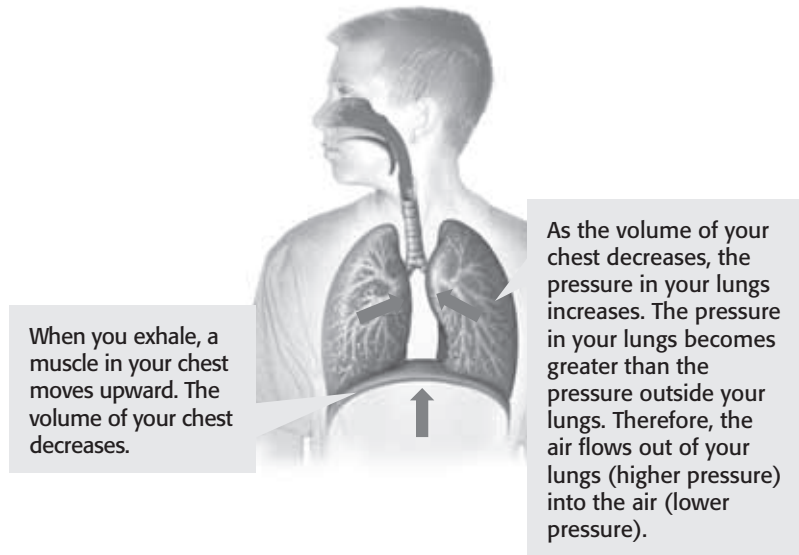

Critical Thinking

10. Apply Concepts Why does the air pressure inside a straw go down when you suck on the straw?

TAKE A LOOK

11. Explain Why does air flow out of your lungs when you exhale?

PRESSURE DIFFERENCES AND TORNADOES

During a tornado, wind speeds can reach 300 miles per hour or more! Some of the damaging winds caused by a tornado are due to pressure differences. The air pressure inside a tornado is very low. Because the air pressure outside the tornado is high, the air rushes into the tornado and produces strong winds. The winds cause the tornado to act as a giant vacuum cleaner. Objects are pulled in and lifted up by these winds.

Section 1 Review

SECTION VOCABULARY

atmospheric pressure the pressure caused by the weight of the atmosphere

fluid a nonsolid state of matter in which the atoms or molecules are free to move past each other, as in a gas or liquid

pascal the SI unit of pressure (symbol, Pa)

pressure the amount of force exerted per unit area of a surface

Wordwise The root *press* means “to press.”

1. Describe How do fluids exert pressure on a container?

2. Evaluate Define density in terms of mass and volume. How does density affect pressure?

3. Calculate The water in a glass has a weight of 2.5 N. The bottom of the glass has an area of 0.012 m². What is the pressure exerted by the water on the bottom of the glass?

4. Describe Fill in the blank spaces in the chart below to show how air moves in and out of your lungs when you breathe.

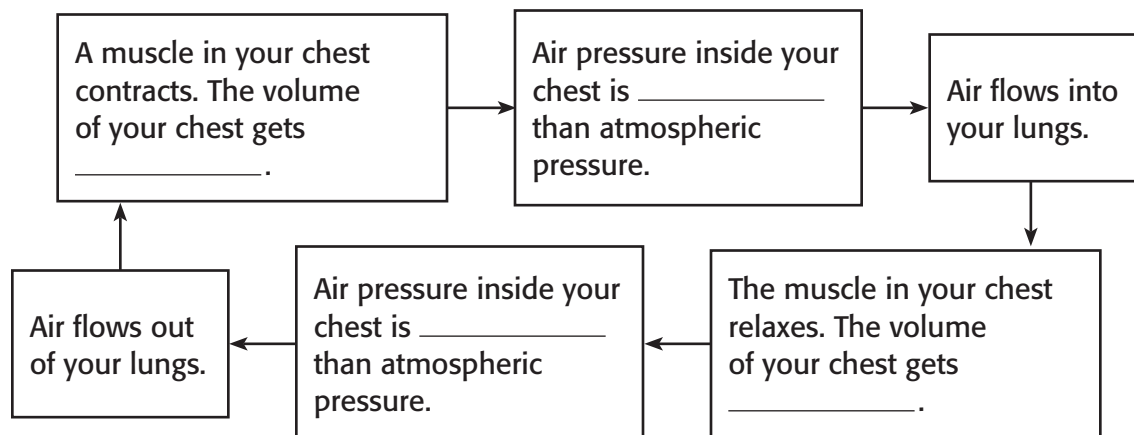

Buoyancy and Density

BEFORE YOU READ

After you read this section, you should be able to answer these questions:

- What is buoyant force?
- What makes objects sink or float?
- How is density calculated?



California Science Standards

8.8.a, 8.8.b, 8.8.c, 8.8.d

What Is Buoyant Force?

Why does an ice cube that has been pushed under the water pop back up? A force called buoyant force pushes the ice cube up to the water's surface. **Buoyant force** is the upward force that a fluid exerts on all objects in the fluid.

Look at the figure below. Water exerts a pressure on all sides of the object in the water. The water produces the same amount of horizontal force on both sides of the object. These equal forces balance one another.

However, the vertical forces are not equal. Remember that fluid pressure increases with depth. There is more pressure on the bottom of the object than on the top. ✓

The longer arrows in the figure below show the larger pressures. You can see that the arrows are longest underneath the object. This shows that the water applies a net upward force on the object. This upward force is buoyant force. It is what makes the object float.

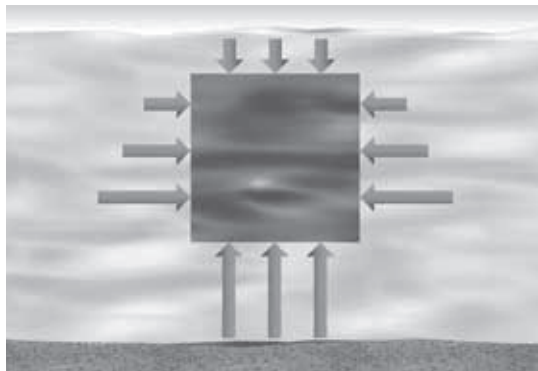

There is more pressure at the bottom of an object because pressure increases with depth. The differences in pressure produce an upward buoyant force on the object.

Buoyant force is what makes you feel lighter when you float in a pool of water. The buoyant force of the water pushes up on your body and reduces your weight.

STUDY TIP

Learn New Words As you read, underline words you don't understand. When you figure out what they mean, write the words and their definitions in your notebook.

READING CHECK

1. Identify Why is the force on the bottom of an object in a fluid larger than the force on the top?

TAKE A LOOK

2. Identify What produces buoyant force?

SECTION 2 Buoyancy and Density *continued***CALIFORNIA STANDARDS CHECK**

8.8.c Students know the buoyant force on an object in a fluid is an upward force equal to the weight of the fluid the object has displaced.

Word Help: **displace** to take the place of; to move aside

3. Apply Ideas A can of soda displaces about 360 mL of water when it is put in a cooler of water. The weight of 360 mL of water is about 3.6 N. What is the buoyant force on the can of soda?

TAKE A LOOK

4. Compare How is the volume of water that the metal cylinder displaces related to the volume of the metal cylinder?

DETERMINING BUOYANT FORCE

Archimedes, a Greek mathematician who lived in the third century BCE, discovered how to find buoyant force. Archimedes found that objects in water *displace*, or take the place of, water. The weight of the displaced water equals the buoyant force of the water. This is now known as **Archimedes' principle**.

You can find buoyant force by measuring the weight of the water that an object displaces. Suppose the block in the figure below displaces 250 mL of water. The weight of 250 mL of water is about 2.5 N. The weight of the displaced water equals the buoyant force. Therefore, the buoyant force on the block is 2.5 N.

The buoyant force pushes up on the block and reduces its weight. Suppose the block weighs 4 N. When the block is in the water, its weight is reduced by 2.5 N. Therefore, the block in the water weighs $4\text{ N} - 2.5\text{ N} = 1.5\text{ N}$.



When a metal cylinder is put into a container of water, the cylinder displaces some water. The weight of the displaced water equals the buoyant force on the cylinder.

Imagine that you want to measure the buoyant force on a second block. However, you cannot measure how much water the block displaces. You can determine the buoyant force by measuring how much the block's weight changes when it is placed underwater.

First, measure the weight of the block by hanging it from a spring scale. Next, lower the block into the water. Read the weight of the block in the water from the spring scale. The buoyant force is equal to the change in the block's weight when it is placed underwater.

For example, suppose the block weighs 5 N out of the water and 3 N in the water. The buoyant force on the block is $5\text{ N} - 3\text{ N} = 2\text{ N}$.

SECTION 2 Buoyancy and Density *continued*

What Makes Objects Float or Sink?

An object in a fluid will sink if its weight is greater than the buoyant force. An object floats only when the buoyant force is equal to or less than the object’s weight. ✓

SINKING, FLOATING, AND BUOYING UP

The rock in the figure below weighs 75 N. It displaces 5 L, or about 50 N, of water. According to Archimedes’ principle, the buoyant force is about 50 N. Since the weight of the rock is greater than the buoyant force, the rock sinks.

The fish in the figure weighs 12 N. It displaces a volume of water that weighs 12 N. The buoyant force and the fish’s weight are equal, so the fish floats in the water. It does not sink to the bottom or rise to the surface—it is *suspended* in the water.

The duck in the figure weighs 9 N. If the duck’s body was completely underwater, it would displace a volume of water that weighs more than 9 N. Therefore, the buoyant force on the duck is greater than the duck’s weight. The buoyant force causes the duck to be *buoyed up*, or pushed toward the surface.

An object is buoyed up until the part underwater displaces an amount of water that equals the object’s weight. Therefore, the part of the duck that is underwater displaces 9 N of water.

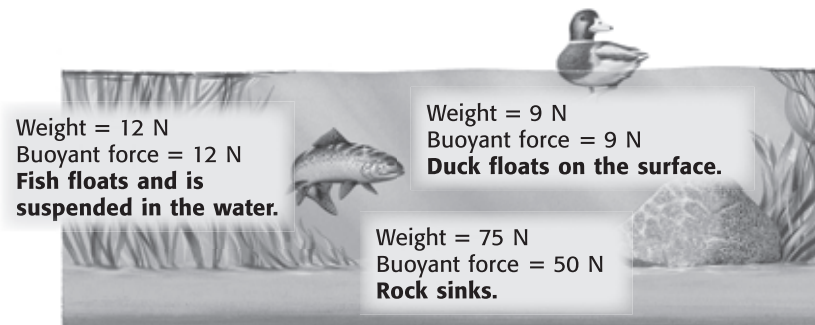

Situation	Size of the buoyant force	Result
The object’s weight is greater than the weight of the water it displaces.	less than the weight of the object	The object sinks.
The object’s weight is equal to the weight of the water it displaces.	equal to the weight of the object	The object floats.
The object’s weight is less than the weight of the water it displaces.	greater than the weight of the object	The object is buoyed up.

✓ **READING CHECK**

5. Identify Will an object sink or float if its weight is less than the buoyant force?

Critical Thinking

6. Apply Concepts If the duck weighed 10 N, would more or less of the duck be underwater?

TAKE A LOOK

7. Explain Why does the fish float in the middle of the water?

SECTION 2 Buoyancy and Density *continued*

How Does Density Affect Floating?

Remember that *density* is the mass of an object divided by its volume. An object will sink in a fluid if the object's density is greater than the density of the fluid. An object will float in a fluid if the object's density is less than the density of the fluid. If the fluid and the object have the same density, the object will be suspended in the fluid. ✓

Think again about the rock in the water. How does the density of the rock compare to the density of water? The volume of the rock is 5 L, and it displaces 5 L of water. The weight of the rock is 75 N, and the weight of 5 L of water is 50 N. The weight of an object is a measure of its mass. In the same volume, the rock has more mass than water. Therefore, the rock is more dense than water.

The rock sinks because it is denser than water. The duck floats because it is less dense than water. The fish floats suspended in the water because it has the same density as the water. ✓

READING CHECK

8. Define What is density?

READING CHECK

9. Explain How does an object's density determine whether it floats or sinks?

MORE DENSE THAN AIR

Why does an ice cube float on water but not in air? An ice cube floats in water because it is less dense than water. However, most substances are more dense than air. The ice cube is more dense than air, so it does not float in air.

LESS DENSE THAN AIR

One substance that is less dense than air is helium, a gas. When a balloon is filled with helium, the filled balloon becomes less dense than air. Therefore, the balloon floats in air, like the one in the figure below.



This balloon floats because the helium in it is less dense than air.

TAKE A LOOK

10. Infer The balloon in the picture is filled with about 420,000 L of helium.

Does 420,000 L of air have a greater or smaller mass than the 420,000 L of helium in the balloon? Explain your answer.

SECTION 2 Buoyancy and Density *continued*

How Is Density Calculated?

To determine the density of an object, you need to know its mass and volume. Use the following equation:

$$\text{density} = \frac{\text{mass}}{\text{volume}}$$

Let's see how to do a density problem. Find the density of a rock that has a mass of 10 g and a volume of 2 cm³.

Step 1: Write the equation. $\text{density} = \frac{\text{mass}}{\text{volume}}$

Step 2: Substitute and solve. $d = \frac{10 \text{ g}}{2 \text{ cm}^3} = 5 \text{ g/cm}^3$

You can measure the mass of an object using a balance. To find its volume, use one of the methods below.

Math Focus

11. Calculate Find the density of a gold coin that has a mass of 180 g and a volume of 10 cm³.

FINDING VOLUME OF A RECTANGULAR SOLID

Some objects, such as shoeboxes, are shaped like cubes or rectangular blocks. To find the volume of one of these objects, use a ruler to measure the length of each side. Multiply the three lengths together to find the object's volume.

Volume of a Regular Solid

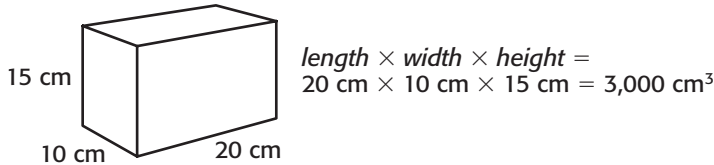

FINDING VOLUME OF AN IRREGULAR SOLID

Many things do not have a rectangular shape. You can find the volume of one of these objects using water displacement. To do this, place the object into a known volume of water. Then, measure how much the volume of the water changed when the object was added. The change in volume is equal to the volume of the object. ✓

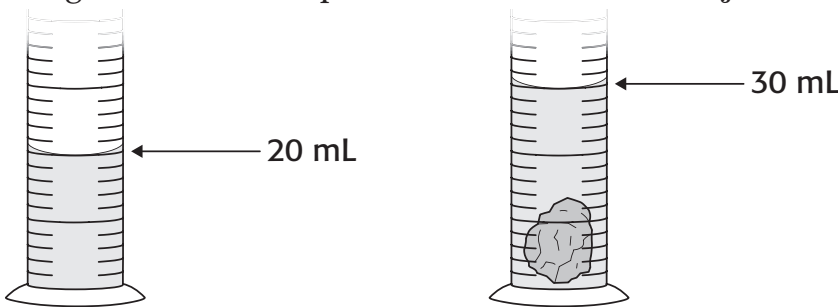

You can find the volume of an irregular object by water displacement. The volume of the object in the figure is 10 mL.

READING CHECK

12. Explain Why should you use water displacement to find the volume of an irregular solid?

SECTION 2 Buoyancy and Density *continued*

What Affects an Object’s Density?

The total density of an object can change if its mass or volume changes. If volume increases and mass stays the same, density decreases. If mass increases and volume stays the same, density increases.

CHANGING SHAPE

Steel is almost eight times denser than water. Yet huge steel ships cruise the oceans with ease. If steel is more dense than water, how can these ships float? The reason a steel ship floats has to do with its shape. If the ship were just a big block of steel, it would sink very quickly. However, ships are built with a hollow shape. The hollow shape increases the volume that the steel takes up without increasing the mass of the steel.

TAKE A LOOK

13. Compare What is the volume of the ship compared to the volume of the steel used to make the ship?



A block of steel is denser than water, so it sinks. If that block is shaped into a hollow form, the overall density of the form is less than water. Therefore, the ship floats.

Increasing the volume of the steel produces a decrease in its density. When the volume of the ship becomes large enough, the overall density of the ship becomes less than water. Therefore, the ship floats. ✓

✓ READING CHECK

14. Explain How can changing the shape of an object lower its overall density?

Most ships are built to displace more water than is necessary for the ship to float. Ships are made this way so that they won’t sink when people and cargo are loaded onto the ship.

CHANGING MASS

A submarine is a ship that can travel both on the surface of the water and underwater. Submarines have *ballast tanks* that can open to let seawater flow in. When seawater flows in, the mass of the submarine increases. Therefore, its overall density increases. When seawater is pushed out, the overall density of the submarine decreases.

SECTION 2 Buoyancy and Density *continued*



Water flows into the ballast tanks. The submarine becomes more dense and sinks.

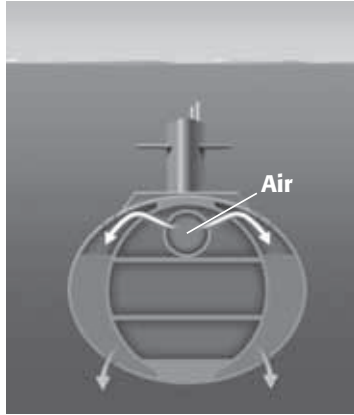

Compressed air forces water out of the ballast tanks. The submarine becomes less dense and floats to the surface.

TAKE A LOOK

15. Describe How does a submarine increase its density?

CHANGING VOLUME

Some fish can change their overall density by changing their volume. Most bony fish have an organ called a *swim bladder*. This swim bladder can fill with gases or release gases. The gases are less dense than the rest of the fish. When gases go into the swim bladder, the overall volume of the fish increases, but the mass of the fish does not change as much. This lowers the overall density of the fish and keeps it from sinking in the water. ✓

The fish's nervous system controls the amount of gas in the bladder. Some fish, such as sharks, do not have a swim bladder. These fish must swim constantly to keep from sinking.

READING CHECK

16. Explain How do most bony fish change their overall density?

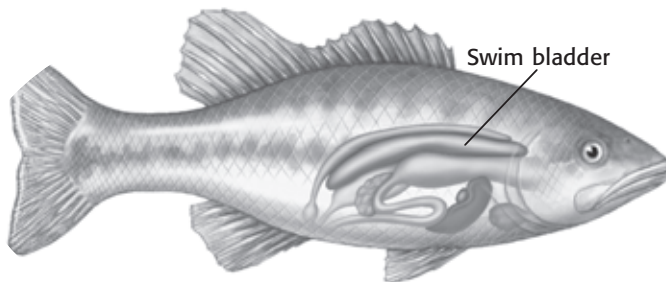

Most bony fish have a swim bladder, an organ that allows them to adjust their overall density.

Section 2 Review

8.8.a, 8.8.b, 8.8.c, 8.8.d



SECTION VOCABULARY

Archimedes' principle the principle that states that the buoyant force on an object in a fluid is an upward force equal to the weight of the volume of fluid that the object displaces

buoyant force the upward force that keeps an object immersed in or floating on a liquid

- 1. Predict** In the left-hand figure, a block of wood is floating on the surface of some water. In the right-hand figure, the block of wood is pushed beneath the surface of the water. In the space below, predict what will happen to the wood when the force in the right-hand figure is removed. Use the term *buoyant force* in your answer.

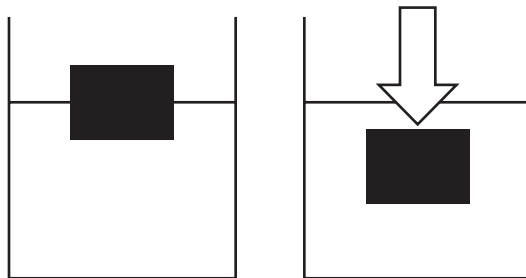

- 2. Calculate** A container that is filled with mercury has a mass of 4,810 g. If the volume of the container is 355 mL, what is its overall density? Show your work. Round your answer to the nearest tenth.

- 3. Identify** Give two ways that an object's overall density can change.

- 4. Explain** How can knowing an object's density help you to predict whether the object will float or sink in a fluid?

CHAPTER 15 Stars, Galaxies, and the Universe

SECTION 1 Stars

BEFORE YOU READ

After you read this section, you should be able to answer these questions:

- Why are stars different colors?
- How can scientists learn what stars are made of?
- How can we measure the distance between stars?
- Why do stars seem to move across the sky?



California Science Standards

8.4.b, 8.4.c, 8.4.d

Why Are Stars Different Colors?

A star is a bright ball of burning gas. If you look closely at the night sky, you might see that stars are different colors. Scientists can tell how much heat a star gives off by studying its color.

Compare the yellow flame of a candle to the blue flame of a Bunsen burner. A blue flame is much hotter. Stars are similar: blue stars burn hotter than yellow ones. Red stars are coolest.



A blue flame is hotter than a yellow one.

STUDY TIP

Ask Questions Read this section silently. Write down questions that you have about this section. Discuss your questions in a small group.

TAKE A LOOK

1. Color Use colored pencils to make these flames the correct color.

2. Identify Which of the flames is cooler?

What Are Stars Made Of?

Stars are made of gas. Hydrogen and helium are the two main elements that make up a star. Stars also contain small amounts of other elements, such as carbon, nitrogen, and oxygen. Each star is made up of a different mix of elements.

Most stars are trillions of miles away from Earth. Because scientists cannot visit the stars, they need to study them from Earth. To find out what a star is made of, scientists study the light from stars. ✓

READING CHECK

3. Explain How do scientists learn about stars?

SECTION 1 Stars *continued*

Critical Thinking

4. Apply Concepts When we look at the night sky, are we seeing the universe exactly as it is?

How Can Scientists Learn About Stars from Their Light?

Light takes time to travel through space. Stars are so far away that their light takes millions of years to travel to Earth! When scientists look through telescopes, it is as if they are looking back in time. The light we see from stars today was made millions of years ago. Some stars that we see might have already burned out. However, we can still see them because their light is just reaching Earth.

What Can Scientists Learn from a Star’s Light?

Scientists use the light from stars to find out what the stars are made of. When you look at white light through a glass prism, you can see a rainbow of colors. This rainbow is called a **spectrum**. Millions of colors make up a spectrum, including red, orange, yellow, green, blue, indigo, and violet. Scientists use a machine called a *spectroscope* to break up a star’s light into a spectrum.

Each element has a distinctive pattern of lines that appear in an *emission spectrum*. The emission spectrum shows scientists what elements are in the star.

TAKE A LOOK

5. Complete Four colors are found in the emission spectrum for hydrogen. From left to right, these colors are purple, blue, green, and red. Use colored pencils to show how this spectrum should look.



How Are Stars Classified?

Stars can be classified in several ways. Scientists classify stars most commonly by temperature and brightness.

TEMPERATURE

In the past, scientists classified stars by the elements they contained. Today, stars are classified by temperature. Each group of stars is named with a letter of the alphabet.

SECTION 1 Stars *continued*

Class	Color	Temperature (°C)	Elements detected
O	blue	above 30,000	helium
B	blue-white	10,000 to 30,000	hydrogen, helium
A	blue-white	7,500 to 10,000	hydrogen
F	yellow-white	6,000 to 7,500	hydrogen and heavier elements
G	yellow	5,000 to 6,000	calcium and heavier elements
K	orange	3,500 to 5,000	calcium and iron
M	red	less than 3,500	molecules, such as titanium dioxide

TAKE A LOOK

6. Identify If you just discovered a star that was blue-white in color and made of hydrogen, which class would you put it in?

7. Identify Which class has hotter stars—G or B?

BRIGHTNESS

A second way of classifying stars is by brightness. Before telescopes were invented, scientists judged the brightness of the stars with their naked eyes. They called the brightest stars they could see first-magnitude stars, and the dimmest stars, sixth-magnitude stars.

When telescopes were developed, scientists discovered this system had flaws. They could see more stars with the telescope than with the naked eye. They could also see the differences in brightness more clearly. The old system for classifying brightness was too general to include the dimmest stars that scientists were finding. A new system had to be created.

Today, scientists give each star a number to show its brightness, or *magnitude*. The dimmest stars have the largest numbers. The brightest stars have the smallest numbers. The magnitude of a very bright star can even be a negative number! ✓

Magnitudes of Stars in the Big Dipper

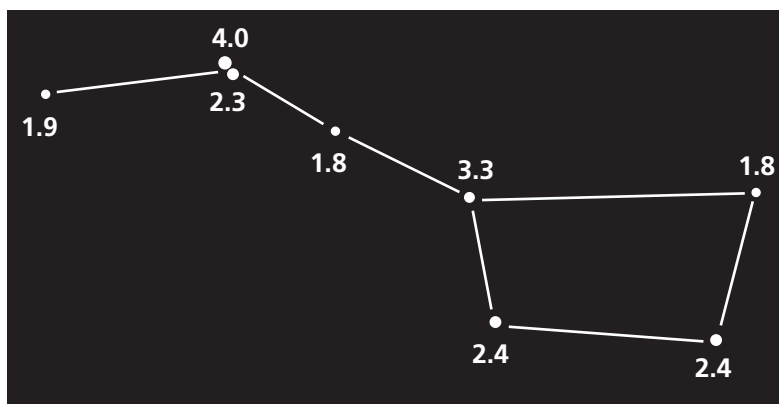
**READING CHECK**

8. Identify Which star is brighter: one with a magnitude of 6.3 or one with a magnitude of -1.4 ?

TAKE A LOOK

9. Identify Circle the brightest stars in the Big Dipper. What is their magnitude?

SECTION 1 Stars *continued***Does Distance Change a Star's Brightness?**

If you look at a row of street lights, do all of the lights look the same? The nearest lights look brightest, and the farthest ones look dimmest.



The closer a light is, the brighter it looks.

TAKE A LOOK

10. Identify Circle the dimmest light in the picture. Put a box around the brightest light.

11. Explain The street lights are all equally bright. Why do they appear different?

The brightness of a star as we see it from Earth is the star's **apparent magnitude**. A bright star can look very dim if it is very far away from Earth. A dim star can appear bright if it is closer to Earth.

A star's **absolute magnitude** is the brightness that a star would have if it were 32.6 light-years away from Earth. If all stars were the same distance away, their absolute magnitudes would equal their apparent magnitudes. For example, the sun's absolute magnitude is +4.8, but because it is close to Earth, its apparent magnitude is -26.8.

How Do Scientists Measure Distance to a Star?

The distance between Earth and the stars is too large to be measured in miles or kilometers. Instead, scientists use a unit called a **light-year**, which is the distance that light can travel in one year. One light year equals 9.46 trillion kilometers. How can scientists measure such a large distance?

As Earth revolves around the sun, stars close to Earth seem to move, but far-off stars do not. This is called **parallax**. Scientists use parallax and math to find the distance between Earth and stars. You can demonstrate parallax by holding your thumb out in front of you and closing one eye. Cover an object in the distance with your thumb. Open your eye and close the other. The object you covered seems to have moved!

Math Focus

12. Calculate What is the distance in kilometers from Earth to a star that is 30 light years away?

SECTION 1 Stars *continued*

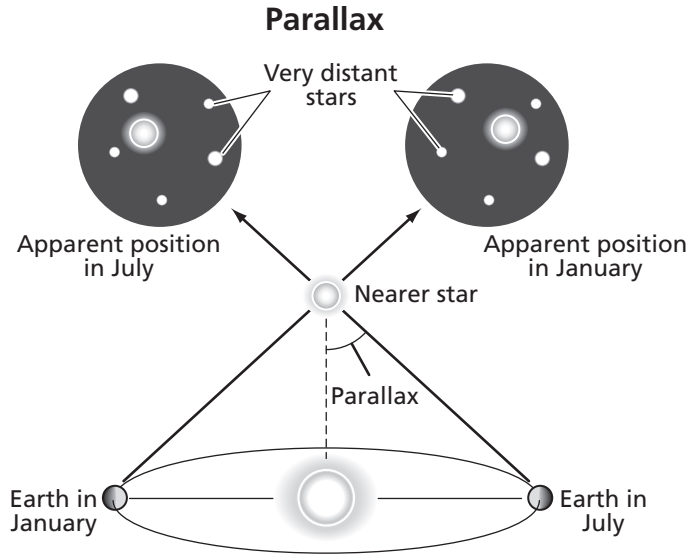

As the Earth revolves around the sun, a star's position seems to change.

TAKE A LOOK

13. Explain What causes parallax?

Do Stars Move?

Stars move, but because they are so far away and move so slowly, we cannot see their movement easily. Every night stars seem to rise and set, but it is not the stars that are moving. It is the Earth.

The rotation of Earth causes daytime and nighttime. Because of Earth's rotation, the sun moves across the sky during the daytime. For this same reason, the stars seem to move across the sky at night. All of the stars that you see appear to rotate around Polaris, the North Star. The stars seem to make a full circle around Polaris every 24 hours. ✓

Earth's tilt and revolution cause the seasons. During each season, Earth faces a different part of the sky at night. That means that different stars appear in the night sky at different times of the year.

READING CHECK

14. Summarize Why do stars seem to move at night?

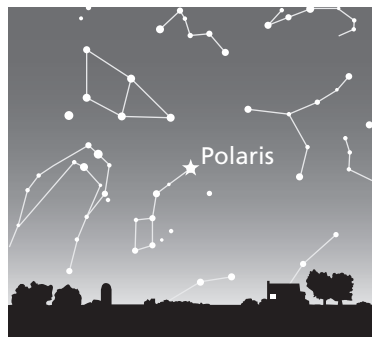
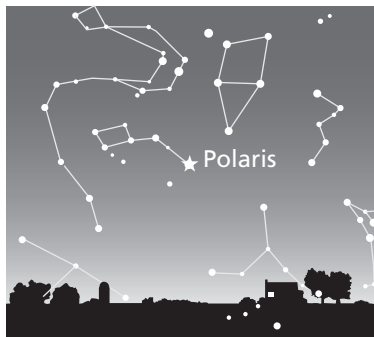

TAKE A LOOK

15. Compare Circle one star in the picture on the left. Then circle that star in the picture on the right. Draw a curved arrow in the first picture that shows the direction that the star seemed to move.

Section 1 Review

8.4.b, 8.4.c, 8.4.d



SECTION VOCABULARY

absolute magnitude the brightness that a star would have at a distance of 32.6 light-years from Earth

apparent magnitude the brightness of a star as seen from Earth

light-year the distance that light travels in one year; about 9.46 trillion kilometers

parallax an apparent shift in the position of an object when viewed from different locations

spectrum the band of colors produced when white light passes through a prism

1. Identify What are the two main elements that make up a star?

2. Analyze Why do scientists use light-years to show how far a star is from Earth?

3. Explain Why do stars seem to move in the sky?

4. Compare What is the difference between apparent magnitude and absolute magnitude?

5. Explain Why is the actual movement of stars hard to see?

6. Describe Describe two ways that a Class B star differs from a Class K star.

The Life Cycle of Stars

BEFORE YOU READ

After you read this section, you should be able to answer these questions:

- How do stars change over time?
- What is an H-R diagram?
- What may a star become after a supernova?



California Science Standards

8.4.b

How Do Stars Age?

Stars do not remain the same forever. Like living things, stars go through a life cycle from birth to death. The actual life cycle of a star depends on its size. An average star, such as the sun, goes through the stages shown below.

1. Protostar A protostar is a ball of gas and dust. Gravity pulls the gas and dust together, and its center gets hotter.



2. Main-Sequence Star The main sequence is the longest stage of a star's life cycle. The fusion of hydrogen atoms makes energy in the star.



3. Red Giant When a main sequence star uses up all its hydrogen it can no longer give off energy. The star's center contracts and the outer layers expand and cool.



4. White Dwarf A white dwarf is the leftover center of a red giant. It is a small, hot, and dim star that can shine for billions of years.



Organize Make a chart describing the life cycles of average stars and massive stars.

Critical Thinking

1. Analyze Concepts

Scientists can't watch a star through its entire life. A star can live for billions of years! How do you think scientists figure out the life cycle of a star?

TAKE A LOOK

2. Identify This star is in the last stage of its life cycle. What is that stage?

SECTION 2 The Life Cycle of Stars *continued*

What Is an H-R Diagram?

An **H-R diagram** is a graph that shows the relationship between a star's temperature and brightness. The H-R diagram also shows how stars change over time. The graph is named after Ejnar Hertzsprung and Henry Norris Russell, the scientists who made it. ✓

READING CHECK

3. Identify To make an H-R diagram, which two characteristics of a star must a scientist measure?

Temperature is given along the bottom of the diagram. Hotter stars are on the left, and the cooler stars are on the right. Brightness, or absolute magnitude, is given along the left side of the diagram. Bright stars are near the top, and dim stars are near the bottom.

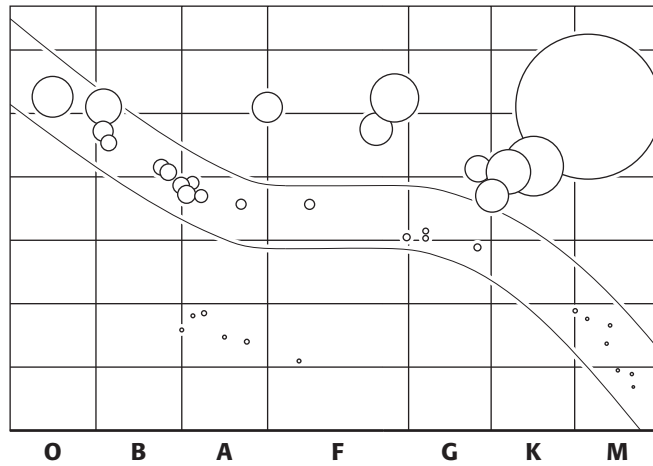

Main-sequence Stars
Stars on the main sequence form a band that runs across the H-R diagram. The sun is a main-sequence star. The sun has been shining for about 5 billion years. Scientists think that the sun is in the middle of its life and will remain on the main sequence for another 5 billion years.

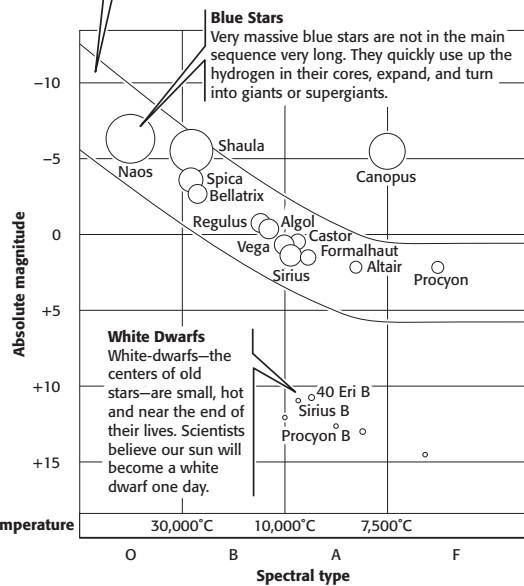

TAKE A LOOK

4. Identify Where in the H-R diagram are the brightest stars located?

5. Identify Where in the diagram are the hottest stars located?

An H-R diagram can show the life cycle of a star.

SECTION 2 The Life Cycle of Stars *continued*

Why Does a Star's Position on the H-R Diagram Change?

The bright line on the H-R diagram is called the **main sequence**. A star spends most of its life on the main sequence. As a main-sequence star ages, it becomes a red giant. When this happens, the star moves to a new place on the H-R diagram. The star's position on the diagram will change again when it becomes a white dwarf. These changes are made because the brightness and temperature of a star change throughout its life. ✓

Continuation of the H-R Diagram

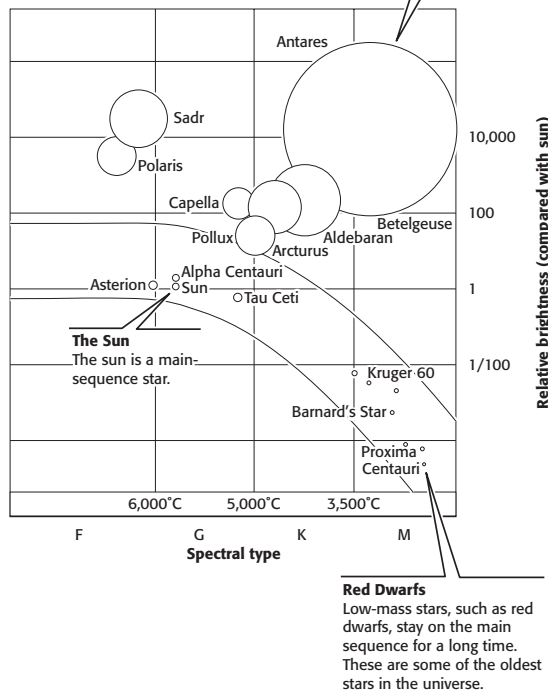

READING CHECK

6. Explain Why does a star's position on the H-R diagram change at different stages of its life cycle?

TAKE A LOOK

7. Compare Which star is hotter—Antares or Polaris?

8. Explain Is Betelgeuse on the main sequence?

What Happens to Massive Stars as They Age?

Massive stars use up their hydrogen much more quickly than smaller stars. As a result, massive stars give off much more energy and are very hot. However, they do not live as long as other stars. Toward the end of its main sequence, a massive star collapses in a gigantic explosion called a **supernova**. After such an explosion, a massive star may become a neutron star, a pulsar, or a black hole. ✓

READING CHECK

9. Identify What can cause a main-sequence star to turn into a neutron star, a pulsar, or a black hole?

SECTION 2 The Life Cycle of Stars *continued*

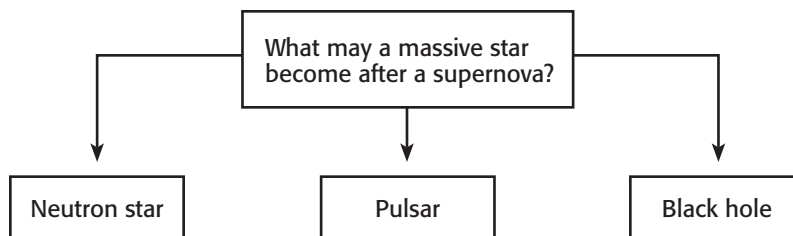

Critical Thinking

10. Explain Could an average star, such as our sun, become a neutron star? Explain your answer.

NEUTRON STARS

After a supernova, the center of a collapsed star may contract into a tiny ball of neutrons. This ball, called a *neutron star*, is extremely dense. On Earth, a single teaspoon of matter from a neutron star would weigh 100 million metric tons!

PULSARS

If a neutron star is spinning, it is called a *pulsar*. Pulsars send out beams of radiation that sweep through space. A radio telescope, an instrument that can pick up radiation with long wavelengths, can detect a pulsar. Every time a pulsar’s beam sweeps by Earth, scientists hear rapid clicks, or pulses, in the radio telescope.

BLACK HOLES

If the collapsed star is extremely massive, the force of its gravity may cause it to contract even more. This contraction crushes the dense center of the star, creating a *black hole*. Even though they are called holes, black holes aren’t really empty spaces. A black hole is an object so dense that even light cannot escape its gravity.

Because black holes do not give off light, it can be hard for scientists to locate them. Gas and dust from a nearby star may fall into the black hole and give off X rays. When scientists find these X rays, they can infer that a black hole is close by.

 **Say It**

Discuss In small groups, talk about other places you have heard about X rays. Where were they used, and what were they used for?

Section 2 Review

SECTION VOCABULARY

<p>H-R diagram Hertzsprung-Russell diagram, a graph that shows the relationship between a star's surface temperature and absolute magnitude</p>	<p>main sequence the location on the H-R diagram where most stars lie; it has a diagonal pattern from the lower right (low temperature and luminosity) to the upper left (high temperature and luminosity)</p> <p>supernova a gigantic explosion in which a massive star collapses and throws its outer layers into space</p>
--	---

1. **List** What are the stages in the life cycle of an average star?

2. **Label** Label the axes on this H-R diagram.

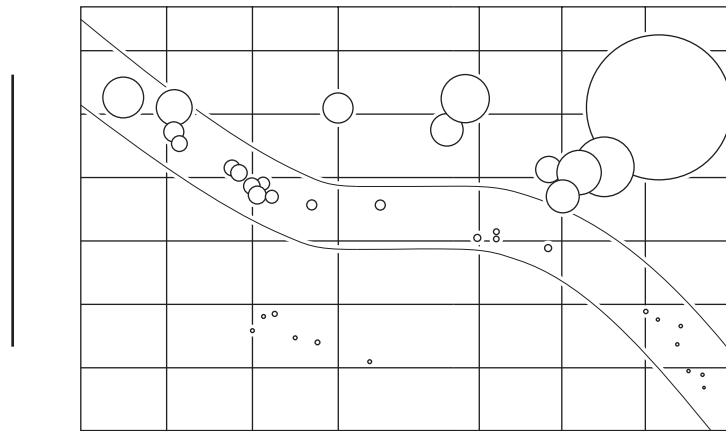

3. **Explain** How does a star's temperature change as the star ages from a main sequence star to a red giant and from a red giant to a white dwarf?

4. **Compare** How does the life cycle of a massive star differ from the life cycle of an average star?

SECTION 3 **Galaxies**



8.4.a, 8.4.b

BEFORE YOU READ

After you read this section, you should be able to answer these questions:

- What are different shapes that a galaxy can have?
- What are galaxies made of?
- How do galaxies form?

STUDY TIP

Organize As you read, make a table that compares the different types of galaxies.

READING CHECK

1. Explain How do scientists find out how many stars a galaxy is likely to have?

What Is a Galaxy?

If you look out on a clear night far from city lights, you can see hundreds of stars. Some of these stars are part of our galaxy called the Milky Way. Our galaxy actually has many more stars than you could ever see.

A **galaxy** is a large group of gas, dust, and millions of stars. The biggest galaxies contain more than a trillion stars. Scientists can't actually count the stars, of course. They estimate how many stars the galaxy has by measuring the size and brightness of the galaxy. The bigger and brighter the galaxy, the more stars it has. ✓

Galaxies come in different shapes and sizes. Scientists classify them according to their shapes. The most common types of galaxies are spiral, elliptical, and irregular.

SPIRAL GALAXIES

A spiral galaxy has two parts: a central bulge and arms that form a spiral around the center. The bulge is a dense group of old stars. The arms are made of gas, dust, and much younger stars.

The Milky Way is a spiral galaxy. Our sun is one of the 200 billion stars in the Milky Way. From Earth, the edge of the Milky Way looks like a bright belt of stars that stretches across the night sky.

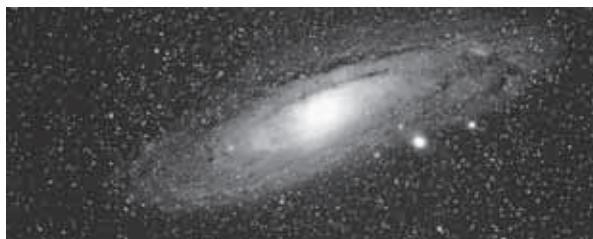

The Andromeda galaxy is a spiral galaxy. Our galaxy, the Milky Way, probably looks very much like Andromeda.

TAKE A LOOK

2. Identify In which part of this galaxy are the oldest stars located?

SECTION 3 Galaxies *continued*

ELLIPTICAL GALAXIES

An elliptical galaxy is made of many stars and looks like a snowball. Elliptical galaxies are among the largest galaxies in the universe, and some have up to 5 trillion stars! Scientists think that elliptical galaxies stopped making new stars more than 10 billion years ago.



Galaxy M87, an elliptical galaxy, has no spiral arms.

IRREGULAR GALAXIES

An irregular galaxy has no clear shape. It may have as few as 10 million stars, or it may have as many as several billion stars. Sometimes an irregular galaxy is formed when two galaxies collide.



The Large Magellanic Cloud, an irregular galaxy, is close to our own.

WHAT GALAXIES ARE MADE OF

Galaxies are made of gas, dust, and billions of stars. Some of these stars form different features. When scientists study the stars in galaxies, they look for these features: nebulae, open clusters, and globular clusters. ✓

	CALIFORNIA STANDARDS CHECK
<p>8.4.a Students know galaxies are clusters of billions of stars and may have different shapes.</p>	
<p>3. Compare Name two ways that spiral galaxies differ from elliptical galaxies.</p>	
<hr/>	
<hr/>	
<hr/>	
<hr/>	
<hr/>	
<hr/>	

	READING CHECK
<p>4. Identify What are galaxies made of?</p>	
<hr/>	
<hr/>	
<hr/>	

SECTION 3 Galaxies *continued*

NEBULAS

A **nebula** is a large cloud of gas and dust. Most stars are born in *nebulae* (or *nebulae*). Nebulas can be found throughout a galaxy, but they can be hard to see. Although some nebulas glow or reflect starlight, others absorb light and so are too dark to see. ✓

READING CHECK

5. Explain Why are some nebulas hard to see?



This is part of a nebula. The tall, thin shape to the left of the bright star is wider than our solar system.

OPEN CLUSTERS

An *open cluster* is a group of 100 to 1,000 stars. The stars in an open cluster are closer together than the rest of the stars in space. Open clusters are usually found along the body of a spiral galaxy. All of the stars were born at the same time from the same nebula. Newly formed open clusters have many bright blue stars.

Critical Thinking

6. Compare How is a nebula different from a star cluster?



We can see the open cluster Pleiades without a telescope.

GLOBULAR CLUSTERS

A *globular cluster* is a group of up to 1 million stars that are packed closely together. A globular cluster looks like a ball. Some globular clusters orbit spiral galaxies like the Milky Way. Others can be found near giant elliptical galaxies. All of the stars in a globular cluster were born at the same time from the same nebula.

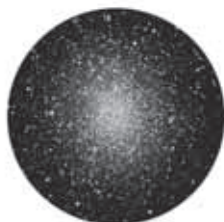

Omega Centauri is the largest globular cluster in the Milky Way galaxy. It has 5 million to 10 million stars.

Section 3 Review

8.4.a, 8.4.b



SECTION VOCABULARY

galaxy a collection of stars, dust, and gas bound together by gravity

nebula a large cloud of gas and dust in interstellar space; a region in space where stars are born

1. Compare How does a nebula differ from a galaxy?

2. List What three shapes can galaxies be?

3. Organize Complete the chart below to describe different features of galaxies.

Galaxy feature	What they are made of	Where they are found	Other characteristics
		throughout a galaxy	
	100 to 1,000 stars, relatively close together		It may have bright blue stars.
Globular cluster		around a spiral galaxy or near a large elliptical galaxy	

4. Apply Ideas Why do you think new stars form in the arms of a spiral galaxy and not in the central bulge?

5. Illustrate In the space below, make a sketch of what the Milky Way might look like from another galaxy.

SECTION 4 **Formation of the Universe**



8.4.a, 8.4.b

BEFORE YOU READ

After you read this section, you should be able to answer these questions:

- What is the big bang theory?
- How is the universe structured?
- How old is the universe?

STUDY TIP

Predict Before you read this section, write down your prediction of how scientists think the universe formed and what will happen to it in the future. As you read, take notes on these topics.

READING CHECK

1. Complete Scientists took careful measurements of galaxies and found that the universe is

How Do Scientists Think the Universe Formed?

The study of how the universe started, what it is made of, and how it changes is called *cosmology*. Like all scientific theories, theories about the beginning and end of the universe must be tested by observations or experiments.

To understand how the universe formed, scientists study the movement of galaxies. Careful measurements have shown that most galaxies are moving away from each other. This means that the universe is expanding. Knowing that the universe is expanding, scientists worked backward in time to figure out how the universe might have started. ✓

If the expanding universe could be watched in reverse, like a video on rewind, the universe would seem to contract. Eventually all matter would be squeezed into one small space. Now imagine running that same video forward. All the matter and energy in the universe would explode and begin to expand in all directions. This idea is known as the *big bang theory*.

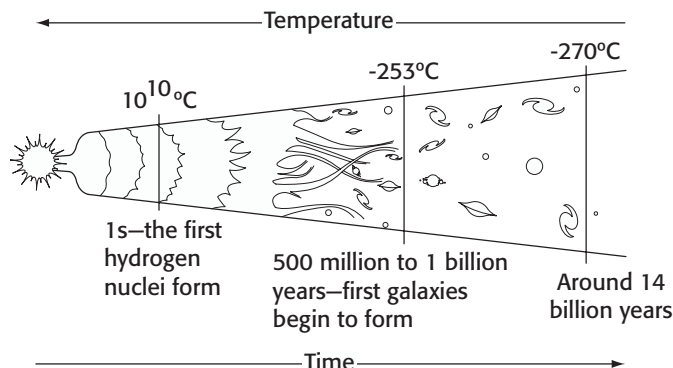

TAKE A LOOK

2. Identify After the big bang, how did the temperature of the universe change?

Most astronomers think that the big bang caused the universe to expand in all directions.

SECTION 4 Formation of the Universe *continued*

What Is the Big Bang Theory?

The theory that the universe began with a huge explosion is called the **big bang theory**. It is the model that explains why the universe is expanding. According to the theory, all the contents of the universe were squeezed into one very small volume. These contents were under extremely high pressure and temperature. About 14 billion years ago, this small volume rapidly expanded and cooled. ✓

Just minutes after the big bang, the following things had already been created:

- the light elements, such as helium
- the forces of nature, such as gravity
- the beginnings of galaxies

EVIDENCE SCIENTISTS HAVE FOR THE BIG BANG

All scientific theories must have evidence to support them. The first piece of evidence for the big bang theory was the expansion of the universe. The second piece of evidence is called *cosmic background radiation*.

Scientists use radio telescopes to pick up radiation with long wavelengths. Several decades ago, some scientists noticed a background “noise” coming from all directions in space. They believe this cosmic background radiation is energy left over from the original explosion. ✓

How Is the Universe Structured?

The universe contains many different objects. These objects are not just scattered around the universe. They are grouped into systems. Every object in the universe is part of a larger system:

- A planet is part of a planetary system.
- A planetary system is part of a galaxy.
- A galaxy is part of a galaxy cluster.

Earth is part of the planetary system called the solar system. Our solar system is part of the Milky Way galaxy.

 **READING CHECK**

3. Identify Where were the contents of the universe before the big bang?

 **READING CHECK**

4. List Give two pieces of evidence for the big bang theory.

Critical Thinking

5. Apply Concepts Do you think there are more planets or more galaxies in the universe? Explain your answer.

SECTION 4 Formation of the Universe *continued*

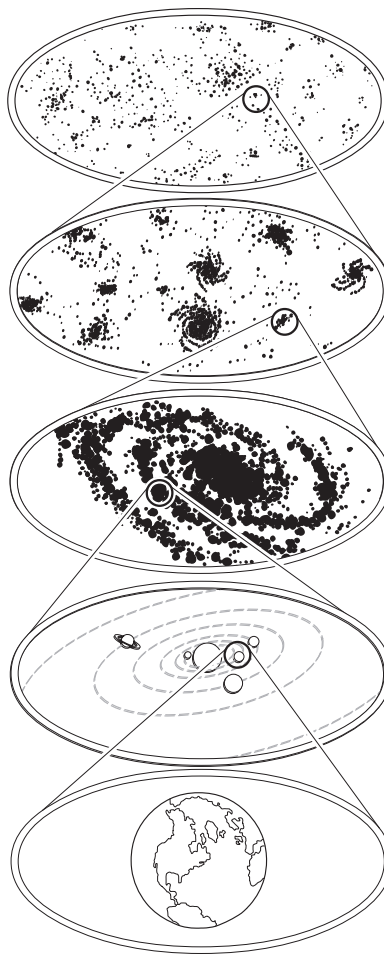

TAKE A LOOK

6. Label On the figure, label the systems that make up the structure of the universe.

How Old Is the Universe?

Scientists can estimate the age of the universe by studying the oldest stars in the Milky Way galaxy. These stars are white dwarfs. The first stars that formed after the big bang became white dwarfs after about 1 billion years. The oldest white dwarfs are between 12 billion and 13 billion years old. Scientists think that the universe must be about 14 billion years old. ✓

READING CHECK

7. Identify How old do scientists think the universe is?

No one knows what will happen to the universe in the future. Some scientists think that the universe will continue to expand faster and faster. Stars will age and die, and one day, the universe will become cold and dark. Even after the universe becomes cold and dark, it will continue to expand.

Section 4 Review

8.4.a, 8.4.b



SECTION VOCABULARY

big bang theory the theory that all matter and energy in the universe was compressed into an extremely small volume that 13 billion to 15 billion years ago exploded and began expanding in all directions

1. Explain How does the expansion of the universe support the big bang theory?

2. Define What is cosmic background radiation?

3. Describe Describe the structure of the universe.

4. Explain Imagine you are a scientist studying the formation of the universe. Explain how you would estimate the age of the universe.

5. Explain What will happen to the universe if it expands forever?

SECTION 1 **A Solar System Is Born**



8.2.g, 8.4.b, 8.4.c, 8.4.d

BEFORE YOU READ

After you read this section, you should be able to answer these questions:

- How did the solar system form?
- How do the sun and other stars produce energy?
- How do astronomers measure large distances?

STUDY TIP

Organize In your notebook, make a concept map by using the terms *gravity*, *pressure*, *nebula*, *solar nebula*, *sun*, and *planets*.

READING CHECK

1. **Identify** What is a nebula?

READING CHECK

2. **Explain** Why is the force of gravity in a nebula very weak?

How Does a Solar Nebula Stay Together?

At the center of our solar system is a star that we call the sun. Nine planets and other smaller objects move around the sun. Most planets have one or more moons that move around them.

The ingredients for building solar systems, such as ours, are in areas that seem to be empty space. Just as there are clouds in the sky, there are clouds in space. These clouds are called nebulae. A **nebula** is a mixture of gases and dust. The gases are mostly hydrogen and helium, and the dust is made of other elements, such as carbon and iron. ✓

GRAVITY

The gas and dust of nebulae are made of matter. The force of gravity holds matter together. In a nebula, the force of gravity is weak because the particles are small and far apart. Nebulae are less dense than the air around you. The force of gravity is just enough to keep atoms and molecules in the nebula from moving apart. ✓

The figure below represents a close-up view of a nebula. Notice that the particles are far apart so there is little gravitational attraction between them. The particles are also moving slowly so the nebula is cold.

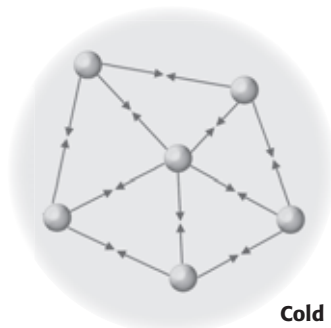

Gravity causes the particles in a nebula to be attracted to each other.

SECTION 1 A Solar System Is Born *continued*

PRESSURE

Because gravity pulls particles together, you might expect that it would cause the nebula to collapse. However, this doesn't happen, because there is another force that works against gravity. That force is pressure. The particles in the nebula are in constant motion and they crash into one another. These collisions cause pressure. ✓

As particles move faster, pressure and temperature increase. In a nebula, outward pressure balances the pull of gravity and keeps the nebula from collapsing.

The figure below shows how the particles within a nebula behave as the pressure increases and also when pressure and gravity are balanced.

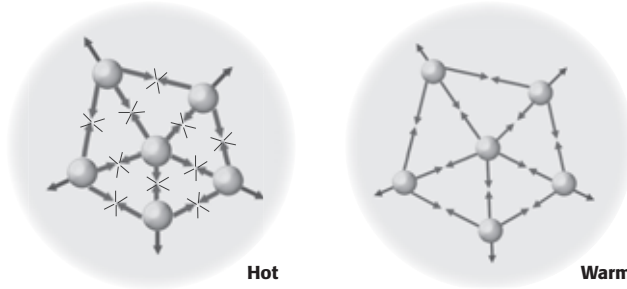

As particles move closer together, collisions cause pressure to increase and particles are pushed apart.

If the inward force of gravity is balanced by outward pressure, the nebula becomes stable.

What Happens When Gravity and Pressure Become Unbalanced?

The balance between gravity and pressure can be upset if two nebulas collide. It can also be upset if a nearby star explodes. These events compress, or push together, small regions of the nebula. As these regions come together, gravity pulls them into a tight mass.

As the mass tightens, particles in the mass move faster, and the temperature increases. The stage is set for a star to form. The **solar nebula**, the cloud of gas and dust that became our solar system, may have formed this way. ✓

How Did the Solar System Form?

On the next page you will see the events that could have occurred during the change from the solar nebula to the solar system. As the solar nebula collapsed, it began to rotate. The center of the rotating cloud became hotter and denser. The gas and dust around the center formed a disk that began to cool and form bigger particles. The pull of gravity caused the particles to come together and form even larger particles.

READING CHECK

3. Identify What is the cause of the pressure that works against gravity in a nebula?

Critical Thinking

4. Evaluate Models In the figure on the right, the particles appear to be stationary. How do you know that they are actually in motion?

READING CHECK

5. Identify What is the solar nebula?

Critical Thinking

6. Identify Which affects a nebular collapse more: gravity or pressure?

SECTION 1 A Solar System Is Born *continued*

The Formation of the Solar System

TAKE A LOOK

7. Describe In which part of the solar nebula is matter more densely packed, the edges or the center?

TAKE A LOOK

8. Identify What causes planetesimals to stay together, forming planets, when they collide?

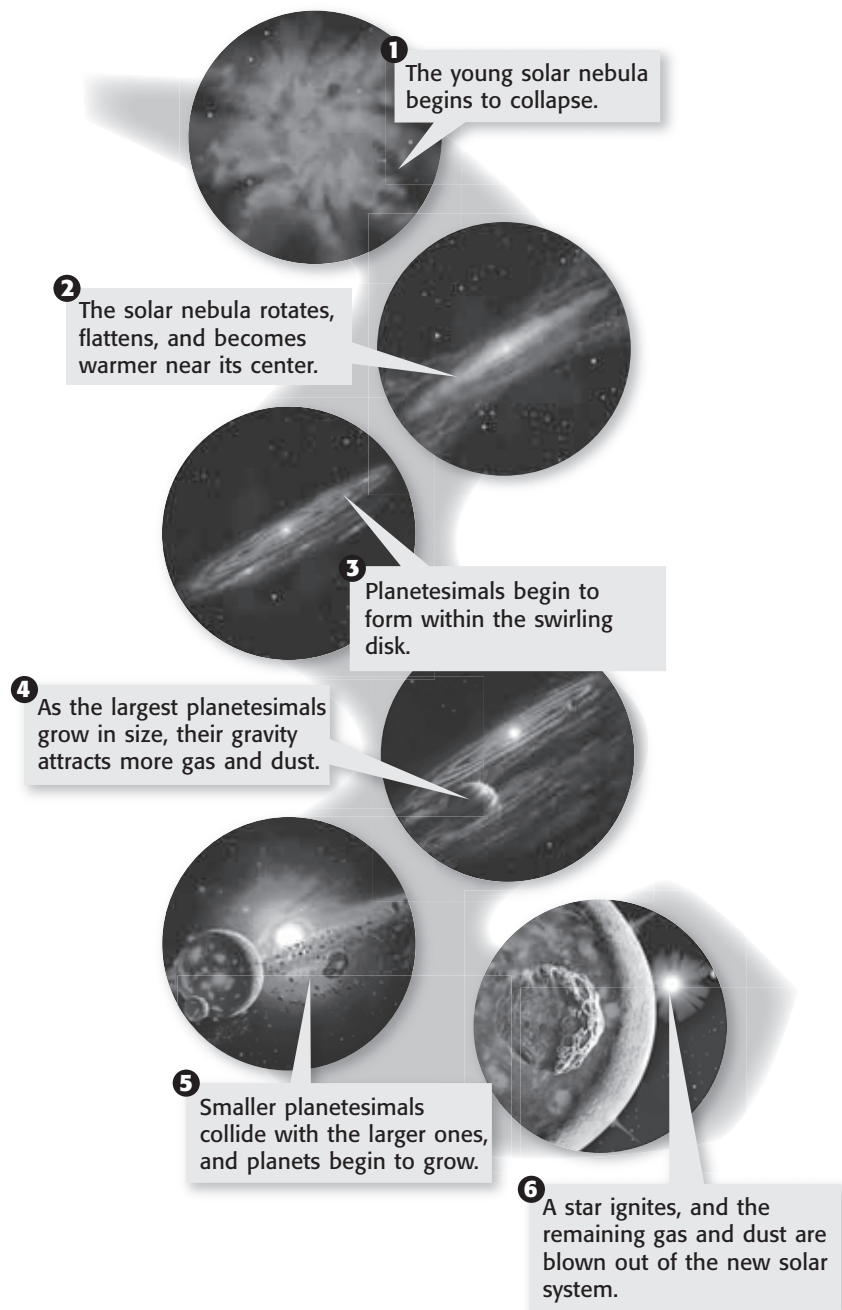

SECTION 1 A Solar System Is Born *continued*

PLANETESIMALS AND PLANETS

As the particles collided and grew, they formed planetesimals, bodies the size of boulders and asteroids. As they grew, the gravity of these planetesimals pulled more and more matter toward them. Eventually, they grew large enough to become planets and moons. The sun, the planets, and the moons are mostly spherical. That is because gravity pulls equally in all directions from the center. ✓

THE BIRTH OF A STAR

As the planets were forming, gravity pulled matter to the center of the nebula. The center became so hot and dense that hydrogen atoms began to fuse, or join together, to form helium atoms. The energy released by fusion pushed outward and balanced the pull of gravity. The gas stopped collapsing and the sun was born. ✓

The diameter of the sun is more than 100 times the diameter of Earth. At the sun's surface, its temperature is about 5,500°C. The core of the sun, where energy is generated, is much hotter than that. The figure below shows the structure of the sun and the layers below its surface.

The Structure and Atmosphere of the Sun

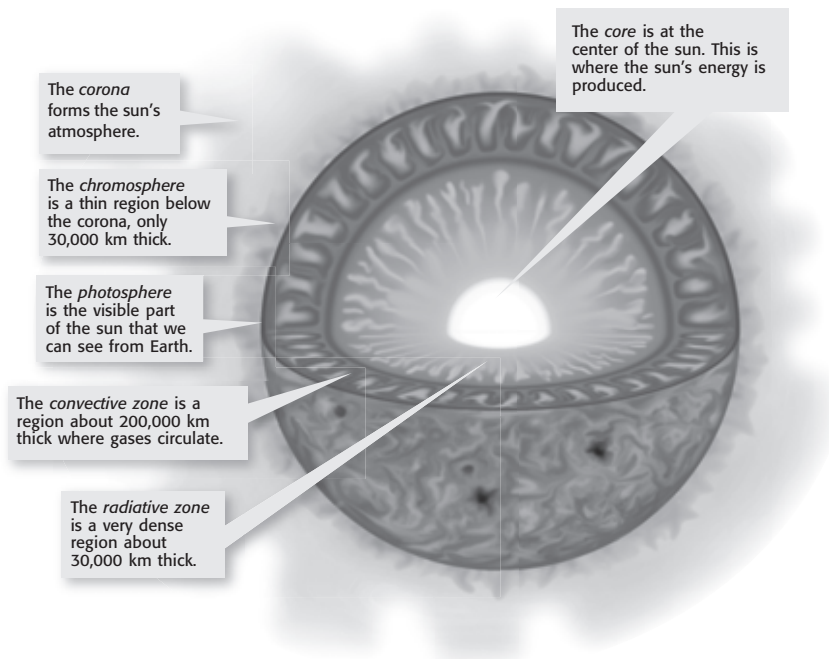

READING CHECK

9. Identify What is the shape of dense bodies the size of planets or larger?

READING CHECK

10. Define What does the word *fuse* mean?

TAKE A LOOK

11. List Place the following parts of the sun in order from the center outwards: chromosphere, core, corona, radiative zone.

SECTION 1 A Solar System Is Born *continued*

Math Focus

12. Represent Quantities
 The speed of light, c , in the equation $E = mc^2$, is equal to 300,000,000 m/s or 3.0×10^8 m/s. Using scientific notation, what is the value of c^2 ? Include units.

How Does the Sun Produce Energy?

The sun has been producing energy and shining on Earth for about 4.6 billion years. How could it stay hot for such a long time?

The answer to that question came early in the 20th century. Albert Einstein figured out that energy and matter can be changed into each other. Einstein's famous formula is $E = mc^2$, in which E is energy, m is mass, and c is the speed of light. Because the speed of light is a very large number, this equation states that a tiny amount of matter can be changed into a lot of energy. This explains the large amount of energy produced by the sun.

NUCLEAR FUSION

Scientists now know that the sun's energy comes from *nuclear fusion*. Nuclear fusion is the process in which two or more low-mass nuclei join together to form a larger nucleus. When nuclei fuse, energy is released. Stars begin to generate energy when hydrogen nuclei fuse to form helium. There is a balance between the extremely high pressure from this energy and gravity due to the star's mass. This balance, shown in the figure below, gives a star its spherical shape.

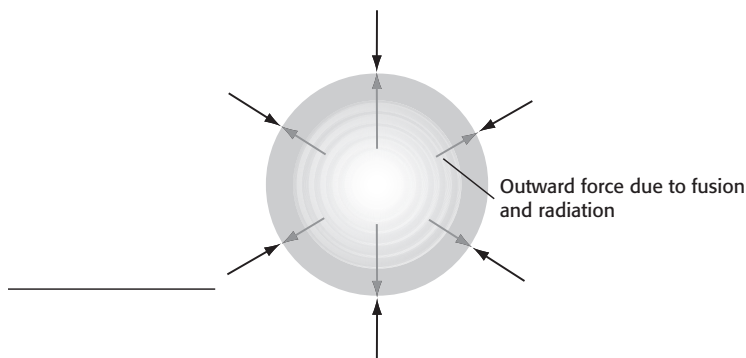

TAKE A LOOK

13. Identify Label the force indicated by the arrows.

READING CHECK

14. Identify What element is formed when hydrogen nuclei fuse together?

CONDITIONS THAT CAUSE FUSION

Under normal conditions, two hydrogen nuclei cannot get close enough to one another to fuse. That is because they each have a positive electric charge. Like charges repel one another, just as like poles on a magnet repel one another. However, in the center of the sun and other stars, the temperature and pressure are extremely high.

The high pressure and rapid motion of particles are enough to overcome the force of repulsion. Hydrogen nuclei are forced together, and the hydrogen fuses into a different element, helium.

SECTION 1 A Solar System Is Born *continued*

What Happens During Fusion in the Sun?

There are three steps in the fusion of hydrogen in the sun, as shown in the figure below.

Step 1: Two hydrogen nuclei, also called protons, collide and fuse. This process emits particles and energy, and one of the protons becomes a neutron. The proton and neutron combine to form deuterium, a heavy form of hydrogen.

Step 2: Another proton combines with the deuterium nucleus (one proton and one neutron). This forms a nucleus with two protons and one neutron, known as helium-3. This process also releases energy.

Step 3: Two helium-3 nuclei collide and fuse. As this happens, two protons are released. The remaining two protons and two neutrons combine to form a nucleus of helium-4, usually just called a helium nucleus. The mass of the helium nucleus is a tiny amount smaller than the mass of the original protons. This very small amount of mass has been converted into a large amount of energy

Critical Thinking

15. Identify How do you know that deuterium is a form of hydrogen, not a form of helium?

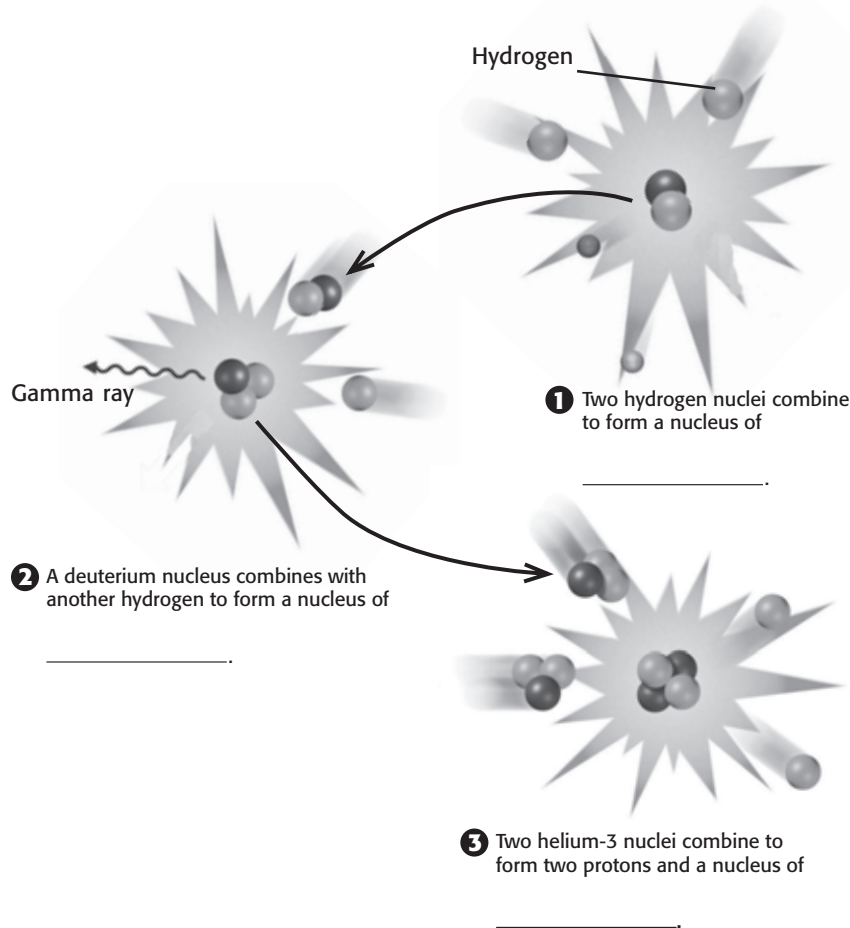

TAKE A LOOK

16. Fill In Label the three nuclei shown in the illustration.

SECTION 1 A Solar System Is Born *continued*

How Are Distances Between Planets Measured?

One way that scientists measure distances in space is by using an astronomical unit. One **astronomical unit** (AU) is the average distance between the sun and Earth. This distance is about 150 million km. This unit is normally used to refer to distances within the solar system. For example, the average distance from the sun to Pluto is about 39.5 AU. So, Pluto is 39.5×150 million km = 5,900 million km from the sun.

Another way to measure distances in space is by using the speed of light. Light travels at about 300,000 km/s in space. In one minute, light travels about 18 million km. Light from the sun takes 8.3 minutes to reach Earth.

It takes light over 4 years to reach Earth from the nearest star (other than our sun). That is why distances to stars are measured in *light-years*. Light travels about 9.5×10^{12} km or 9,500,000,000,000 km in one year. A light-year is about 63,000 times farther from Earth as our sun is.

 **CALIFORNIA STANDARDS CHECK**

8.4.c Know how to use astronomical units and light years as measures of distance between the Sun, stars, and Earth.

17. Analyze Ideas If an asteroid is found to be 300 million km from Earth, how many astronomical units is this?

How Is the Solar System Divided?

Astronomers divide the solar system into two main parts, as shown in the figure below. These parts are called the *inner solar system* and the *outer solar system*. The inner solar system contains the four planets that are closest to the sun—Mercury, Venus, Earth, and Mars.

Jupiter is the first planet in the outer solar system. The distance between Mars and Jupiter is much larger than the distance between Earth and Mars. The outer solar system contains five planets—Jupiter, Saturn, Uranus, Neptune, and Pluto.

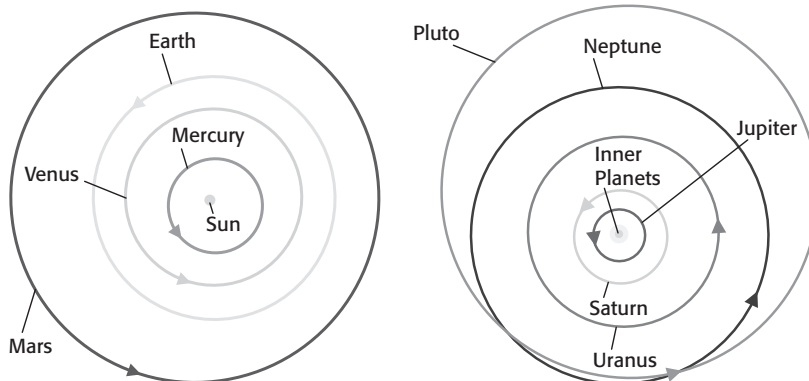

TAKE A LOOK

18. Identify Pluto is listed as the most distant planet from the sun because it has the greatest average distance. What planet is sometimes farther from the sun than Pluto?

The planets of the inner solar system and their orbits are shown on the left. The planets of the outer solar system and their orbits are shown on the right.

Section 1 Review

8.2.g, 8.4.b, 8.4.c, 8.4.d



SECTION VOCABULARY

<p>astronomical unit the average distance between the Earth and the sun; approximately 150 million kilometers (symbol, AU)</p>	<p>nebula a large cloud of gas and dust in interstellar space; a region in space where stars are born or where stars explode at the end of their lives</p> <p>solar nebula the cloud of gas and dust that formed our solar system</p>
---	---

1. Identify What are the two forces acting on the particles inside a nebula that affect its balance? How do they affect particles?

2. Classify Fill in the blanks to complete the table.

Layer of the sun	Description
Core	
	very dense region surrounding the core, about 300,000 km thick
Convective zone	
	the part of the sun that we can see from Earth
	thin region below the corona, about 30,000 km thick
Corona	

3. Apply Concepts Why are all the large bodies in the solar system, the sun and the planets, shaped like spheres?

4. Identify What unit is used to measure distances in our solar system? How large is this unit?

5. Identify What unit is used to measure distances to stars? How large is this unit?

CHAPTER 16 Our Solar System

SECTION 2 The Inner Planets



California Science Standards

8.4.c, 8.4.e

BEFORE YOU READ

After you read this section, you should be able to answer these questions:

- Which planets are known as the inner planets?
- What properties do the inner planets share?

STUDY TIP

Organize In your notebook, create a chart showing the similarities and differences among the inner planets.

READING CHECK

1. Explain Why are the inner planets called terrestrial planets?

READING CHECK

2. Explain Why did the atmosphere of Mercury boil away, while the other planets kept at least some of their original atmospheres?

Critical Thinking

3. Infer Which of the facts on the table can scientists use to infer that Mercury has a core made of iron?

Why Group the Inner Planets Together?

The inner solar system includes the only planet known to support life, Earth, and three other planets. These four inner planets are called **terrestrial planets** because they all have a makeup similar to that of Earth. The terrestrial planets are much smaller, denser, and more rocky than the outer planets. ✓

Which Planet Is Closest to the Sun?

Mercury is the planet closest to the sun. After Earth, it is the second densest object in the solar system. This is because, like Earth, Mercury has a large iron core in its center. The surface of Mercury is covered with craters.

The atmosphere of Mercury is very thin. Almost all of the gases that once made up its atmosphere have boiled off into space. This happened because it is so close to the sun. ✓

The amount of time that an object takes to rotate once is called the object's *period of rotation*. It is the length of a day on a planet. Mercury rotates on its axis much more slowly than Earth. Its day is about 59 Earth days long.

On Mercury, a year is not much longer than a day. Each planet revolves around the sun at a particular rate. The amount of time needed to go around the sun once is called the planet's *period of revolution*. It's the length of one year on the planet. A year on Mercury is equal to 88 Earth days. So each Mercurian year is only 1.5 Mercurian days long.

Mercury Statistics

Distance from sun	0.38 AU
Period of rotation	58 days, 19 h
Period of revolution	88 days
Diameter	4,879 km
Density	5.43 g/cm ³
Surface gravity	38% of Earth's

SECTION 2 The Inner Planets *continued***Is Venus Earth's Twin?**

The second planet from the sun is Venus. In some ways, Venus is more like Earth than any of the other planets. Venus is just slightly smaller, less dense, and less massive than Earth. In other ways, the planets are quite different.

If you could observe the sun from the surface of Venus, you would see it rise in the west and set in the east. That is because Venus and Earth rotate on their axes in opposite directions. The rotation of Earth is called **prograde rotation**. This means it spins in a counterclockwise direction if viewed from above its North Pole. When observed the same way, Venus spins clockwise, which is called **retrograde rotation**. ✓

THE ATMOSPHERE OF VENUS

Venus has the densest atmosphere of the terrestrial planets. On its surface, the atmospheric pressure of Venus is 90 times that of Earth's atmosphere. This pressure would instantly crush a human on Venus. The atmosphere is mostly made of carbon dioxide and thick clouds made of sulfuric acid. The thick atmosphere holds heat well, so the surface temperature on Venus averages 464°C, hot enough to melt lead and some other metals.

Venus Statistics

Distance from sun	0.72 AU
Period of rotation	243 days, 16 h
Period of revolution	224 days, 17 h
Diameter	12,104 km
Density	5.24 g/cm ³
Surface gravity	91% of Earth's

MAPPING THE SURFACE OF VENUS

The atmosphere of Venus reflects sunlight so well that Venus is sometimes the brightest object in the sky. Only the sun and moon are brighter.

Because of its thick atmosphere, the surface of Venus cannot be observed from Earth through telescopes. Between 1990 and 1992, the *Magellan* spacecraft made maps of Venus using radar waves. The waves can travel through the atmosphere and bounce off the surface. Maps made from the radar data showed that Venus has craters, mountains, lava plains, and volcanoes.

 **READING CHECK**

4. Compare How do prograde rotation and retrograde rotation differ?

TAKE A LOOK

5. Compare How does the length of a day on Venus compare with the length of its year?

Critical Thinking

6. Analyze Methods Why would scientists use *Magellan's* radar instead of telescopes to map the surface of Venus?

SECTION 2 The Inner Planets *continued*

Where Do We Find Life?

Until the 20th century, no one could know what Earth looked like from space. We can now look at a sparkling blue planet. The blue color comes from light reflected from the water of the oceans that cover much of Earth's surface. ✓

READING CHECK

7. Identify What feature of Earth causes it to appear blue from space?

Math Focus

8. Calculate Use the information on the table to explain why every fourth year is a leap year. Show your work.

A CONSTANTLY CHANGING PLANET

As far as we know, Earth is the only planet in the solar system that has the combination of factors needed to support life. These factors include abundant water and just the right amount of energy from the sun.

Earth is always changing. Landmasses are in slow, but constant, motion. These motions, along with weathering by wind and water, constantly reshape the surface of Earth.

Earth Statistics

Distance from sun	1.0 AU
Period of rotation	23 h, 56 min
Period of revolution	365 days, 6 h
Diameter	12,756 km
Density	5.52 g/cm ³
Surface gravity	100% of Earth's

STUDYING EARTH FROM SPACE

NASA's Earth Science Enterprise is a program to study Earth from space. Studying Earth from space lets scientists learn about Earth as a whole system. It helps them understand changes in Earth's atmosphere, oceans, ice, landforms, and living things. The study gives clues about how human activities affect everything on Earth.

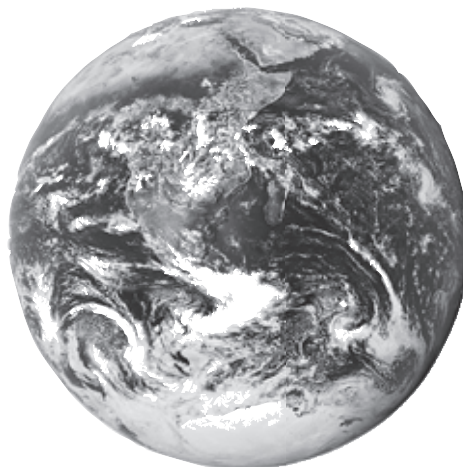

This image of Earth was taken on December 7, 1972, by members of the crew of *Apollo 17* on their way to the moon.

SECTION 2 The Inner Planets *continued***What Is the Red Planet?**

Besides Earth, the most studied planet in the solar system is Mars. Mars has a red color and is known as the Red Planet. Many people believe that there could be life on Mars.

Scientists have learned much about Mars by observing it from Earth. However, most of our knowledge of the planet has come from unmanned spacecraft. So far, these observations have found no evidence of life.

THE ATMOSPHERE OF MARS

Because it has a thinner atmosphere than Earth and is farther from the sun, Mars is colder than Earth. In the middle of the summer, the spacecraft *Mars Pathfinder* recorded a temperature range from -13°C to -77°C . The Martian atmosphere is carbon dioxide.

The atmospheric pressure on Mars is very low. At the surface, it is about the same as the pressure 30 km above the surface of Earth. Because of low temperature and air pressure, liquid water cannot exist on the surface of Mars.

Mars Statistics

Distance from sun	1.52 AU
Period of rotation	24 h, 37 min
Period of revolution	687 days
Diameter	6,794 km
Density	3.93 g/cm^3
Surface gravity	38% of Earth's

WATER ON MARS

Even though water cannot exist on the surface of Mars today, it may have in the past. Evidence from spacecraft and surface studies of Mars suggests that some of its features were made by liquid water.

There are many places where surface features are similar to those caused by water erosion on Earth. Other features suggest the presence of sediments that may have been deposited by the water from a large lake.

Scientists cannot prove that these features were caused by liquid water. However, they indicate that at some time in the past, Mars may have had liquid water. If this is true, it would show that Mars was once warmer and had a thicker atmosphere than it does today.

**CALIFORNIA STANDARDS CHECK**

8.4.e Students know the appearance, general composition, relative position and size, and motion of objects in the solar system, including planets, planetary satellites, comets, and asteroids.

9. Identify What are two reasons that the surface of Mars is colder than that of Earth?

TAKE A LOOK

10. Compare How does the length of a day on Mars compare with the length of day on Earth?

**READING CHECK**

11. Identify What two Martian features suggest that water once existed on its surface?

SECTION 2 The Inner Planets *continued***THE WATER NOW**

Mars has two polar icecaps that are made of a combination of frozen water and frozen carbon dioxide. Most of the water on Mars is trapped in this ice. There is some evidence from the *Mars Global Surveyor* that water could exist just beneath the surface. If so, it may be there in liquid form. If Mars does have liquid water beneath its surface, there is a possibility that life may exist on Mars. ✓

✓ **READING CHECK**

12. Identify Where does water exist on Mars today?

VOLCANOES ON MARS

There are the remains of giant volcanoes on the surface of Mars. They show that Mars has had active volcanoes in the past. Unlike Earth, however, the volcanoes are not spread across the whole planet. There are two large volcanic systems on Mars, one of which is about 8,000 km long.

The largest mountain in the solar system, Olympus Mons, is one of the Martian volcanoes. It is a shield volcano that is similar to Muana Kea on the island of Hawaii. However, Olympus Mons is nearly 24 km tall. That is three times as tall as Mount Everest! Its base is 600 km across. It may have grown so tall because the volcano erupted for long periods of time.

MISSIONS TO MARS

Several recent missions to Mars were launched to learn more about the Red Planet. The figure below shows *Mars Express Orbiter*, which reached Mars in December 2003. Since then, it has been investigating Mars from space, including searching for water. In January 2004, the exploration rovers *Spirit* and *Opportunity* landed on Mars. These solar-powered, wheeled robots have found evidence that water once existed on the Martian surface. ✓

✓ **READING CHECK**

13. Describe What evidence have the rovers *Spirit* and *Opportunity* found?



The *Mars Express Orbiter* helps scientists map Mars and study its atmosphere.

Section 2 Review

8.4.c, 8.4.e



SECTION VOCABULARY

prograde rotation the counterclockwise spin of a planet or moon as seen from above the planet's North Pole; rotation in the same direction as the sun's rotation.

Wordwise The prefix *pro-* means "forward."

retrograde rotation the clockwise spin of a planet or moon as seen from above the planet's North Pole

terrestrial planet one of the highly dense planets nearest to the sun: Mercury, Venus, Earth, and Mars

1. Compare How does retrograde rotation compare with the rotation of Earth?

2. Classify Fill in the blanks to complete the table.

Planet	Distance from sun	Period of rotation
	0.38 AU	58 days, 19 h
	0.72 AU	243 days, 16 h
	1.00 AU	365 days, 6 h
	1.52 AU	1 year, 322 days

3. Analyze Ideas Why do scientists think that Mars was once warmer and had a thicker atmosphere than it does today?

4. Identify Relationships How is the surface gravity of the terrestrial planets related to the type of atmosphere that they have? (Hint: Examine the statistics tables.)

5. Identify Relationships The diameter of Venus is almost the same as Earth's, and its surface gravity is less. Why is gravity lower on Venus than on Earth? (Hint: Examine the statistics tables for both planets.)

SECTION 3 **The Outer Planets**



8.4.c, 8.4.e

BEFORE YOU READ

After you read this section, you should be able to answer these questions:

- How are Jupiter, Saturn, Uranus, and Neptune similar?
- How does Pluto differ from the other planets?



Organize In your notebook, create a chart showing the similarities and differences among the outer planets.

Why Group the Outer Planets Together?

The outer planets are very different from the inner planets. Except for Pluto, the outer planets are made mostly of gas or rock. These planets are called **gas giants**, because they have massive gas atmospheres.

Which Planet Is the Biggest?

Jupiter, shown in the figure below, is the largest planet in our solar system. Its mass is twice as large as the other eight planets combined. Jupiter is made mostly of hydrogen. As large as it is, Jupiter’s rotation takes less than 10 hours.

The atmosphere of Jupiter consists of hydrogen, helium, and small amounts of ammonia, methane, and water. Huge storms blow in the atmosphere with winds of up to 540 km/h. Its largest feature, the Great Red Spot, is thought to be a storm three times the size of Earth. The core of Jupiter is very hot, with temperatures reaching 30,000°C. So, it radiates more energy than it receives from the sun.

Jupiter Statistics

Distance from sun	5.20 AU
Period of rotation	9 h, 55.5 min
Period of revolution	11 Earth years, 313 days
Diameter	142,984 km
Density	1.33 g/cm ³
Surface gravity	236% of Earth’s

TAKE A LOOK

1. Identify Which of the facts on the table can you use to infer that Jupiter has a shorter day than Earth does?



This *Voyager 2* image of Jupiter was taken at a distance of 28.4 million km. Io, one of Jupiter’s moons, can be seen in the lower right-hand side of the photograph.

SECTION 3 The Outer Planets *continued*

What Are Saturn’s Rings?

Saturn is the second-largest planet in the solar system. Saturn’s volume is 764 times as much as Earth’s, but its mass is only 96 times Earth’s mass. That is because Saturn is the least dense of all the planets. Like Jupiter, Saturn is made up mostly of hydrogen with some helium and traces of other gases and water.

Saturn Statistics

Distance from sun	9.54 AU
Period of rotation	10 h, 42 min
Period of revolution	29 Earth years, 155 days
Diameter	120,536 km
Density	0.69 g/cm ³
Surface gravity	92% of Earth’s

Saturn is best known for the rings that orbit the planet above its equator. They are about 250,000 km across (greater than the distance from Earth to the moon) but less than 1 km thick. The rings are made of trillions of particles of water ice and dust. These particles range from a centimeter to several kilometers across. ✓

Astronomers are still debating the mystery of where Saturn’s rings came from. One idea is that the rings are pieces of a large comet that came too close to Saturn. The pull of the planet’s gravity could tear a comet apart. Spacecraft have passed close to Saturn and sent information about its rings back to Earth.

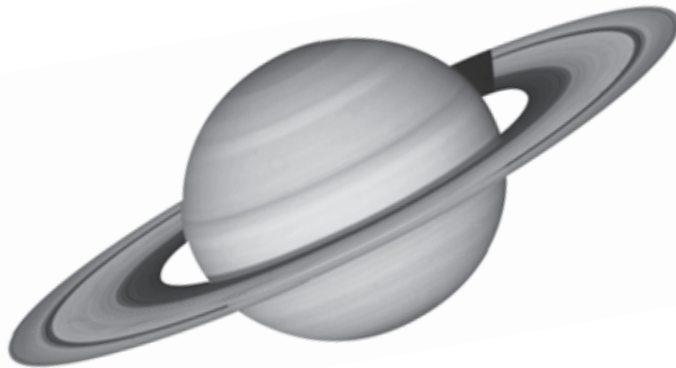

This *Voyager 2* image of Saturn was taken from 21 million km away.

Math Focus

2. Compare About how many times does Earth revolve around the sun while Saturn goes around the sun one time?

READING CHECK

3. Identify What materials make up the rings of Saturn?

Critical Thinking

4. Apply Concepts Even though Saturn has more mass than Earth, its surface gravity is less than that of Earth. Why is Saturn’s surface gravity less than Earth’s?

SECTION 3 The Outer Planets *continued*

What Lies Beyond Saturn?

Saturn is the most distant planet that was known before the telescope was invented. The next planet, Uranus, is the third largest planet in the solar system. It is so far from the sun that it does not reflect much light. It cannot be seen from Earth without using a telescope.

Like Jupiter and Saturn, Uranus is made mostly of hydrogen, helium, and small amounts of other gases. One of these other gases, methane, filters sunlight and gives the planet a greenish color. ✓

The rotation of Uranus is unusual. As shown in the figure below, the north and south poles of Uranus point almost directly at the sun. The north and south poles of most other planets, like Earth, are directed away from the sun.

For about half the Uranian year, one pole is constantly in sunlight, and for the other half of the year it is in darkness. Some scientists think that Uranus may have started out with the same kind of rotation as the other planets. It may have been tipped over by a collision with a massive object.

Uranus Statistics

Distance from sun	19.22 AU
Period of rotation	17 h, 12 min
Period of revolution	83 Earth years, 273 days
Diameter	51,118 km
Density	1.27 g/cm ³
Surface gravity	89% of Earth's

READING CHECK

5. Identify What is the main element in the gas giants?

TAKE A LOOK

6. Compare How does the length of a year on Uranus compare with the length of a year on Earth?

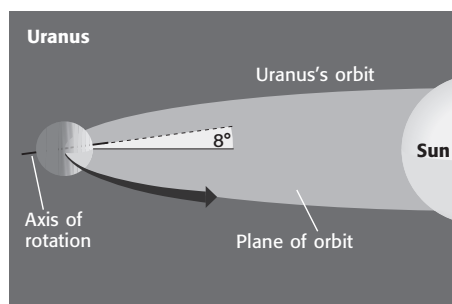

Uranus's axis of rotation is tilted so that the axis is nearly parallel to the plane of Uranus's orbit.

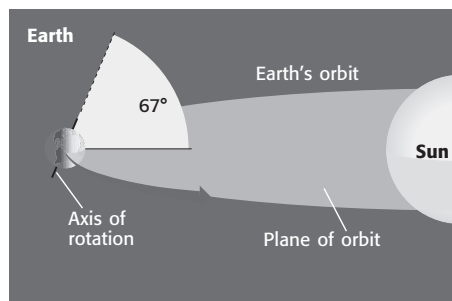

In contrast, the axes of most other planets are closer to perpendicular to their plane of orbit.

TAKE A LOOK

7. Define What two points on a planet's surface are used to define its axis of rotation?

SECTION 3 The Outer Planets *continued***Which Planet Is Next?**

Some astronomers predicted that there was a planet beyond Uranus before the planet was observed. Uranus did not move in its orbit exactly as they expected. The force of gravity due to another large object was affecting it. Using predictions of its effect on Uranus, astronomers discovered Neptune in 1846. ✓

Neptune is the fourth largest planet in the solar system. Like the other gas giants, Neptune is made up mostly of hydrogen, helium, and small amounts of other gases. It has a deep blue color, which is caused by methane in its atmosphere. Methane absorbs the red light so more blue light is reflected than red.

Clouds and weather changes are seen in the atmosphere of Neptune. The spacecraft *Voyager* flew past Neptune in 1989 and observed a Great Dark Spot in the southern hemisphere. This spot was a storm as large as Earth. It moved across the planet's surface at about 300 m/s. By 1994, the Great Dark Spot had disappeared. Another dark spot was then located in the northern hemisphere.

Neptune has the fastest winds of any planet in the solar system. Observations from spacecraft show that these winds move through the atmosphere at more than 1,000 km/h. No one knows what causes these winds.

Neptune Statistics

Distance from sun	30.06 AU
Period of rotation	16 h, 6 min
Period of revolution	163 Earth years, 263 days
Diameter	49,528 km
Density	1.64 g/cm ³
Surface gravity	112% of Earth's

Why Is Pluto Called the Mystery Planet?

Scientists thought the path of Neptune's orbit indicated another gas giant even farther from the sun. So, they looked for another planet. It turned out another gas giant could not be located. However, another planet was found. Pluto was discovered in 1930. Pluto's distance from the sun averages 5.9 billion miles, almost 40 times as far away as Earth.

 **READING CHECK**

8. Explain What evidence did astronomers have that Neptune existed before they actually observed it?

TAKE A LOOK

9. Compare How does Neptune's average distance from the sun compare with Earth's?

SECTION 3 The Outer Planets *continued*

TAKE A LOOK

10. Compare How does the length of a planet's year compare with its distance from the sun? Use the period of revolution on this table and on the tables of the other planets.

A SMALL WORLD

Unlike the other outer planets, Pluto is not a gas giant. In fact, it is the smallest planet in the solar system. Pluto is made of rock and ice and has a thin atmosphere composed of methane and nitrogen. Scientists do not know if Pluto was formed along with the other planets.

Pluto Statistics

Distance from sun	39.5 AU
Period of rotation	6 days, 10 h
Period of revolution	248 Earth years, 4 days
Diameter	2,390 km
Density	1.75 g/cm ³
Surface gravity	6% of Earth's

One of Pluto's moons, called Charon, is a little more than half the size of the planet. Because they are so distant, we know very little about Pluto and Charon. In some ways, Pluto and Charon act as a double planet.

In 2006, the spacecraft *New Horizons* began a 10-year trip to study Pluto and Charon. The figure below shows an artist's idea of the view from Pluto. The sun looks like a very bright star beyond Charon. The sun is so distant that the temperature on Pluto only reaches about -235°C .



An artist's view of the sun and Charon from Pluto shows how little light and heat Pluto receives from the sun.

BEYOND PLUTO

In recent years, scientists have discovered hundreds of objects in our solar system beyond Pluto. This region of the solar system, which is called the *Kuiper belt*, contains small bodies that are mostly made of water ice. Some of these objects are more than half the size of Pluto.

Some scientists argue that Pluto should not be considered a planet at all. Instead, they consider it an object in the Kuiper belt.

In October 2003, an object that may be the tenth planet was discovered in the Kuiper belt. Called 2003UB313, it is almost 16 billion km from the sun and is larger than Pluto. ✓

READING CHECK

11. Identify Where is the Kuiper belt located?

Section 3 Review

8.4.c, 8.4.e



SECTION VOCABULARY

gas giant a planet that has a deep, massive atmosphere, such as Jupiter, Saturn, Uranus, or Neptune

1. Identify What is the main element found in the atmosphere of a gas giant planet?

2. Classify Fill in the blanks to complete the table.

Planet	Distance from sun (AU)	Period of rotation
	5.20	11 Earth years, 313 days
	9.54	29 Earth years, 155 days
	19.21	83 Earth years, 273 days
	30.06	163 Earth years, 263 days
	39.5	248 Earth years, 4 days

3. Evaluate Data As planets get farther from the sun, what happens to the length of their year and their surface temperature?

4. Make Comparisons How do the gas giants differ from the inner planets of the solar system? In your answer, discuss composition, size, distance from the sun, length of a year, and how much energy they get.

5. Identify Relationships What properties of Pluto might make scientists think that it is a Kuiper belt object?

CHAPTER 16 Our Solar System
SECTION 4 **Moons**



8.2.g, 8.4.d, 8.4.e

BEFORE YOU READ

After you read this section, you should be able to answer these questions:

- How did Earth’s moon form?
- How does the moon appear as it revolves around Earth?
- What moons revolve around other planets?

STUDY TIP

Organize In your notebook, create a concept map about Earth’s moon, including information about its origin, phases, eclipses, and how it shines.

What Are Moons?

Natural or artificial bodies that revolve around larger bodies such as planets are called **satellites**. Except for Mercury and Venus, all of the planets have natural satellites, called moons. Moons come in a wide variety of sizes, shapes, and compositions.

What Do We Know About Earth’s Moon?

Scientists have learned a lot about Earth’s moon, which is also called *Luna*. Much of what we know comes from observations from Earth, but recent discoveries have come from visiting the moon. Some lunar rocks brought back by Apollo astronauts were studied and found to be almost 4.6 billion years old. These rocks have not changed much since they were formed. This tells scientists that the solar system itself is at least 4.6 billion years old. ✓

READING CHECK

1. Explain How do scientists know what the moon’s crust is made of?

THE MOON’S SURFACE

The moon’s surface is almost as old as Earth. It is covered with craters, many of which can be seen from Earth on a clear night. Because the moon has no atmosphere and no erosion, its surface shows where objects have collided with it. Scientists think that many of these collisions happened about 3.8 billion years ago. They were caused by matter left over from the formation of the solar system.

TAKE A LOOK

2. Identify What are the circular features on the moon’s face, and how did they form?

This image of Earth’s moon was taken by the *Galileo* spacecraft while on its way to Jupiter. The large, dark areas are lava plains called *maria*.



SECTION 4 Moons *continued***THE ORIGIN OF THE MOON**

When scientists studied the rock samples brought back from the moon by astronauts, they found some surprises. The composition of the moon is similar to that of Earth's mantle. This evidence has led to a new theory about the moon's formation. ✓

Scientists have created a new theory to explain what they now know. As shown in the figure below, they now think that there was a collision between Earth and another object about the size of Mars. This collision occurred while Earth was still forming. It was so violent that a large mass of material was thrown into orbit around Earth.

Gravity pulled this material into a sphere. The sphere continued to revolve around the planet. We now know it as the moon.

Moon Statistics

Distance from Earth	384,000 km
Period of rotation	27 days, 7 h
Period of revolution	27 days, 7 h
Diameter	3,475 km
Density	3.34 g/cm ³
Surface gravity	16% of Earth's

Formation of the Moon

1 Impact About 4.45 billion years ago, a body the size of Mars collided with the still molten Earth.

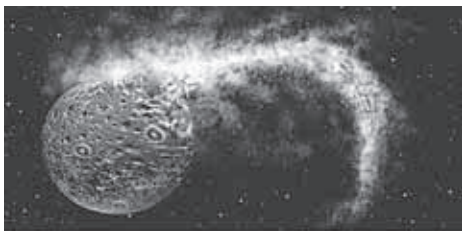

2 Ejection The debris from the collision, much of it from Earth's mantle, began to revolve around Earth.



3 Formation The clumps of material pulled together to form the moon.

READING CHECK

3. Identify What discovery caused scientists to revise their theory about the origin of the moon?

TAKE A LOOK

4. Identify According to this theory, material was thrown from Earth in clumps. What caused the material to come together as a sphere?

SECTION 4 Moons *continued*

CALIFORNIA STANDARDS CHECK

8.4.d Students know that stars are the source for all bright objects in outer space and that the Moon and the planets shine by reflected sunlight, not their own light.

5. Compare The moon does not produce its own light. How can the moon be seen from Earth?

READING CHECK

6. Explain What causes the moon to have a different appearance during a month?

MOONLIGHT

Unlike the sun, the moon does not generate its own energy in the form of light. The moon and all the planets shine because they reflect light from the sun. The total amount of sunlight that reaches the moon is always the same. The amount that is reflected to Earth varies.

PHASES OF THE MOON

Half the moon is always in sunlight. However, because the moon revolves around Earth, we cannot always see all of the part that is reflecting light. The moon revolves around the Earth once each month. It is interesting that it also rotates on its axis in exactly the same period. That's why we always see the same side of the moon.

During the month, the face of the moon that we can see changes from a fully lit circle to a thin crescent and then back to a circle. As the moon changes its position in relation to the sun and Earth, it has a different appearance. The figure below shows how the moon's appearance changes as it moves around Earth. ✓

The different appearances of the moon are called **phases**. When the moon is *waxing*, the amount of sunlight reflected off the moon and toward Earth increases every day. The moon appears to get bigger. When the moon is *waning*, the proportion of the sunlit side that we can see decreases every day. The moon appears to get smaller.

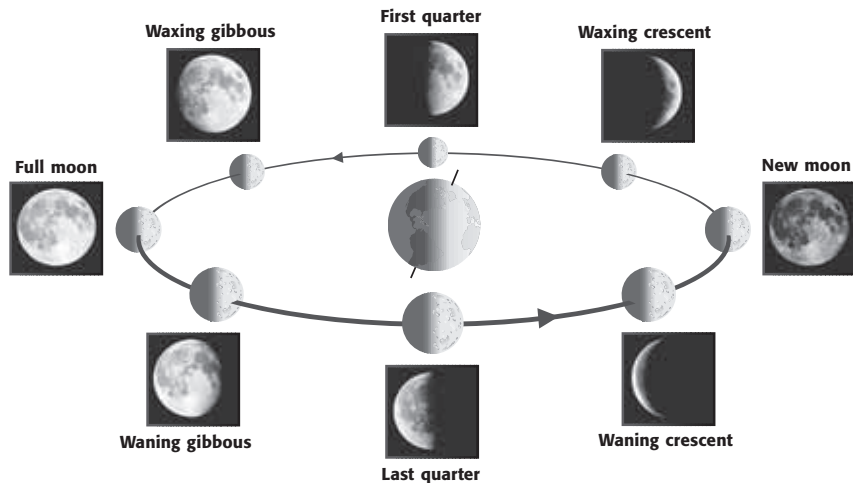

TAKE A LOOK

7. Identify In the figure, where is the sunlight coming from?

The positions of the moon, sun, and Earth determine which phase the moon is in. The photo inserts show how the moon looks from Earth at each phase.

SECTION 4 Moons *continued*

What Is an Eclipse?

An **eclipse** occurs when the shadow of one celestial body falls on another. A *solar eclipse* happens when the moon comes between the sun and Earth. Then the shadow of the moon falls on part of Earth’s surface. A *lunar eclipse* happens when Earth comes between the sun and the moon. Then the shadow of Earth falls on the moon. ✓

SOLAR ECLIPSES

Because the moon’s orbit is elliptical, or oval, instead of circular, the distance between Earth and the moon changes. When the moon is close to Earth in its orbit, the moon appears to be exactly the same size as the sun.

If the moon passes between the sun and Earth during that part of its orbit, there is a *total solar eclipse*, as shown in the figure below. If the moon is farther from earth, the eclipse is an *annular eclipse*. A thin ring of the sun can be seen around the moon.

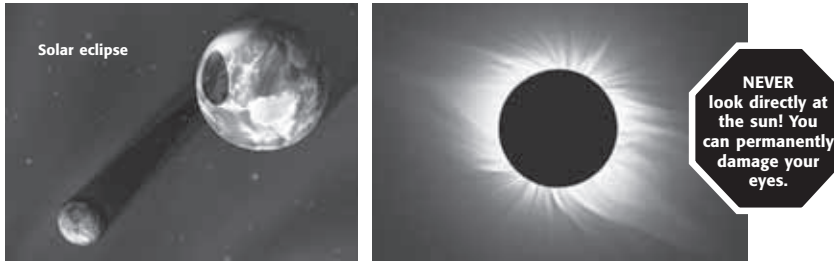

On the left is a diagram of the positions of Earth and the moon during a solar eclipse. On the right is a picture of the sun’s outer atmosphere, or *corona*, which is visible only when the entire disk of the sun is blocked by the moon.

THE MOON’S TILTED ORBIT

The moon rotates around Earth each month, so you might expect that there would be a solar eclipse each month. In reality, total solar eclipses occur only about once a year.

Solar eclipses don’t occur monthly because the moon’s orbit is slightly tilted in relation to Earth’s orbit around the sun. Earth must be in the moon’s shadow for there to be a solar eclipse. The moon’s tilt places Earth out of the moon’s shadow for most new moons. So, a solar eclipse is not seen monthly. ✓

READING CHECK

8. Explain What is the arrangement of the position of the sun, the moon, and Earth during a solar eclipse?

TAKE A LOOK

9. Explain Why can a solar eclipse not be seen from every point on Earth?

READING CHECK

10. Explain Why don’t solar eclipses occur each month?

SECTION 4 Moons *continued***LUNAR ECLIPSES**

A lunar eclipse occurs during a full moon when the moon passes through the shadow of Earth. Like solar eclipses, lunar eclipses do not occur each month. Unlike a solar eclipse, however, a lunar eclipse can be seen from much of the night side of the planet. The right-hand side of the figure below shows the position of Earth and the moon during a lunar eclipse.

Lunar eclipses are interesting to watch. At the beginning and end of a lunar eclipse, the moon is in the outer part of the shadow. In this part of the shadow, Earth's atmosphere filters out some of the blue light. As a result, the light that is reflected from the moon is red.

 **Say It**

Discuss In a group, discuss why you can't look at the sun during a solar eclipse but you can look at the moon during a lunar eclipse.

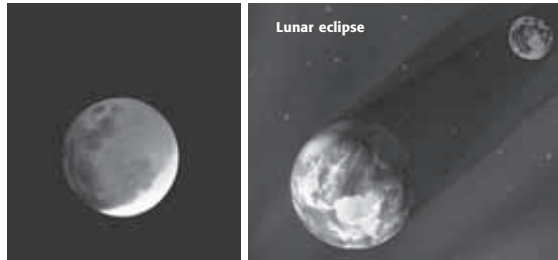

As the moon moves into Earth's shadow, the lower part is still in sunlight.

This is the position of Earth and the moon during a lunar eclipse.

Are Other Moons Like Earth's Moon?

All of the planets, except Mercury and Venus, have moons. Pluto has three known moons and Mars has two. All of the gas giants have many moons, some of which were discovered fairly recently, using spacecraft cameras or the Hubble Space Telescope. Some moons may not have been discovered yet. ✓

The solar system's moons vary widely. Moons range in size from very small bits of rock to objects as large as a terrestrial planet. Their orbits range from nearly circular to very elliptical. Most moons orbit in the same direction as the planets orbit the sun (prograde rotation). However, some orbit in the opposite direction (retrograde rotation).

THE MOONS OF MARS

Mars has two moons, Phobos and Deimos. They are small, oddly shaped satellites. Both moons have dark surfaces and resemble *asteroids*, rocky bodies in space. Phobos is about 22 km across at its largest dimension and Deimos is about 15 km across. Both moons may be asteroids that were captured by the gravity of Mars. ✓

 **READING CHECK**

11. Compare Which types of planets tend to have the most moons, terrestrial or gas giant?

 **READING CHECK**

12. Identify What are the names of Mars's moons?

SECTION 4 Moons *continued*

THE MOONS OF JUPITER

Jupiter has more than 60 moons. The four largest were discovered in 1610 by Galileo. When he observed Jupiter through a telescope, Galileo saw what looked like four dim stars that moved with Jupiter. He observed that they changed position relative to Jupiter and each other from night to night.

These moons, Ganymede, Callisto, Io, and Europa, are known as the *Galilean moons*. They appear small compared to the giant planet, as shown in the figure below. Actually, Ganymede, with a diameter of 5300 km, is larger than Mercury. Jupiter’s smaller moons range from 1 km to 250 km across. ✓

Io, the Galilean satellite closest to Jupiter, is covered with active volcanoes. There are at least 100 active volcanoes on its surface. Many of Io’s craters are covered by material from eruptions.

Evidence suggests that liquid water may lay below the icy surface of Europa. This discovery would make Europa one of the few bodies in the solar system, other than Earth, to have an ocean. ✓

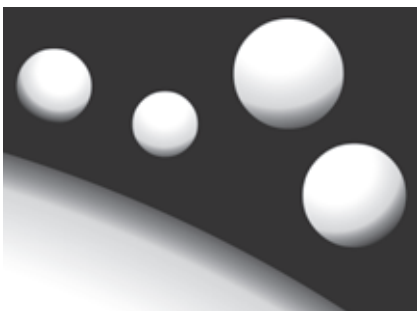

Relative sizes of Jupiter and its four largest satellites, Io, Europa, Ganymede, and Callisto. The distance is not shown to scale.

THE MOONS OF SATURN

Saturn has more than 50 moons. Saturn’s largest moon, Titan, is slightly smaller than Jupiter’s Ganymede. It is the only satellite in the solar system that has a sizable atmosphere. Titan’s atmosphere is composed mostly of nitrogen with small amounts of other gases like methane. Its atmosphere is denser than Earth’s atmosphere.

None of Saturn’s other moons are as large as the Galilean moons of Jupiter. Most of them are from several kilometers to several hundred kilometers across. They are composed of frozen water and rocks.

✓ **READING CHECK**

13. Identify What are the names of the Galilean moons?

✓ **READING CHECK**

14. Identify What may lie below the icy surface of Europa?

Critical Thinking

15. Make Inferences Would humans be able to live unprotected on the surface of Titan? Explain.

SECTION 4 Moons *continued*

THE MOONS OF URANUS

Uranus has at least 27 moons, most of which are small. They were discovered by space probes or orbiting observatories, such as the Hubble Space Telescope. Like the moons of Saturn, the largest moons of Uranus are made of ice and rock. Many of its smaller moons were objects traveling in space that may have been captured by Uranus’s gravity. ✓

 **READING CHECK**

16. Explain How did Uranus get many of its smaller moons?

THE MOONS OF NEPTUNE

Neptune has 13 known moons. The largest, Triton, revolves in a retrograde orbit. This suggests that Triton was captured by Neptune’s gravity after forming somewhere else in the solar system. Triton has a thin nitrogen atmosphere. Its surface is mostly frozen nitrogen and methane. Triton has active “ice volcanoes” that send nitrogen high into its atmosphere. Neptune’s other moons are small objects made of ice and rock.

THE MOONS OF PLUTO

Pluto has three moons. The diameter of Charon is about half that of Pluto. Charon revolves around Pluto in 6.4 days, the same period as Pluto’s rotation. That means that Charon is always located at the same place in Pluto’s sky. Two additional moons of Pluto, discovered by the Hubble telescope in 2005, are much smaller than Charon.

Some of the Moons of the Solar System

Planet	Moon	Diameter (km)	Period of revolution (days)
Earth	Luna	3,475	27.3
Mars	Phobos	26	0.3
Mars	Deimos	15	1.3
Jupiter	Io	3,636	1.8
Jupiter	Europa	3,120	3.6
Jupiter	Ganymede	5,270	7.1
Jupiter	Callisto	4,820	16.7
Saturn	Titan	5,150	15.9
Uranus	Titania	1,580	8.7
Neptune	Triton	2,700	5.9
Pluto	Charon	1,180	6.4

 **CALIFORNIA STANDARDS CHECK**

8.4.e Know the appearance, general composition, relative position and size, and motion of objects in the solar system, including planets, planetary satellites, comets, and asteroids.

17. Identify Relationships

Some of the moons of the gas giants are larger than Mercury. Why are they not considered to be planets?

Section 4 Review

8.2.g, 8.4.d, 8.4.e



SECTION VOCABULARY

eclipse an event in which the shadow of one celestial body falls on another

phase the change in the sunlit area of one celestial body as seen from another celestial body

satellite a natural or artificial body that revolves around a planet

1. Identify During which phase of the moon can a lunar eclipse occur?

2. Identify Fill in the blanks to complete the chart.

An object that revolves around a planet is called a

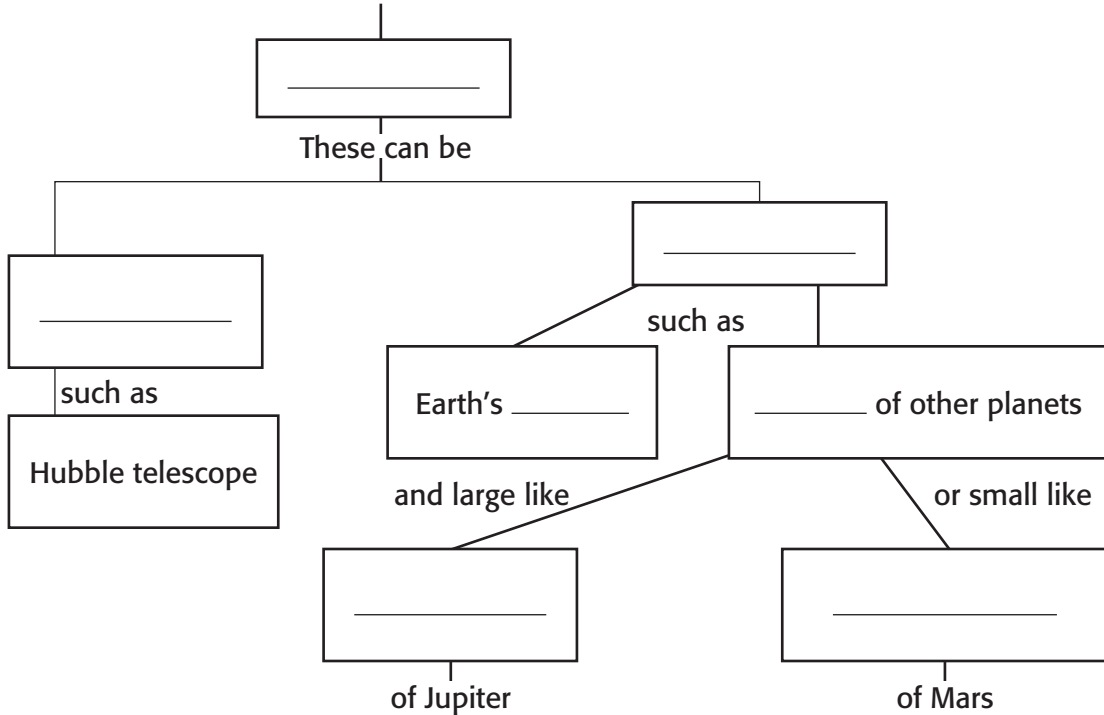

3. Analyze Methods How can astronomers use rocks from the moon to estimate the age of the solar system?

4. Analyze Concepts Does the mass of a planet seem to affect how many moons it has? Explain your answer.

SECTION 5 **Small Bodies in the Solar System**



8.4.e

BEFORE YOU READ

After you read this section, you should be able to answer these questions:

- What are comets and what are they made of?
- What are asteroids and where are they found?
- What is a meteoroid?



Organize In your notebook, create a Comparison Table that compares comets, asteroids, and meteoroids.

What Is in Our Solar System?

The sun, the planets, and their moons are not the only objects in our solar system. There are also many smaller bodies, including comets, asteroids, and meteoroids. Scientists study these objects to learn about the formation and composition of the solar system.

What Are Comets?

A **comet** is a small, loosely packed body of ice, rock, and dust. The core, or nucleus, of a comet is made of rock, metals, and ice. A comet's nucleus can range from 1 km to 100 km in diameter. A spherical cloud of gas and dust, called a *coma*, surrounds the nucleus. The coma may extend as far as 1 million km from the nucleus. ✓



1. Describe What is a comet made of?

COMET TAILS

A comet's tail is its most spectacular feature. Sunlight changes some of the comet's ice to gas, which streams away from the nucleus. Part of the tail is made of *ions*, or charged particles. The ion tail, pushed by the solar wind, always moves away from the sun, no matter which way the comet is moving. A second tail, made of dust, follows the comet in its orbit. Some comet tails are more than 80 million km long, glowing brightly with reflected sunlight.

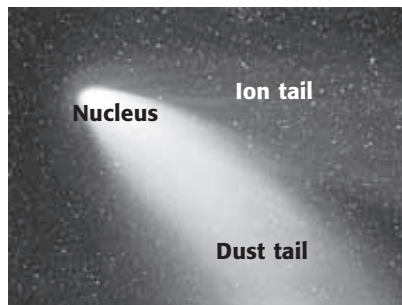

This image shows the physical features of a comet when the comet comes close to the sun. The nucleus of a comet is hidden by the brightly lit gases and dust.

TAKE A LOOK

2. Identify Draw an arrow from the "Nucleus" label to show the direction the comet is moving.

SECTION 5 Small Bodies in the Solar System *continued*

ORIGINS OF COMETS

Scientists think that many comets come from the Oort cloud. The *Oort cloud* is a spherical cloud of dust and ice. It surrounds the solar system far beyond the orbit of Pluto. Comets may be attracted by the gravity of nearby stars. This may cause them to fall into an elliptical orbit around the sun, as shown in the figure below. Other comets are found in the *Kuiper belt*, a flat ring of objects just beyond Neptune’s orbit. ✓

Scientists think that comets are made of matter that was left over when the solar system formed. They would like to learn more about comets to better understand the solar system’s history. Several spacecraft have been launched to gather comet dust. In 2004, the spacecraft Stardust collected material from a comet named Wild 2.

READING CHECK

3. Identify Where is the Oort cloud located?

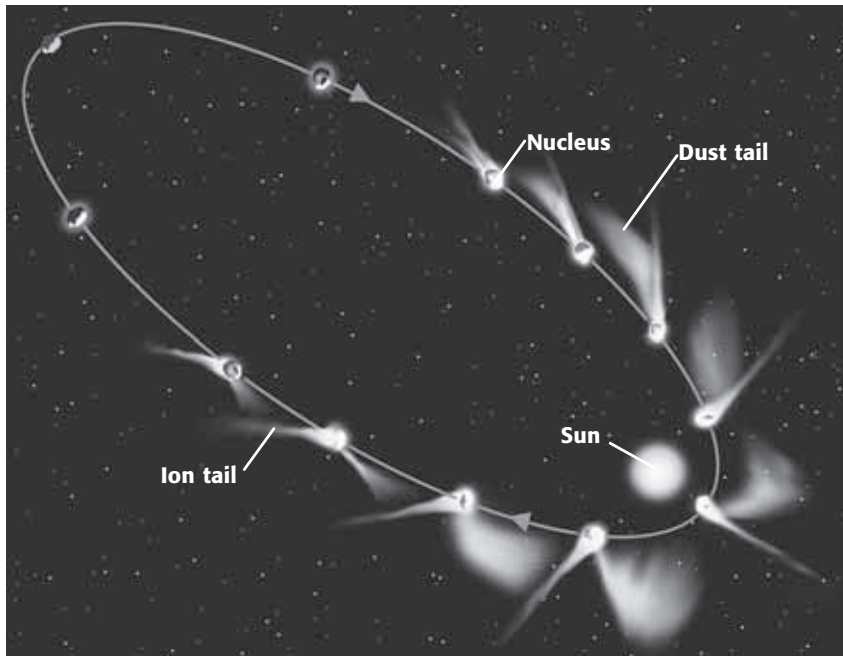

Comets have very long orbits that take them close to the sun and well beyond Pluto.

LONG- AND SHORT-PERIOD COMETS

Comets in orbit come close to the sun over and over again. Many of their orbital periods have been calculated and some have been observed several times. If a comet takes more than 200 years to complete one orbit, it is called a long-period comet. Other comets, mostly from the Kuiper belt, take less than 200 years. The famous Halley’s comet is a short-period comet, returning every 76 years.

TAKE A LOOK

4. Explain Why does the ion tail extend in different directions during most of the comet’s orbit?

Critical Thinking

5. Describe Events Why can Halley’s comet be seen from Earth only for about 1 year of its 76-year orbit?

SECTION 5 Small Bodies in the Solar System *continued*

What Are Asteroids?

Small, rocky bodies that revolve around the sun are called **asteroids**. They range in size from a few meters to almost 1,000 km in diameter. More than 50,000 asteroids have been discovered. None of them can be seen from Earth without a telescope. In fact, they were not known to exist until 1801.

Most asteroids orbit the sun in the asteroid belt. This is a 300-million-km-wide region located between the orbits of Mars and Jupiter. Astronomers think that asteroids are made of material from the early solar system. The pull of Jupiter's gravity prevented this material from coming together to form a planet. ✓

READING CHECK

6. Identify Where is the asteroid belt located?

Critical Thinking

7. Make Inferences Why does Eros have an irregular shape instead of a spherical shape?



NASA's *NEAR* spacecraft landed on the asteroid Eros in 2001. This view of the cratered surface of Eros was taken from an altitude of 200 km.

COMPOSITION OF ASTEROIDS

It is hard to determine what asteroids are made of. This is because they are small and usually far away from Earth. Mostly, they are composed of either rock or metal. Some asteroids may contain carbon and carbon compounds.

In general, asteroids do not have a spherical shape because of their small size. Gravity must be very large to pull matter together into a spherical shape. The table below gives several facts about selected asteroids.

Some Asteroid Facts

Asteroid	Date discovered	Size or diameter (km)	Interesting fact
Ceres	1801	960 × 940	largest known
Pallas	1802	570 × 525 × 482	second largest
Vesta	1807	530	brightest
Ida	1884	58 × 23	has a satellite asteroid
Eros	1898	33 × 13 × 13	first near-Earth asteroid discovered
Ganymede	1924	32	largest near-Earth asteroid

TAKE A LOOK

8. Compare How do asteroid sizes compare with planet sizes?

SECTION 5 Small Bodies in the Solar System *continued***NEAR-EARTH ASTEROIDS**

More than 1,000 asteroids have wide, elliptical orbits that bring them close to Earth. They are called near-earth asteroids. Scientists are interested in these asteroids because they can cause great damage if they strike Earth. The Barringer meteorite crater is shown in the figure below. It was made when an asteroid struck Earth about 40,000 years ago. The asteroid was less than 50 m in diameter, but it caused a crater 1,200 m across!

Asteroid detection programs now identify and track asteroids whose orbit may bring them close to the planet. Scientists hope to be able to prevent future collisions by identifying asteroids that could be a problem in the future.



Barringer Crater in northern Arizona has a diameter of 1,200 m.

TAKE A LOOK

9. Identify What struck Earth to form this crater?

What Are Meteoroids?

Pieces of dust and debris from asteroids and comets, called **meteoroids**, are scattered throughout the solar system. Most meteoroids are about the size of a grain of sand. When a meteoroid enters Earth's atmosphere, it can reach a speed between 35,000 and 250,000 km/h.

Friction with the atmosphere heats meteoroids and the air around them to thousands of degrees, causing a bright glow. The glowing trails that form when meteoroids burn up in the atmosphere are called **meteors**. A meteor trail can be a few hundred meters in diameter and tens of kilometers long before it fades.

Every few days, a larger meteoroid enters the atmosphere. Some of these bodies pass through the atmosphere without burning up completely. The meteoroids that reach Earth's surface are called **meteorites**. ✓

✓ **READING CHECK**

10. Compare What is the difference between a meteoroid and a meteorite?

SECTION 5 Small Bodies in the Solar System *continued*

COMPOSITION OF METEORITES

Meteorites are classified as one of three types: stony, metallic, and stony-iron. Stony meteorites are similar to rocks on Earth. Some of them include carbon compounds similar to those found in living organisms. Metallic meteorites have a distinctive metallic appearance and do not look like terrestrial rocks. Stony-iron meteorites are made of rocky material, iron, and nickel. ✓

READING CHECK

11. List What are the three types of meteorites?

METEOR SHOWERS

Meteors can be seen on most clear nights. When many small meteoroids enter the atmosphere in a short period, it is called a *meteor shower*. During some meteor showers, several meteors are visible every minute. Meteor showers occur at the same time each year. These showers happen because Earth passes through orbits of comets that have left a dust trail.

Three Major Types of Meteorites

Stony Meteorite:
rocky material

Metallic Meteorite:
iron and nickel

Stony-iron Meteorite:
rocky material, iron,
and nickel



TAKE A LOOK

12. Identify What metals are found in a metallic meteorite?

IMPACTS ON EARTH

Most objects that enter Earth’s atmosphere are small and burn up completely before reaching the surface. However, scientists think that impacts powerful enough to cause a natural disaster happen every few thousand years. An impact large enough to cause a global catastrophe may occur once every 50 million to 100 million years.

About 65 million years ago, a meteor 10 km wide struck Earth. Massive amounts of debris from this impact entered the atmosphere. The debris may have left the planet in darkness for months and dropped temperatures to near freezing for years. The impact may have caused 15% to 20% of the species on Earth, including the dinosaurs, to become extinct.

Section 5 Review

SECTION VOCABULARY

<p>asteroid a small, rocky object that orbits the sun; most asteroids are located in a band between the orbits of Mars and Jupiter</p> <p>comet a small body of ice, rock, and cosmic dust that follows an elliptical orbit around the sun and that gives off gas and dust in the form of a tail as it passes close to the sun</p>	<p>meteor a bright streak of light that results when a meteoroid burns up in Earth's atmosphere</p> <p>meteorite a meteoroid that reaches Earth's surface without burning up completely</p> <p>meteoroid a relatively small, rocky body that travels through space</p>
--	---

1. Describe How can a comet become the source of meteoroids and meteors?

2. Classify Fill in the blanks to complete the table.

Object	Composition	Main location
	large chunks of rock or metal, much smaller than planets	
		Oort cloud and Kuiper belt
	small chunks of rock or metal	throughout the solar system

3. Evaluate Theories Why is information about comets, asteroids, and meteoroids important for understanding the development of the solar system?

4. Compare and Contrast How do the orbits of comets differ from the orbits of most asteroids?

5. Apply Concepts Why would scientists want to know if an asteroid is on a course to collide with Earth in 20 years?
